

ECOGLOSS

LENS CATALOGUE

ASPHERICAL LENSES

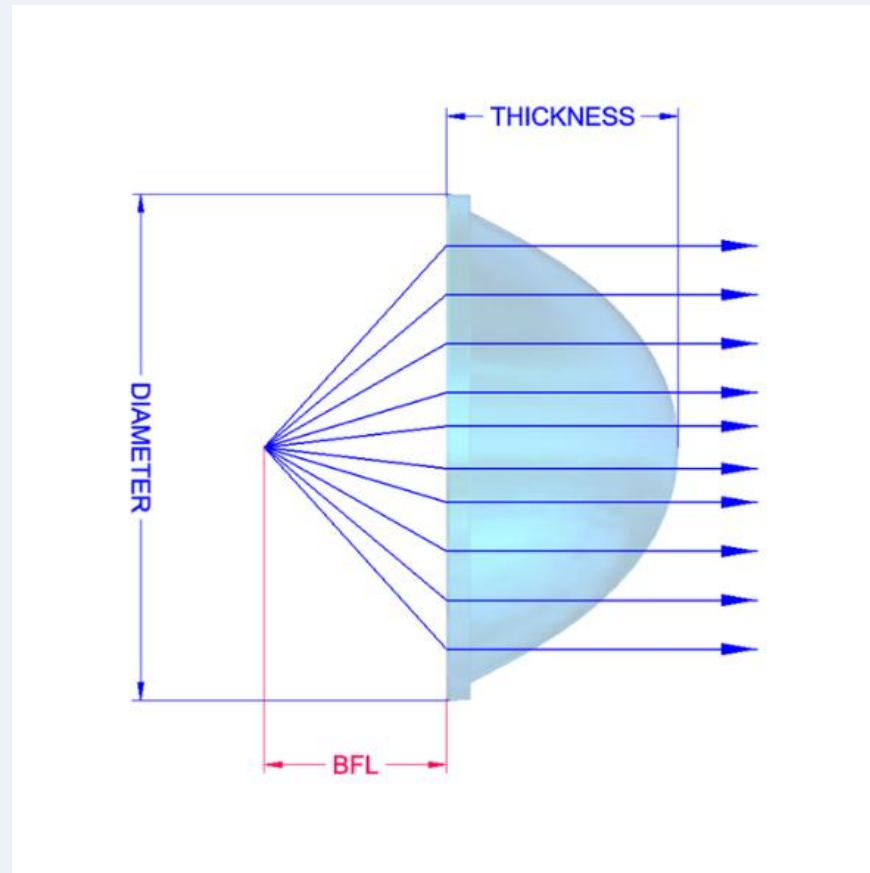

TIR LENSES

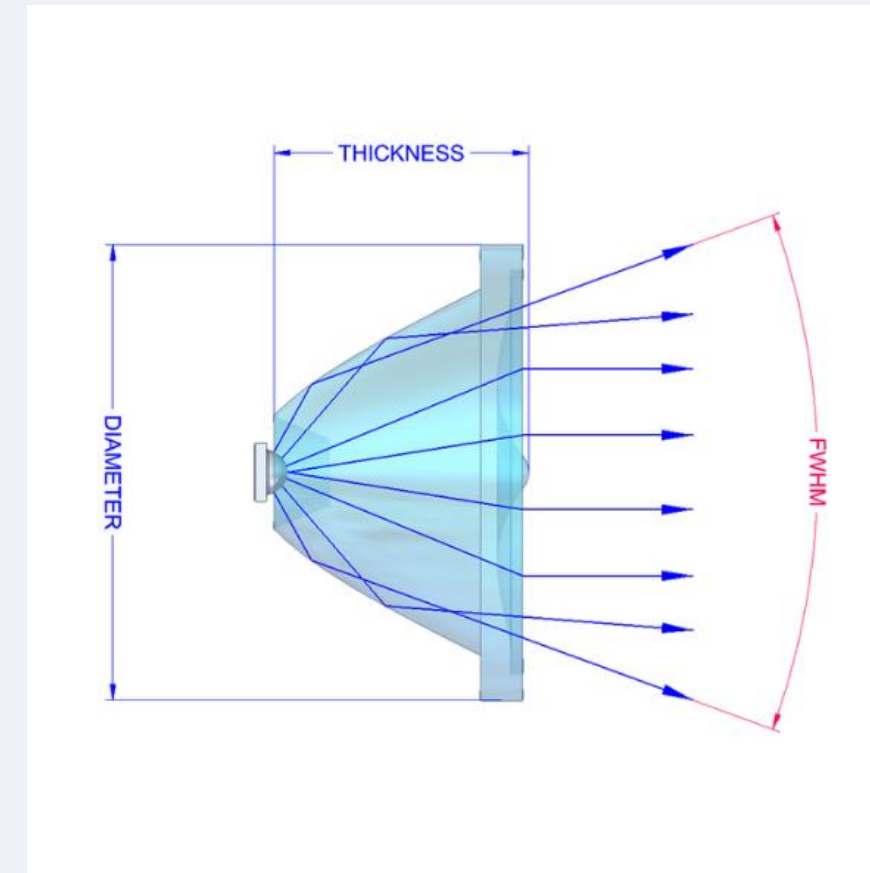

CAVITY LENSES

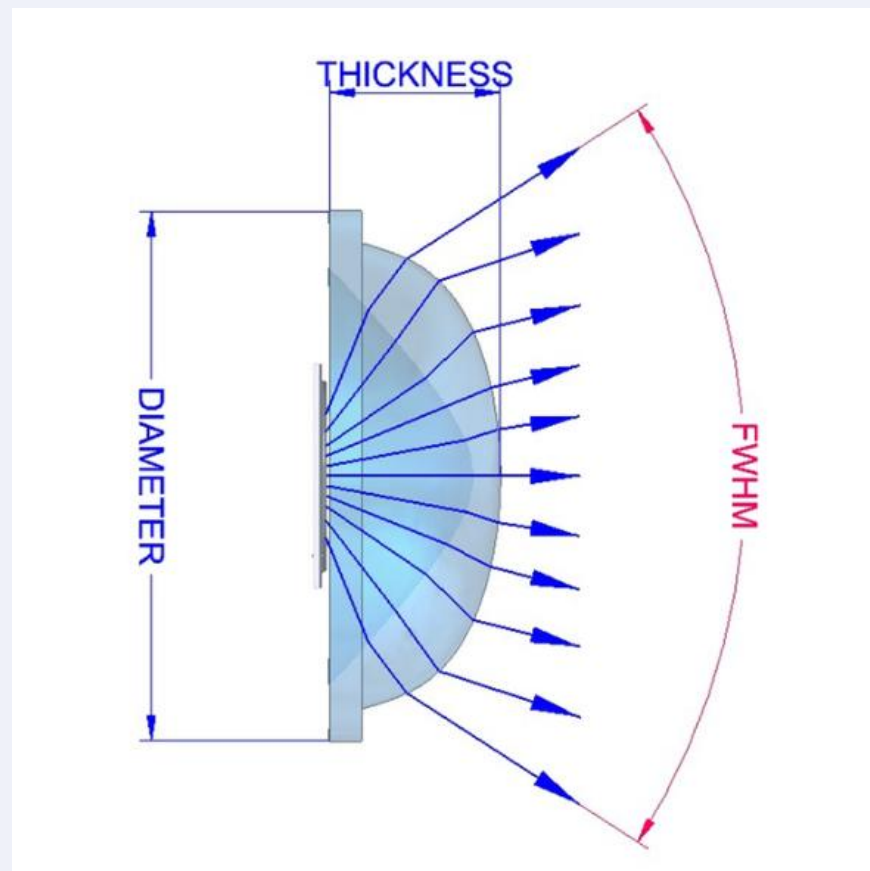

FRESNEL LENSES

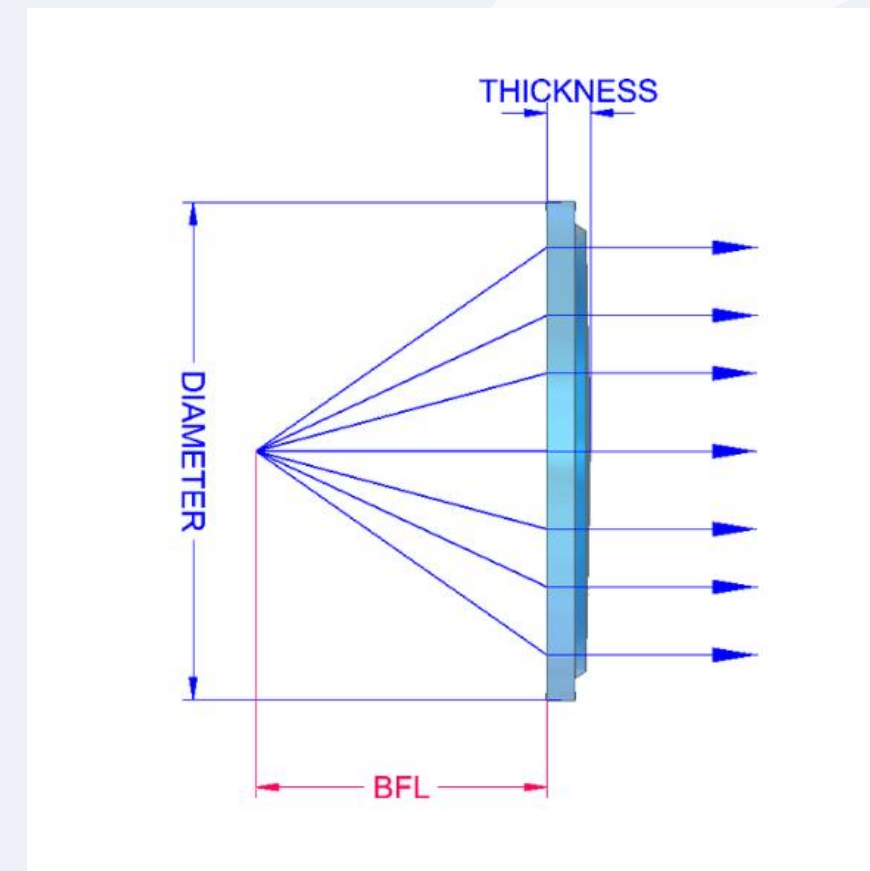

ECOGLOSS Aspherical Lenses

ECOGLOSS code	Lens type	BFL (mm)	Diameter (mm)	Thickness (mm)	ECOGLOSS code	Lens type	BFL (mm)	Diameter (mm)	Thickness (mm)
A003 7124	Plano-convex	41,5	71,0	23,8	A182 1506	Plano-convex	14,3	15,0	5,2
A010 6515	Plano-convex	67,3	65,0	14,5	A194 1506	Plano-convex	8,6	15,0	5,6
A011 4512	Plano-convex	35,3	45,0	12,0	A196 7120	Plano-convex	53,5	70,4	19,7
A016 4923	Plano-convex	21,1	49,0	23,0	A234 7733	Plano-convex	38,0	77,0	33,0
A019 5322	Plano-convex	25,0	53,0	21,26	A373 4508	Plano-convex	67,2	46,0	8,4
A034 1807	Plano-convex	10,4	18,0	6,7	A413 1206	Plano-convex	6,3	12,0	6,0
A053 1807	Plano-convex	8,4	18,0	7,4	A501 2207	Plano-convex	10,0	22,0	6,9
A068 6015	Plano-convex	53	59,8	15,0	A581 2808	Plano-convex	25,0	28,0	8,0
A071 5224	Plano-convex	18,6	51,8	23,7	A582 7522	Plano-convex	53,2	75,2	22,2
A079 6422	Plano-convex	41,6	64,0	21,5	A636 5422	Plano-convex	25,8	54,0	21,6
A104 6616	Plano-convex	66,5	66,0	14,9	A650 8034	Plano-convex FWHM (5° / 15°)	34,8	80,0	33,4
A116 7727	Plano-convex	45,1	77,0	27,2	A837 3515	Plano-convex	15,6	35,0	14,8
A132 6523	Plano-convex	38,6	65,0	22,5	A838 1605	Plano-convex	16,8	16,0	4,3
A163 6827	Plano-convex	40,0	68,0	26,0	A850 6315	Plano-convex frosted	67,0	62,8	14,5
A175 6419	Plano-convex	40,0	64,0	21,4	A904 4512	Plano-convex frosted	35,3	45,0	12,0
A180 6016	Plano-convex	67,0	60,0	15,2	A912 5225	Plano-convex frosted	18,6	51,9	25,2



A003 7124

REVISION HISTORY			
REV	DESCRIPTION	DATE	APPROVED

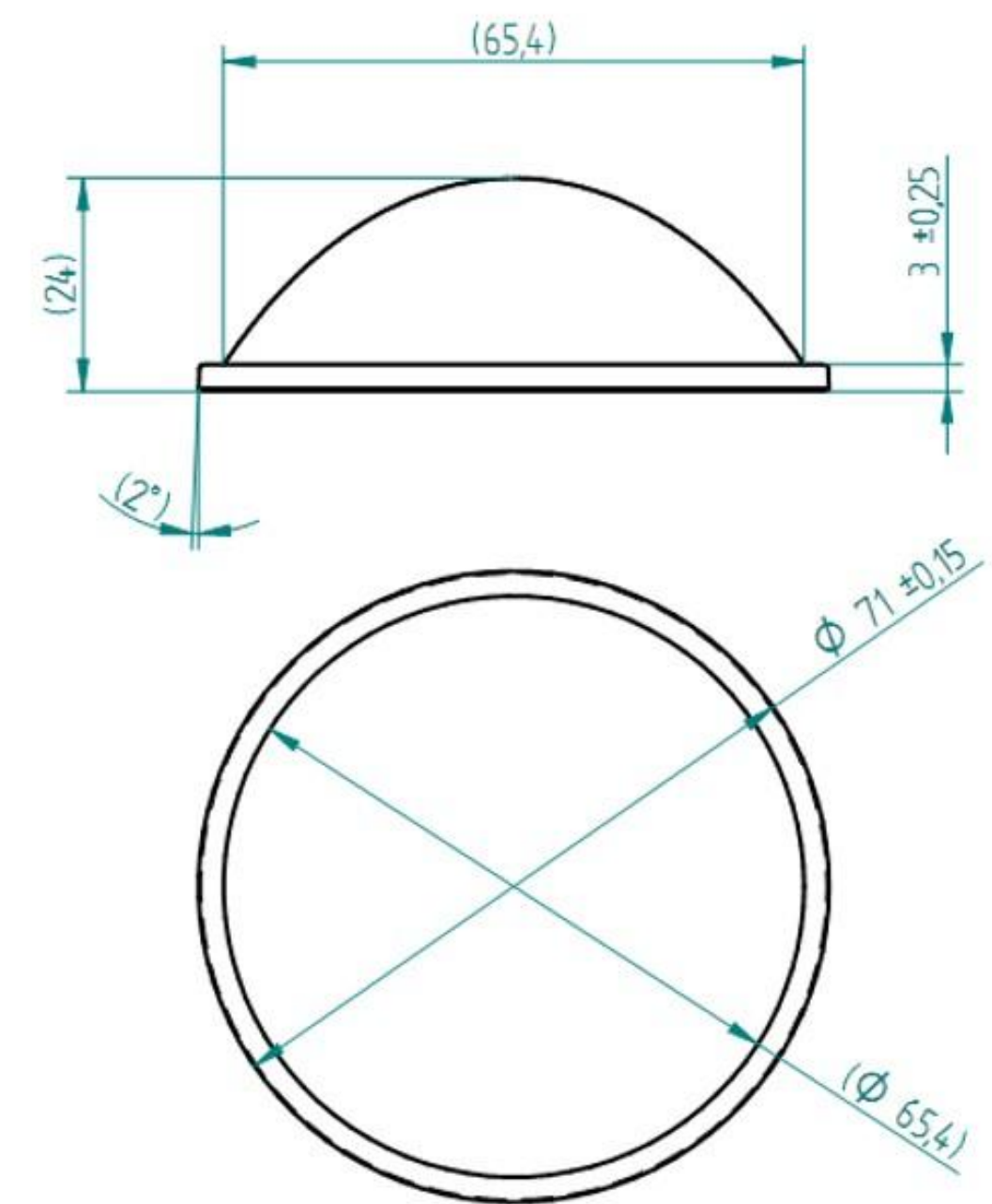

SCALE 1:2

Glass: LIBA or alternative (nd = 1,521)

	NAME	DATE	
DRAWN	krulsky	05/14/20	
CHECKED			
ENG APPR			
MER APPR			
UNLESS OTHERWISE SPECIFIED DIMENSIONS ARE IN MILLIMETERS			A003 7124 <small>FILE NAME: A003_small.tif</small> <small>SCALE: WEIGHT: 126 g SHEET 1 OF 1</small>

A003 7124 – simulation results

- Polar Candela Distribution Plot

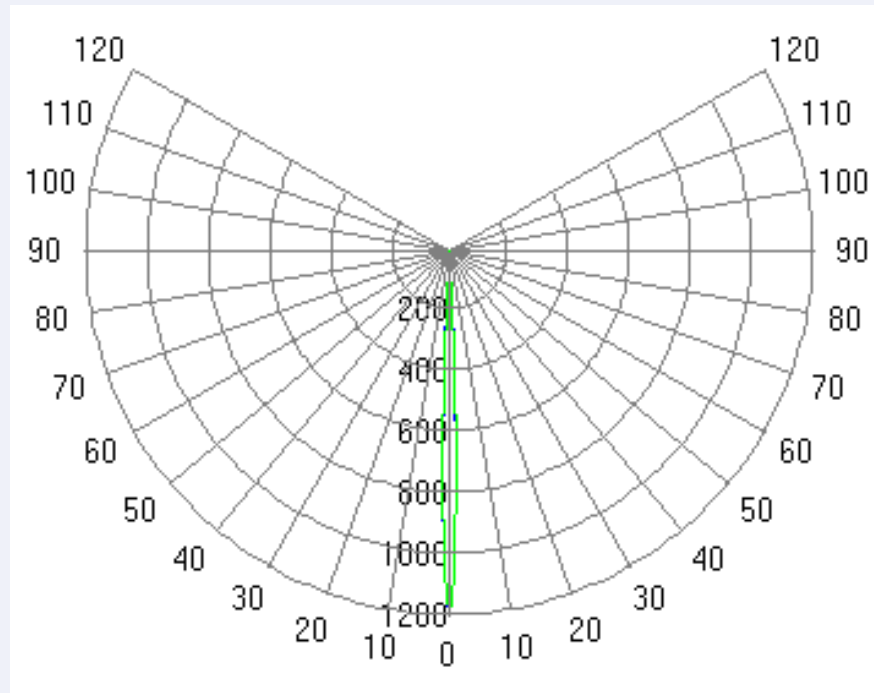

- Rectangular Candela Distribution Plot

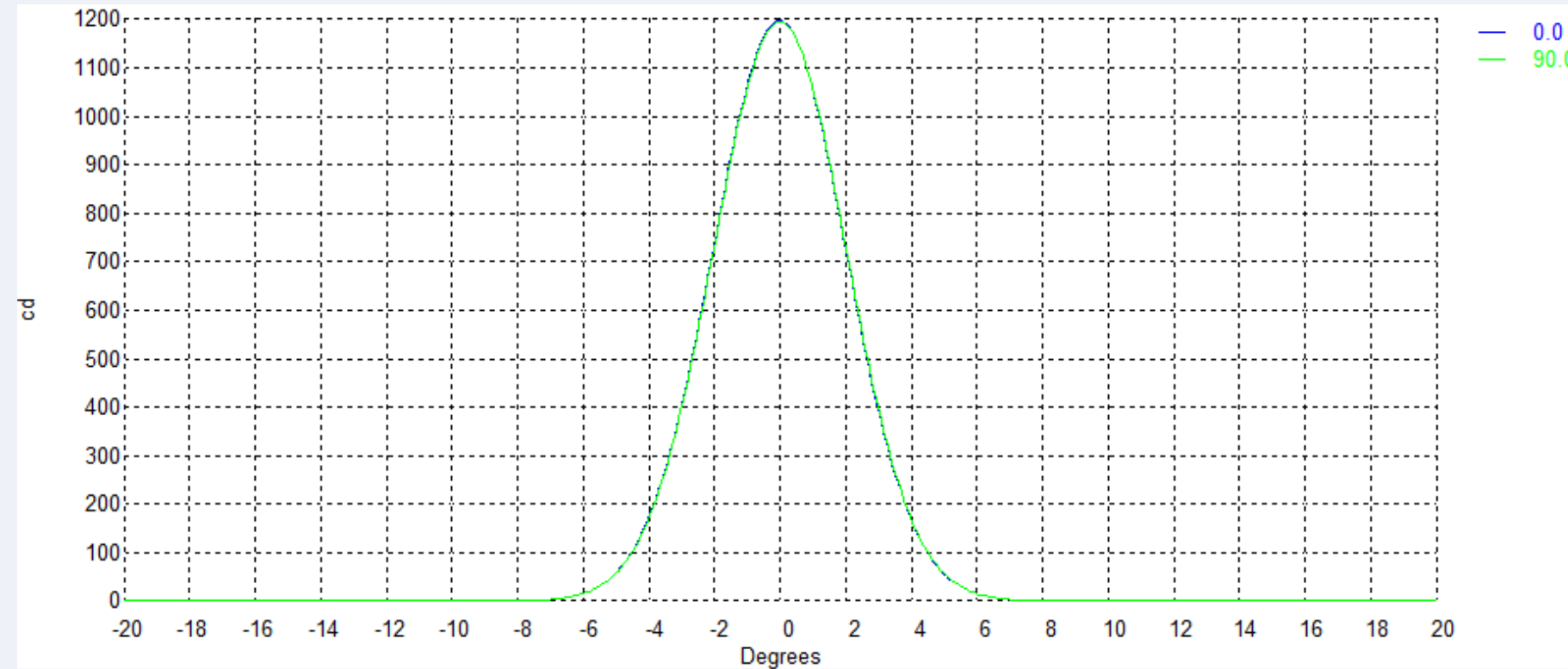

- Projection wall 3x3 m at 1m

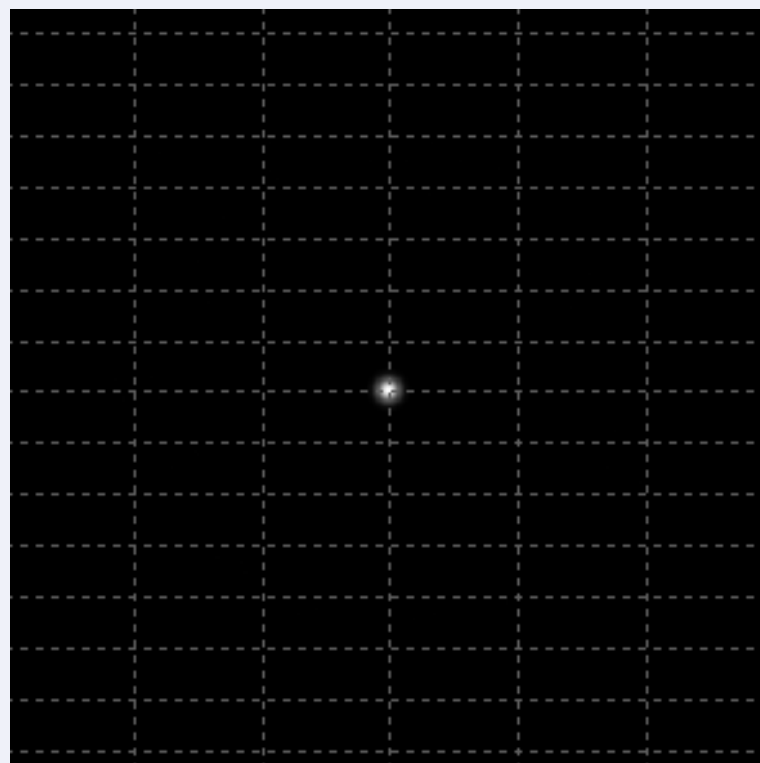

LED used for simulation	Cree XP-G
Luminous flux of LED [lm]	36
FWHM Co [°]	5
FWHM C90 [°]	5

* The ratio between luminous flux on the projection wall (3x3 m at 1 m) and luminous flux of LED

A010 6515

REVISION HISTORY			
REV.	DESCRIPTION	DATE	APPROVED

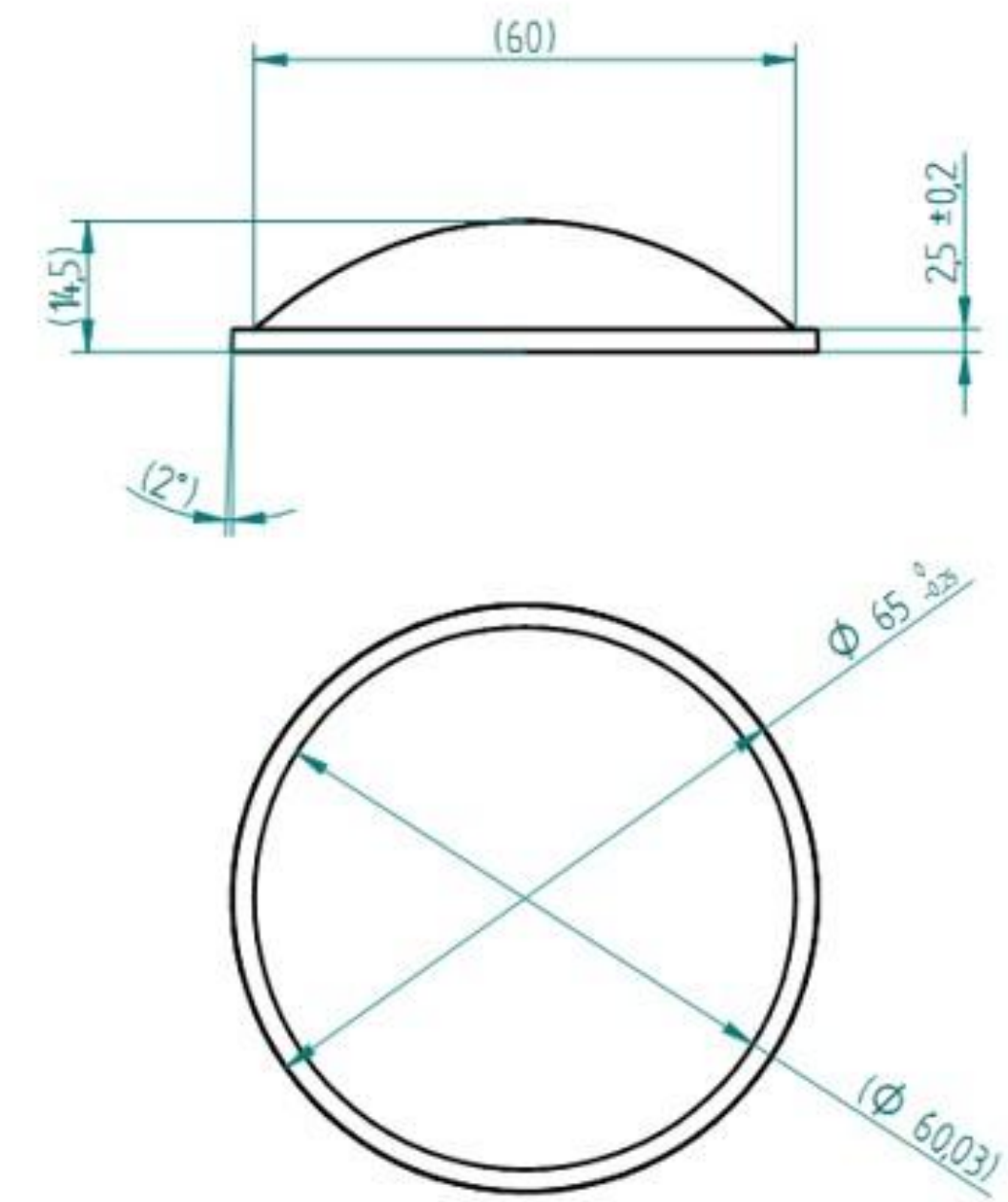

SCALE 1:2



Glass: LIBA or alternative (nd = 1,521)

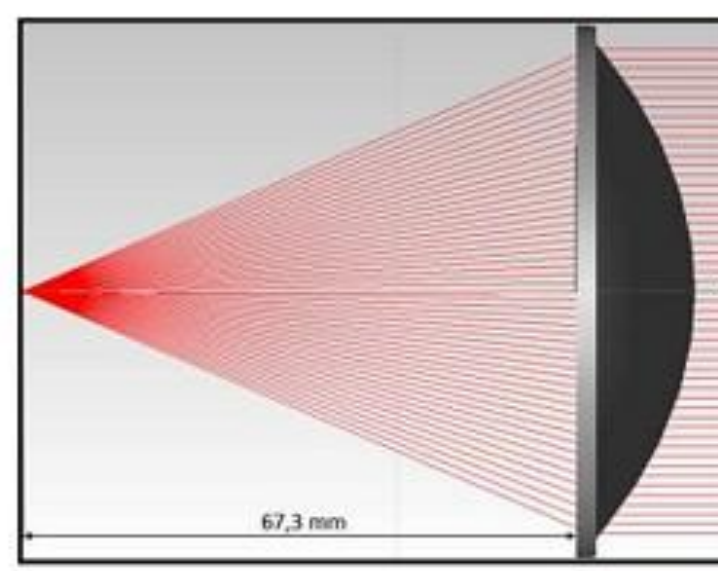

DRAW	NAME	DATE	 <p>ECOGLOSS</p> <p>A010 6515</p>
UNLESS OTHERWISE SPECIFIED DIMENSIONS ARE IN MILLIMETERS			SIZE: 44 FILE NAME: A010_enu1011 SCALE: WEIGHT: 66 g SHEET 1 OF 1

A010 6515 – simulation results

- Polar Candela Distribution Plot

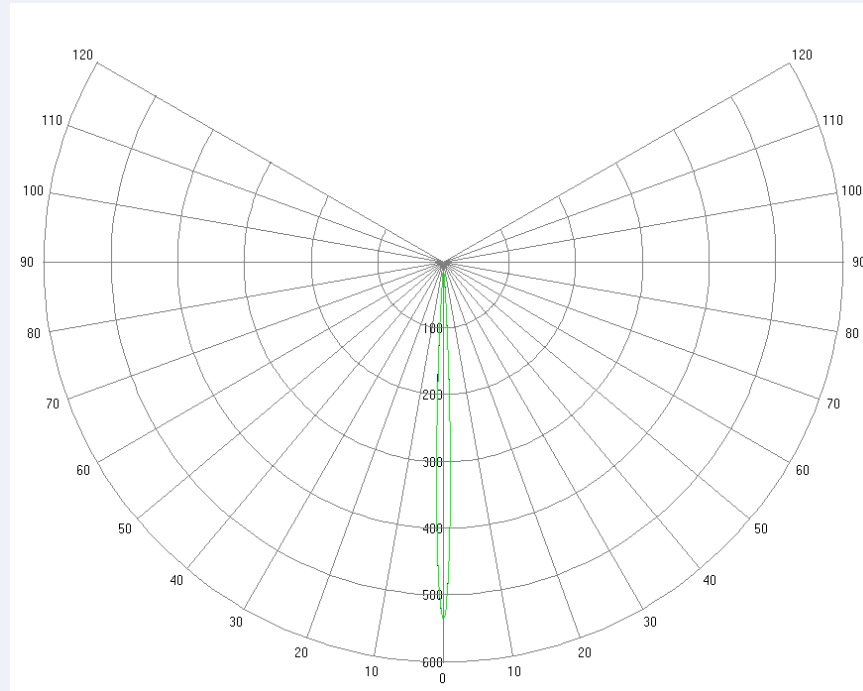

- Rectangular Candela Distribution Plot

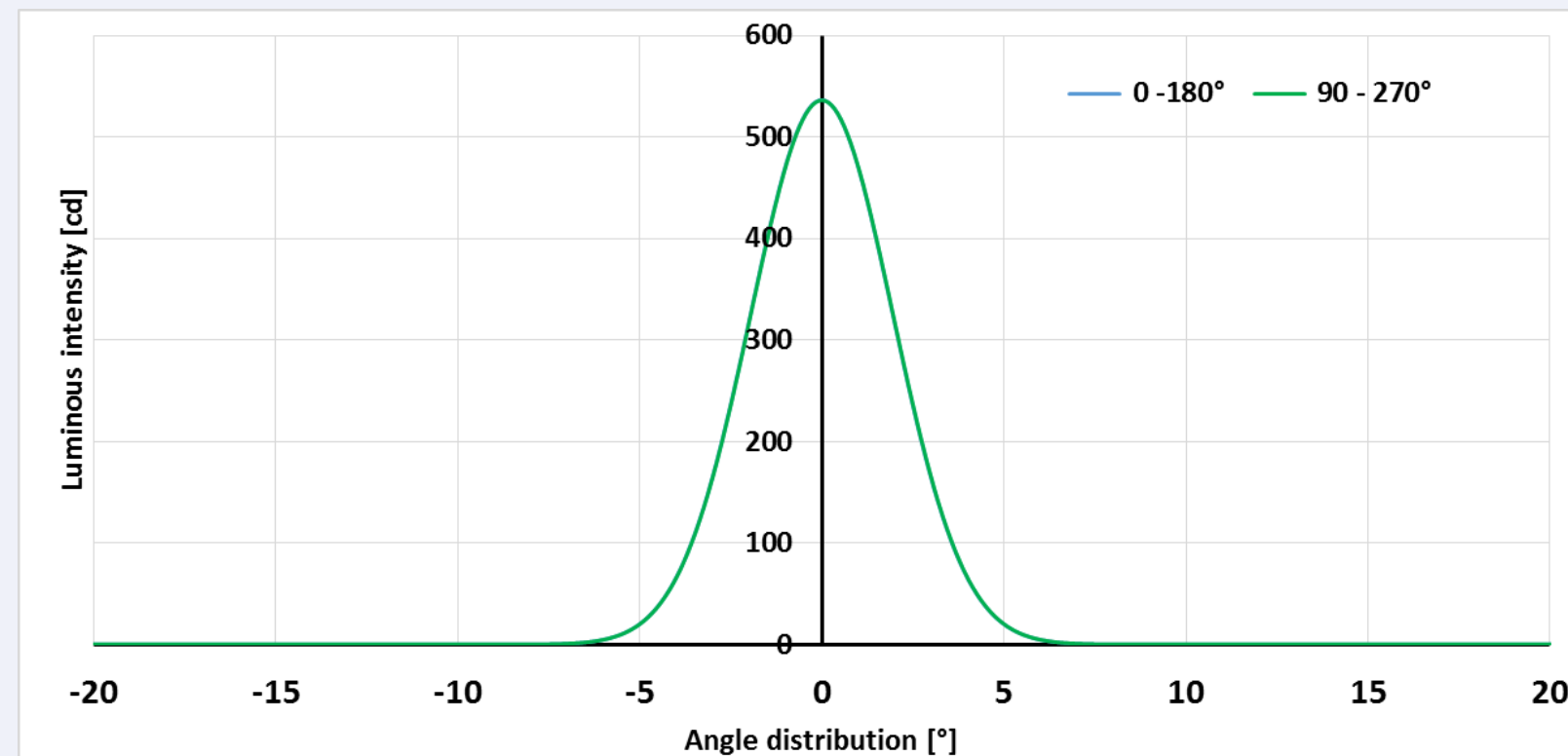

- Projection wall 3x3 m at 1m

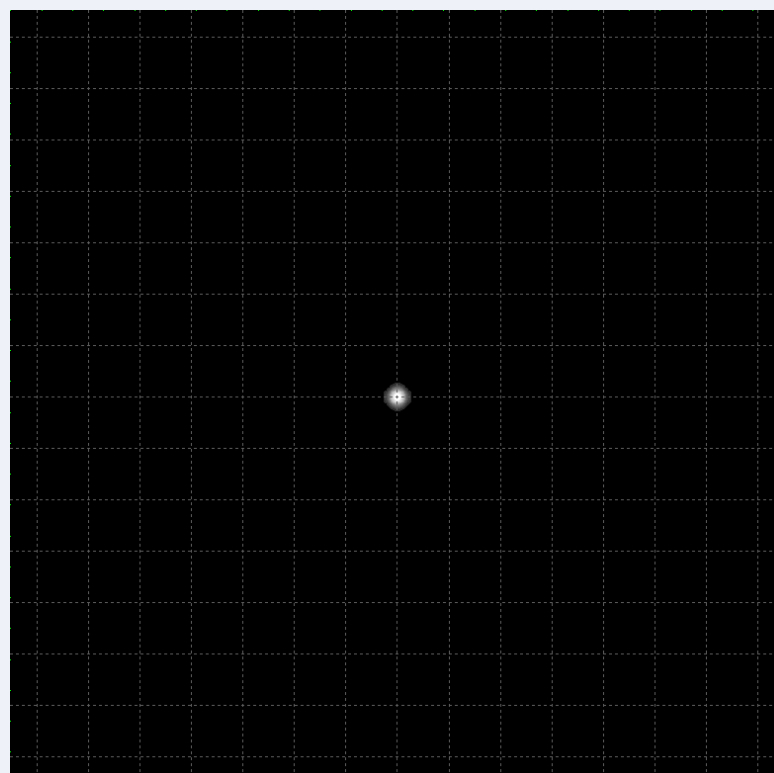

LED used for simulation	Cree XP-G
Luminous flux of LED [lm]	36
FWHM C ₀ [°]	6
FWHM C ₉₀ [°]	6

* The ratio between luminous flux on the projection wall (3x3 m at 1 m) and luminous flux of LED

A011 4512

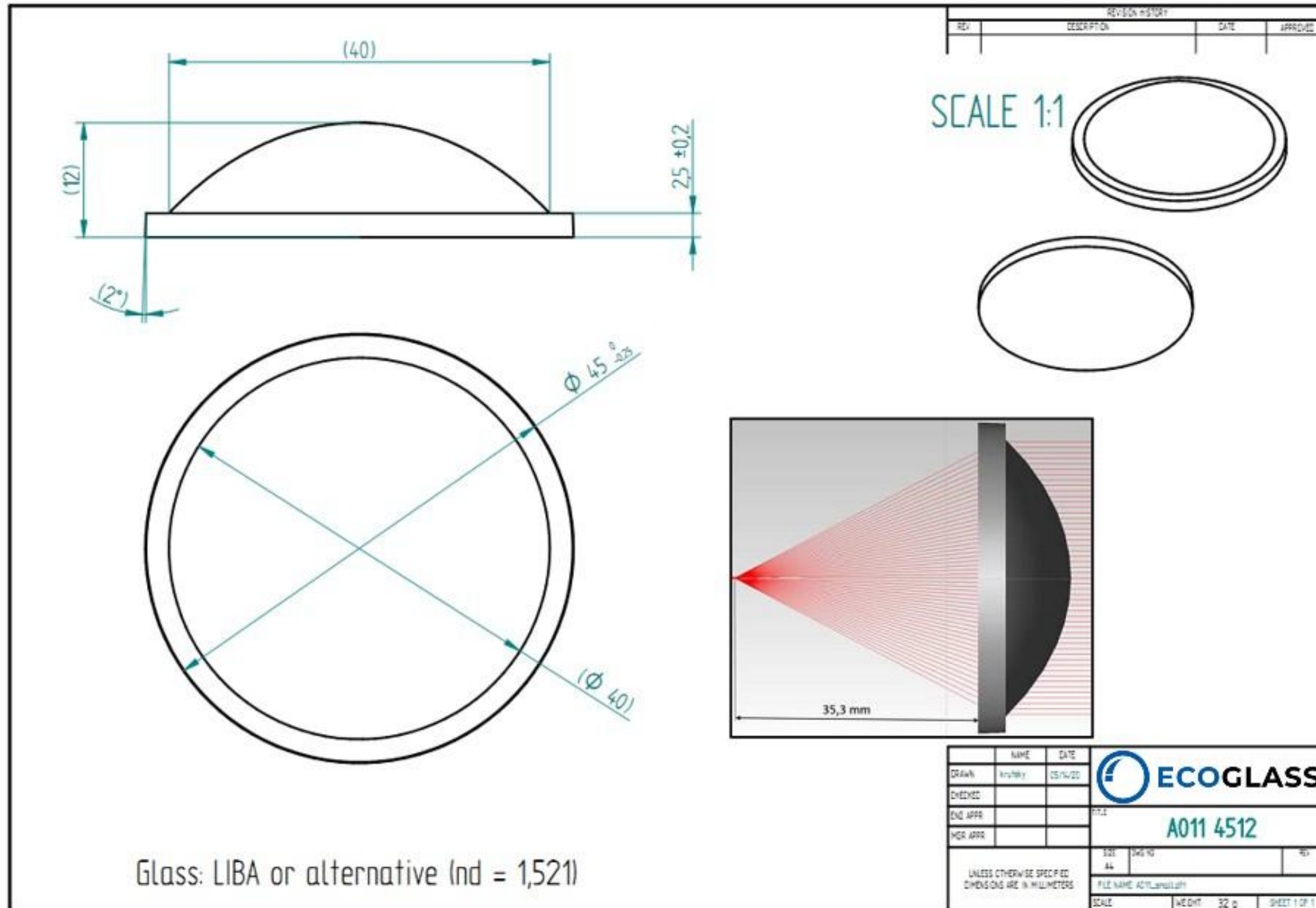

A011 4512 – simulation results

- Polar Candela Distribution Plot

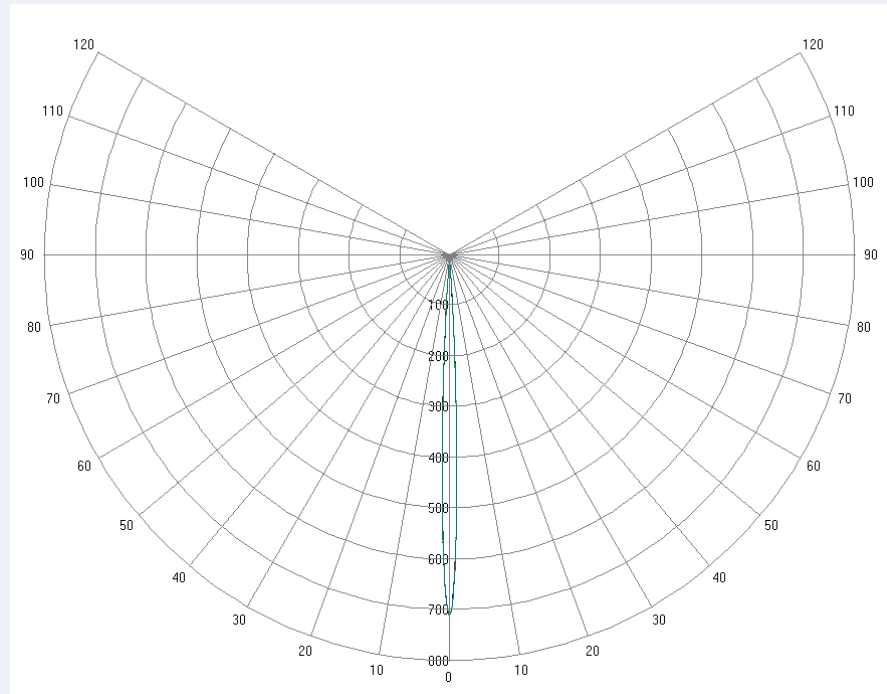

- Rectangular Candela Distribution Plot

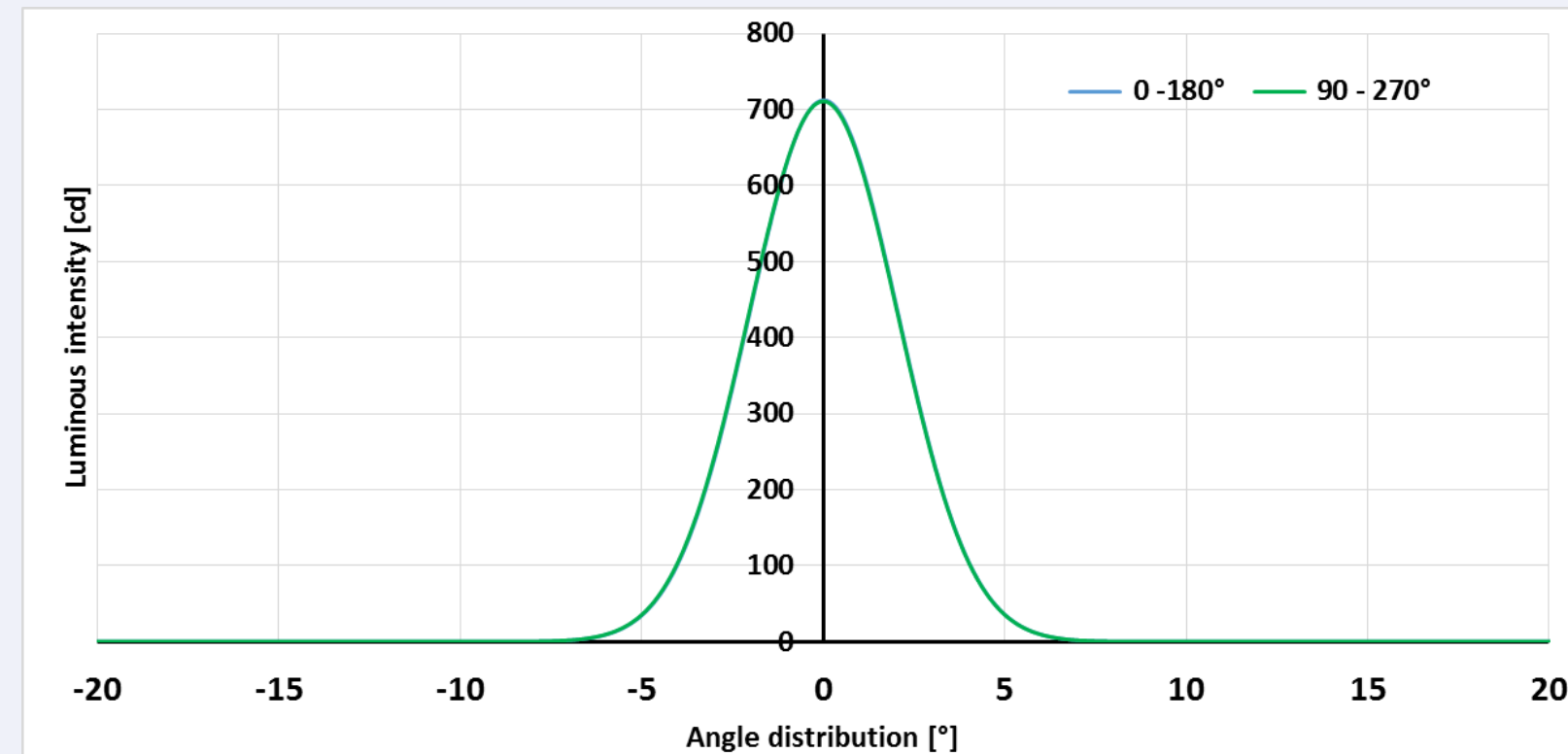

- Projection wall 3x3 m at 1m

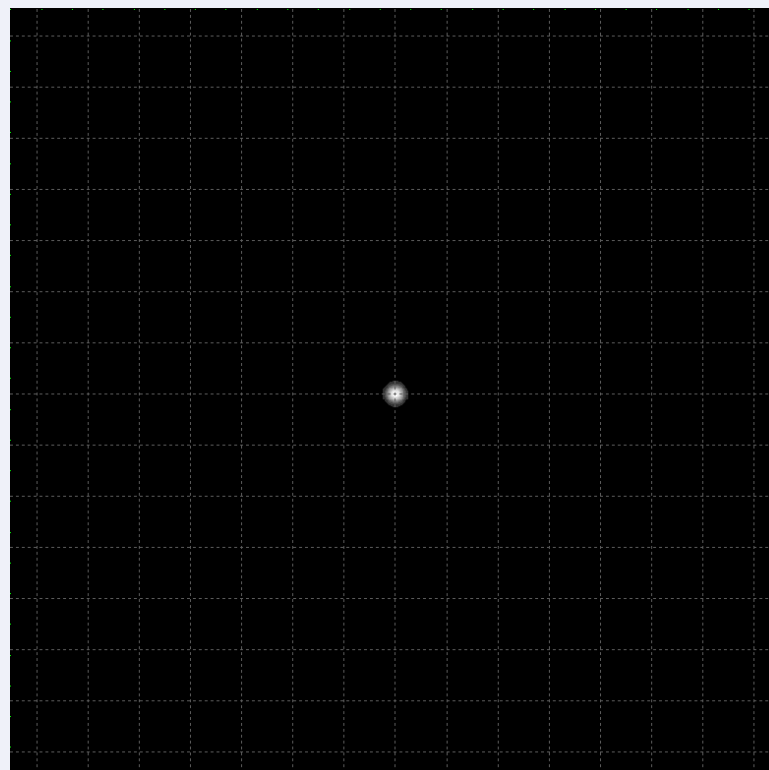

LED used for simulation	Cree XP-G
Luminous flux of LED [lm]	36
FWHM C ₀ [°]	6
FWHM C ₉₀ [°]	6

* The ratio between luminous flux on the projection wall (3x3 m at 1 m) and luminous flux of LED

A016 4923

REVISION HISTORY			
REV	DESCRIPTION	DATE	APPROVED

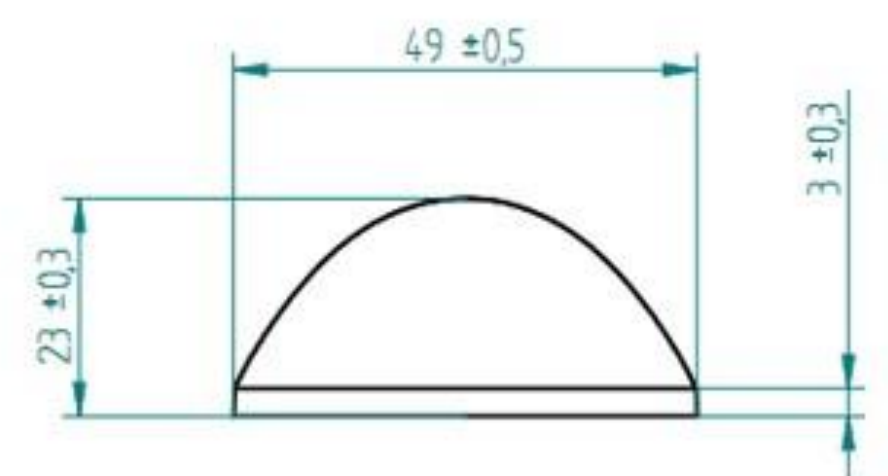

SCALE 1:2

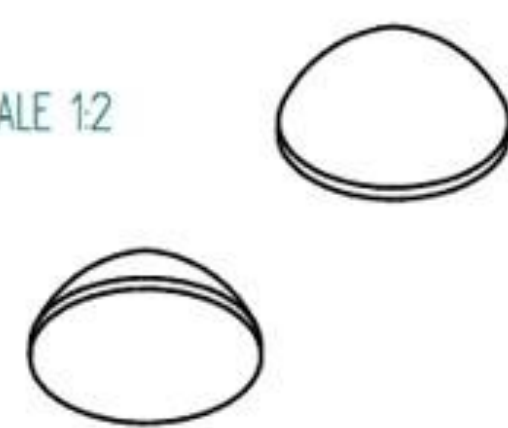

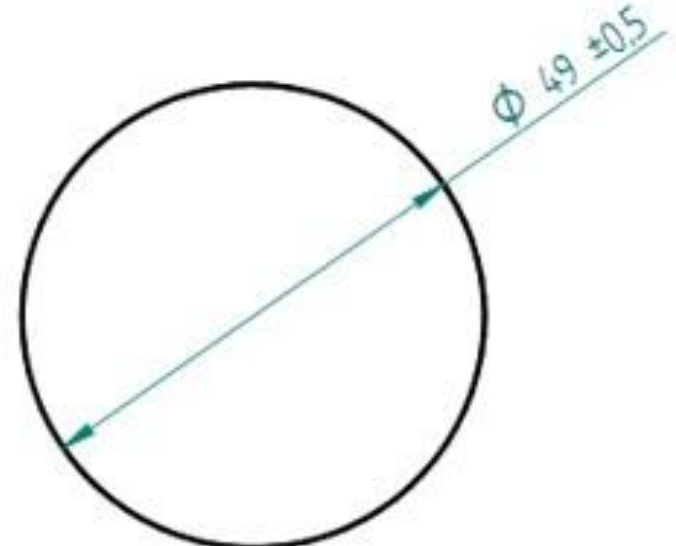

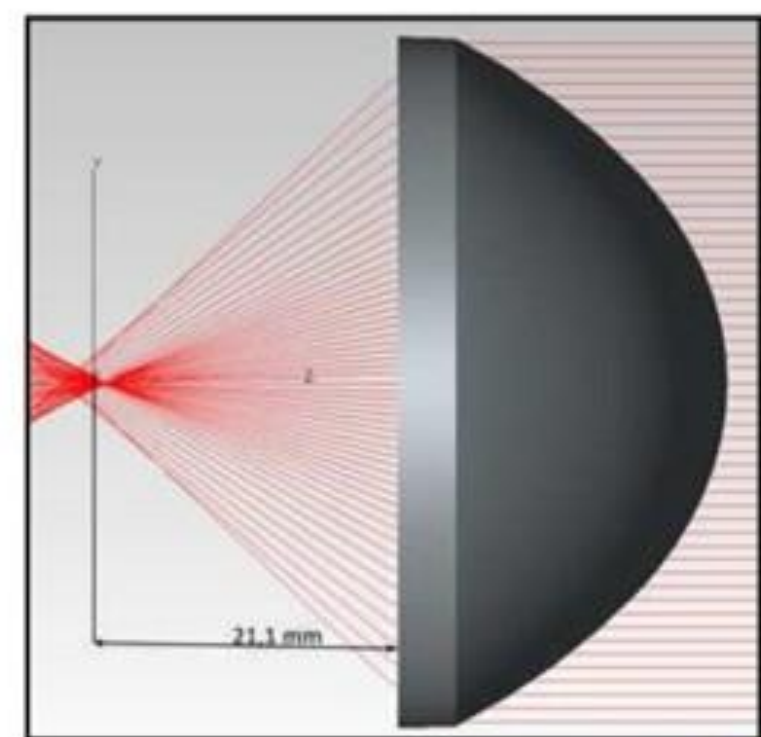

Glass: LIBA or alternative (nd = 1,521)

DRAWN	NAME	DATE	 A016 4923
CHECKED	ku/ky	05/14/20	
ENG APPR			
MGR APPR			
UNLESS OTHERWISE SPECIFIED DIMENSIONS ARE IN MILLIMETERS			
SCALE		WEIGHT 66 g	SHEET 1 OF 1

A016 4923 – simulation results

- Polar Candela Distribution Plot

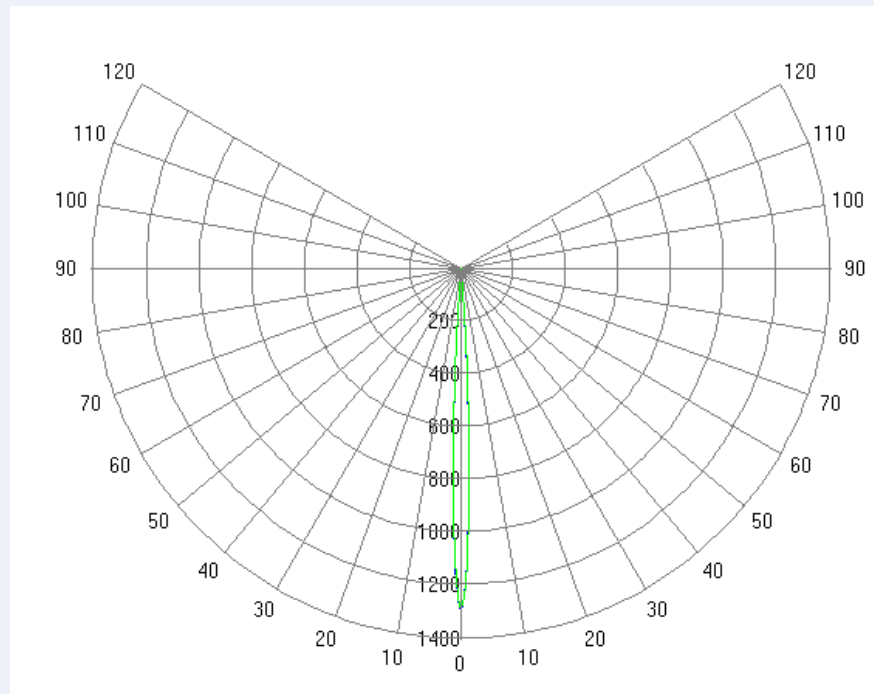

- Rectangular Candela Distribution Plot

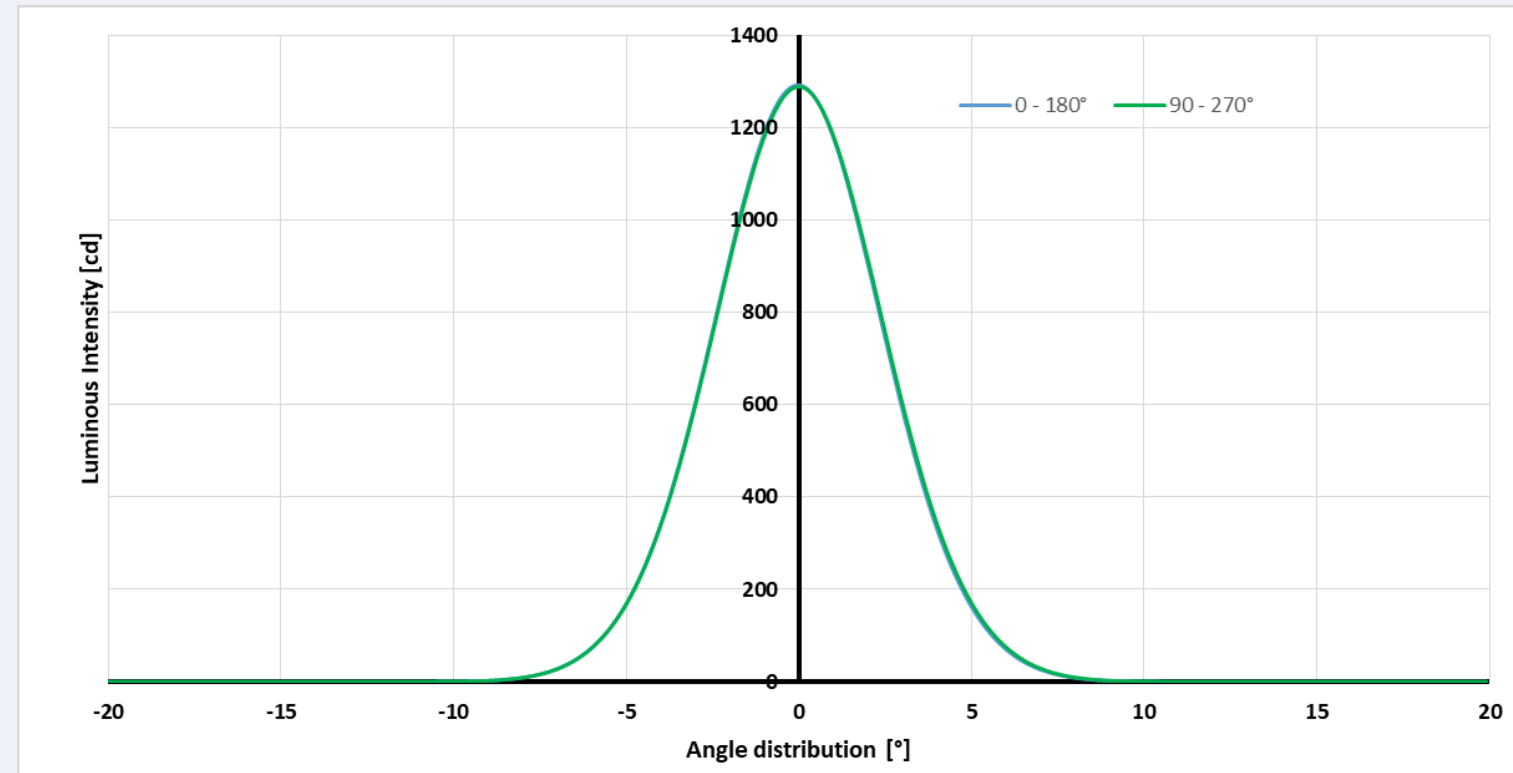

- Projection wall 3x3 m at 1m

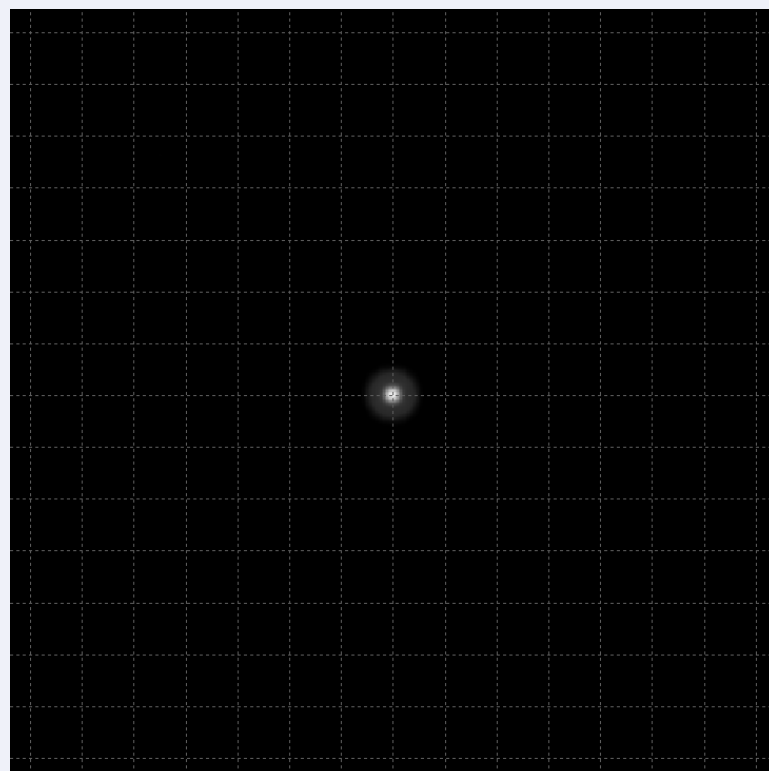

LED used for simulation	Cree XP-G
Luminous flux of LED [lm]	36
FWHM Co [°]	5,6
FWHM C90 [°]	5,6

* The ratio between luminous flux on the projection wall (3x3 m at 1 m) and luminous flux of LED

A019 5322

REVISION HISTORY			
REV	DESCRIPTION	DATE	APPROVED

Technical drawing of the lens showing dimensions: (21,26) for height, (49,2) for diameter, 3 ± 0,2 for thickness, 53 ± 0,15 for diameter, and (88°) for angle.

Ray diagram showing light rays passing through the lens and converging to a focal point at a distance of 25 units.

Top view of the lens showing diameters: (Φ 49,2) for the outer diameter and Φ 53 ± 0,15 for the inner diameter.

3D perspective view of the lens.

material : GLASS nd=1,520

DRAWN	jkocarek	DATE	06/12/25		
CHECKED				TITLE	
ENG APPR				A019 5322	
MGR APPR				SIZE	DWG NO
UNLESS OTHERWISE SPECIFIED DIMENSIONS ARE IN MILLIMETERS				A4	Aspheric Lens
				FILE NAME: A0195322 z vykresudft	REV
				SCALE:	WEIGHT:
					SHEET 1 OF 1

A019 5322 – simulation results

- Polar Candela Distribution Plot

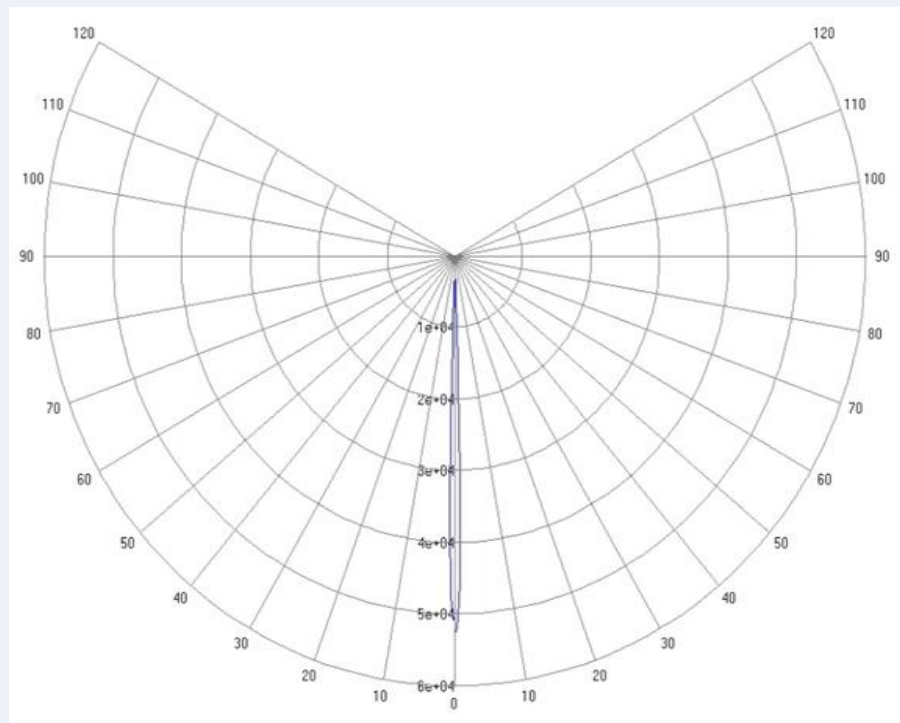

- Rectangular Candela Distribution Plot

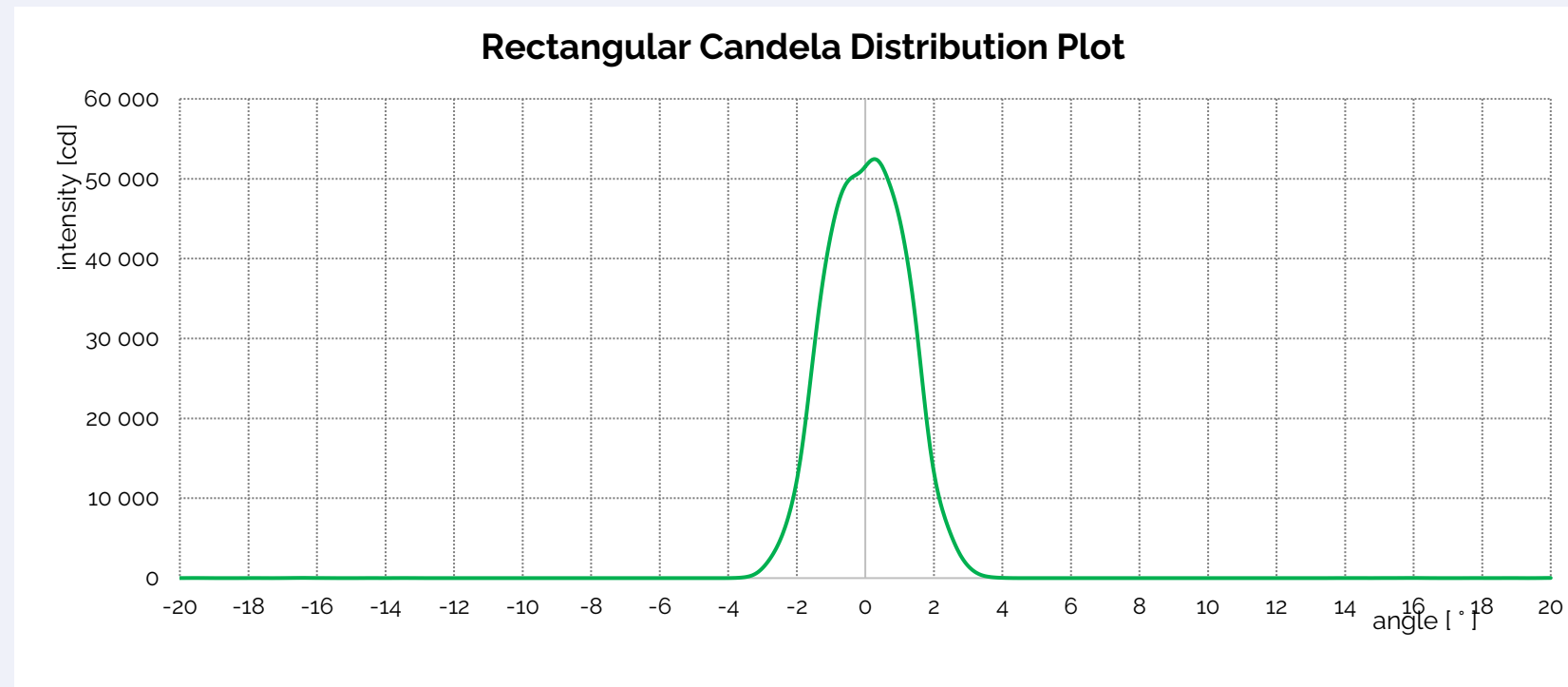

- Projection wall 3x3 m at 1m

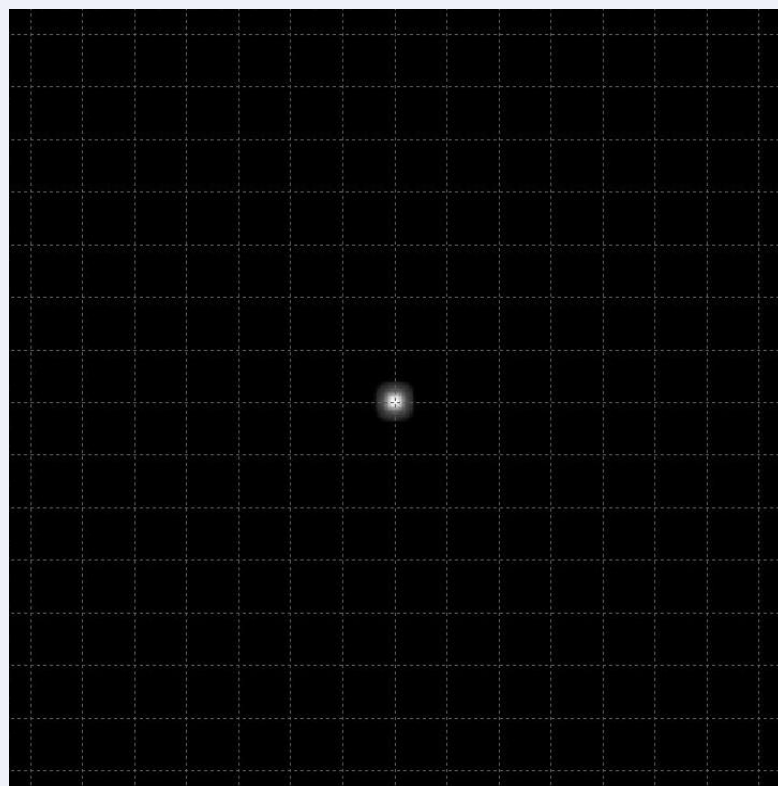

LED used for simulation	Cree XP-G4
Luminous flux of LED [lm]	350
FWHM Co [°]	3
FWHM C180 [°]	3

A034 1807

REVISION HISTORY			
REV.	DESCRIPTION	DATE	APPROVED

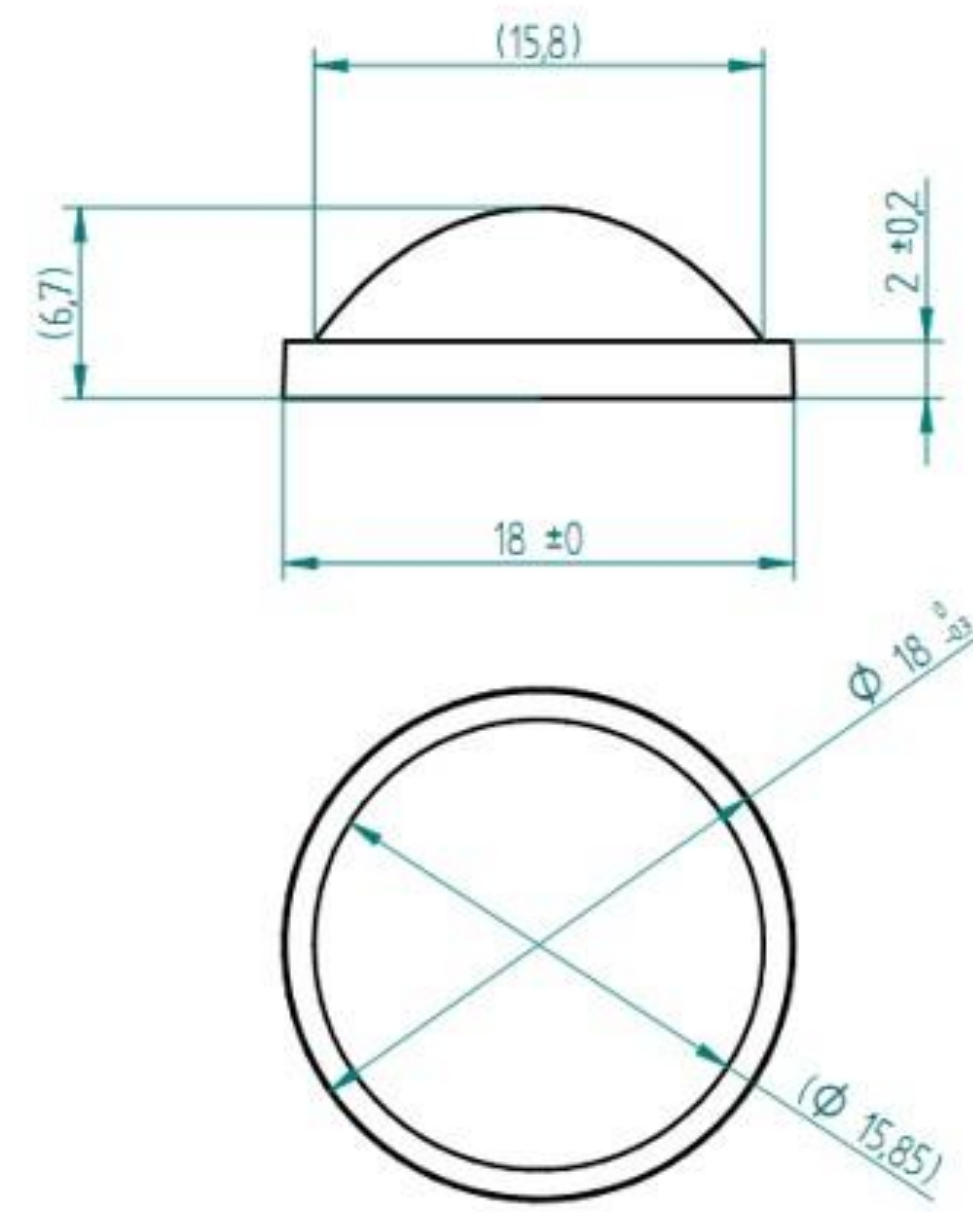

SCALE 2:1

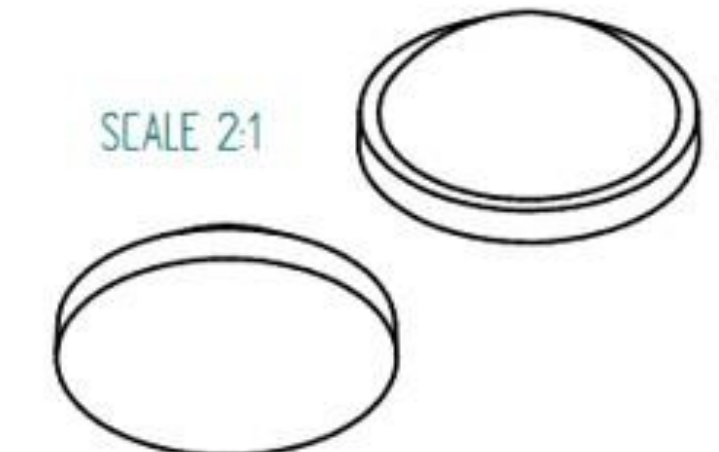

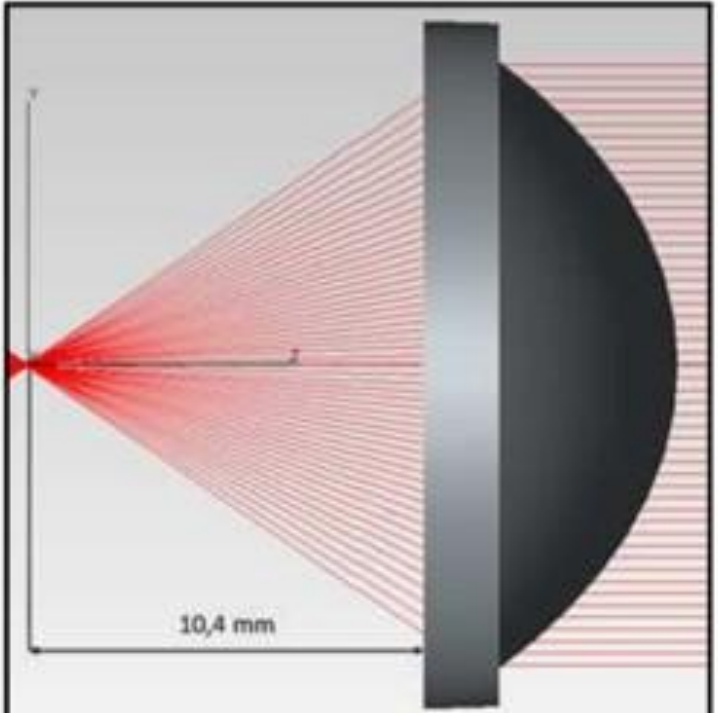

Glass: LIBA or alternative (nd = 1,521)

DRAWN	kny/ky	DATE	05/14/20
CHECKED			
ENG APPR			
MGR APPR			



A034 1807

SIZE	A4	DATE	
FILE NAME	A034_small.dwg		
SCALE	WEIGHT	3 g	SHEET 1 OF 1

A034 1807 – simulation results

- Polar Candela Distribution Plot

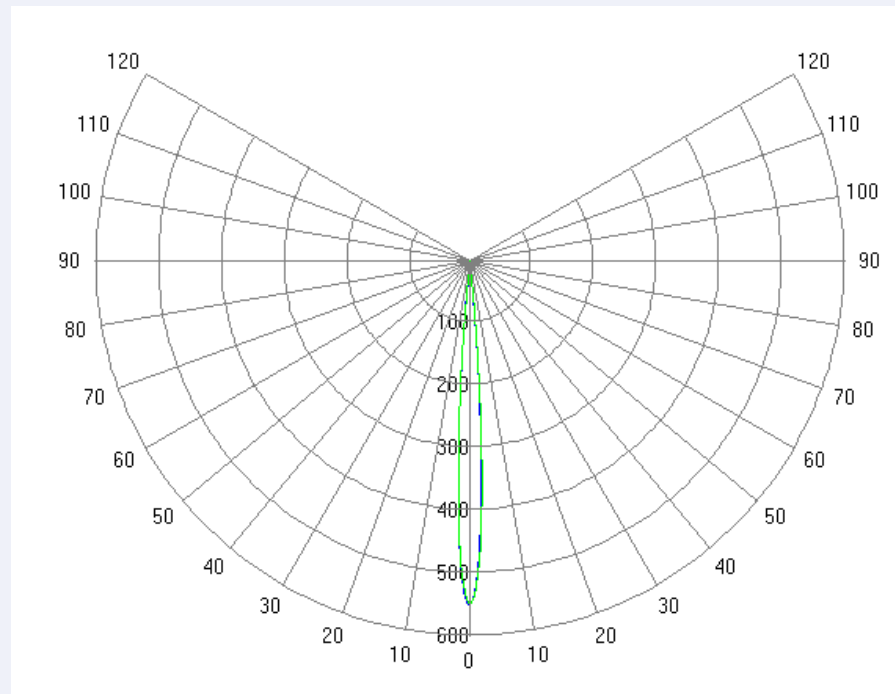

- Rectangular Candela Distribution Plot

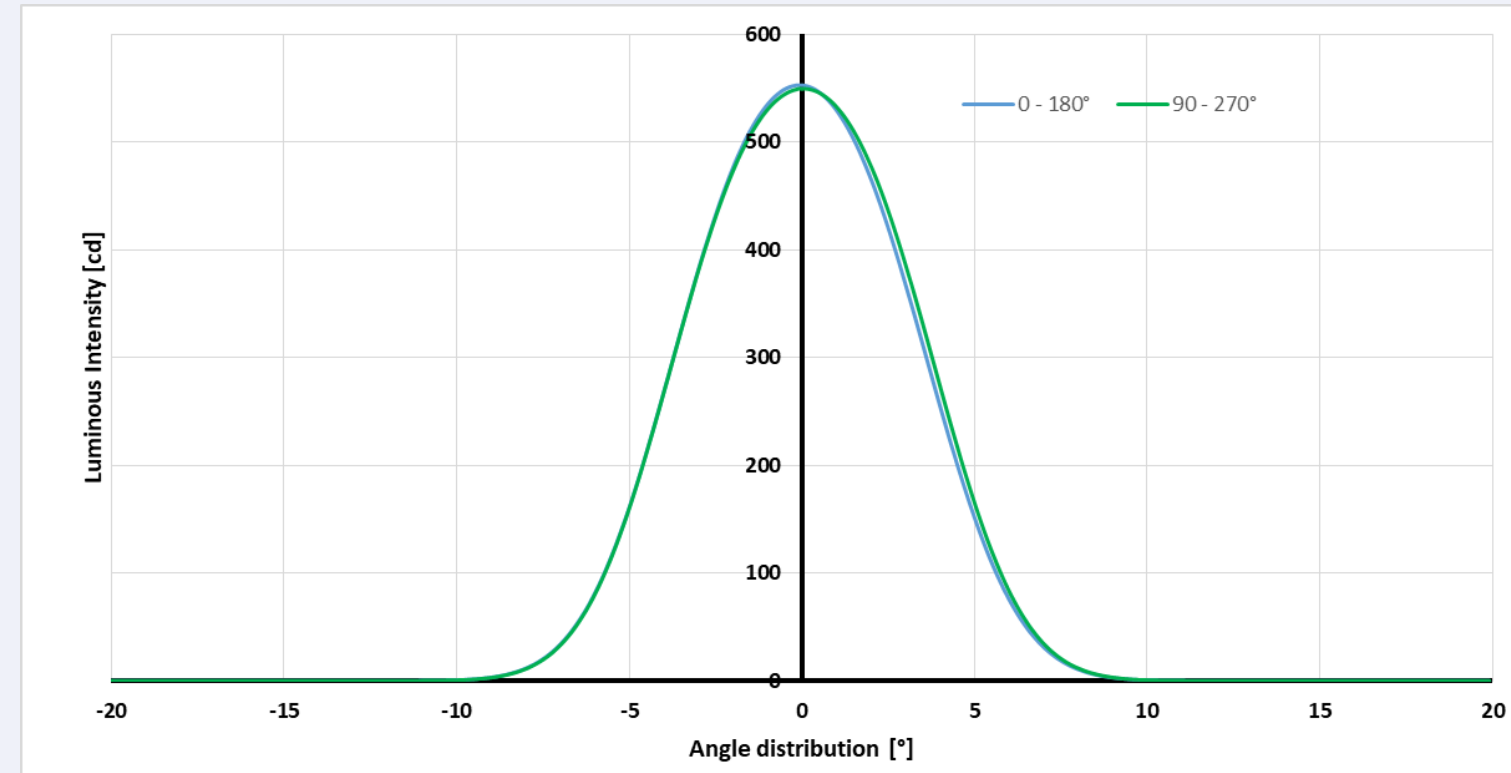

- Projection wall 3x3 m at 1m

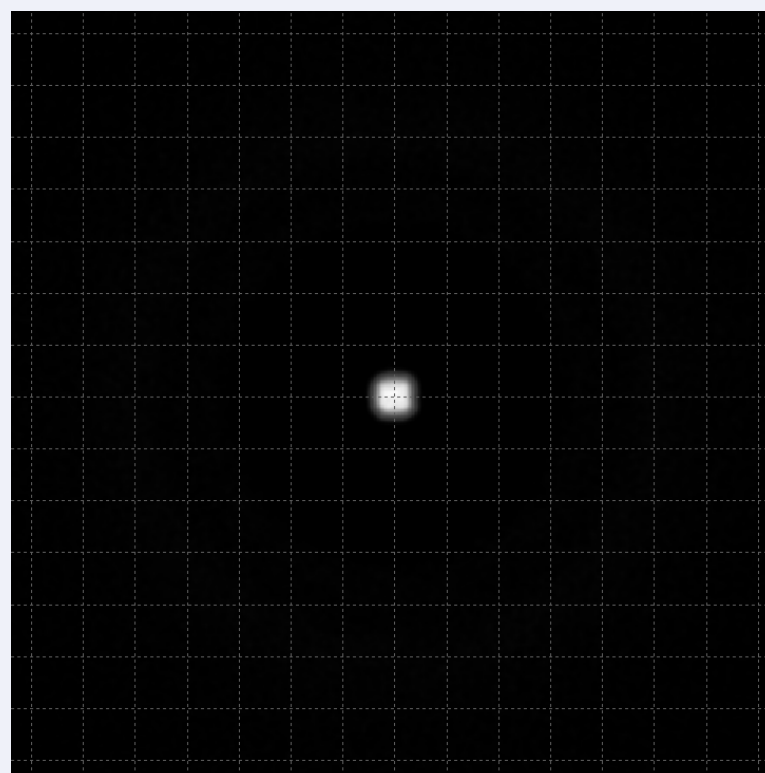

LED used for simulation	Cree XP-G
Luminous flux of LED [lm]	36
FWHM C ₀ [°]	8
FWHM C ₉₀ [°]	8

* The ratio between luminous flux on the projection wall (3x3 m at 1 m) and luminous flux of LED

A053 1807

REVISION HISTORY			
REV.	DESCRIPTION	DATE	APPROVED

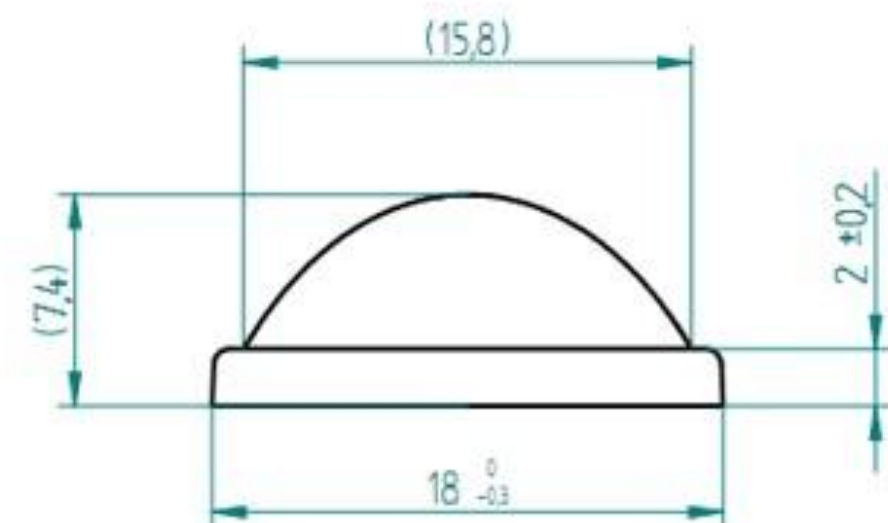
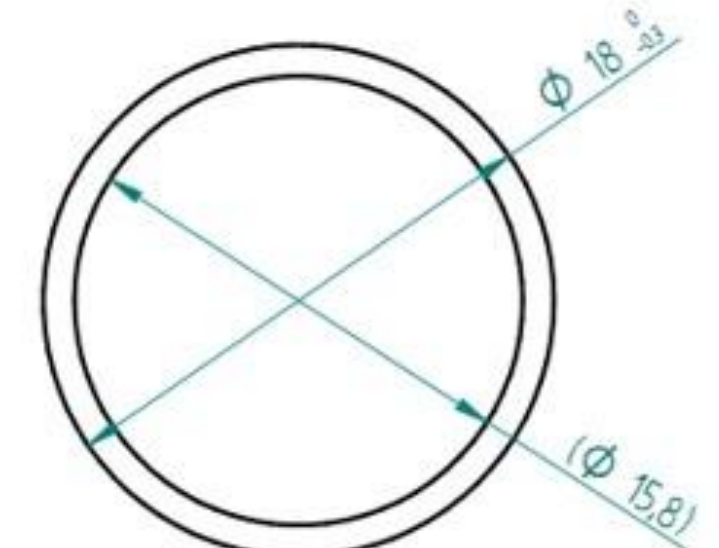
SCALE 2:1



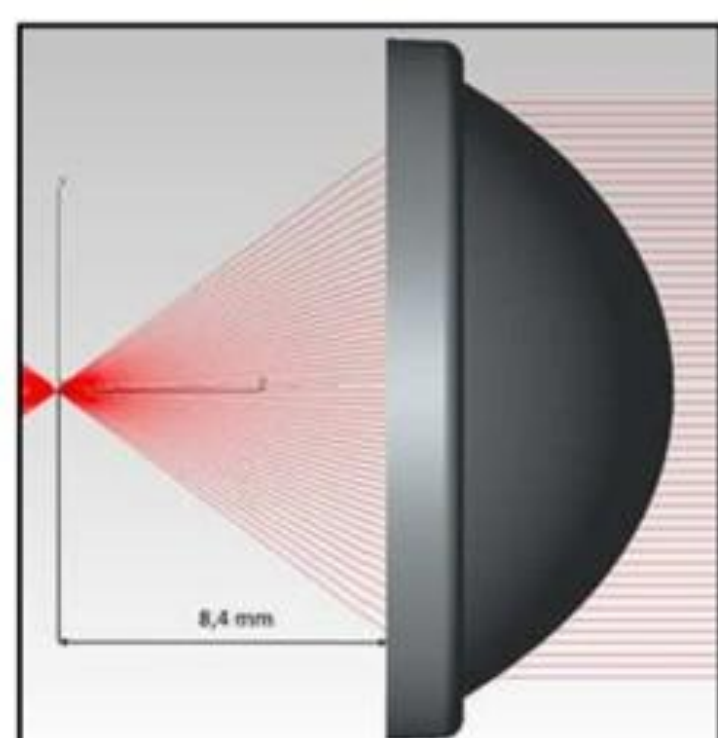

DRAWN	NAME	DATE	 A053 1807
CHECKED			
ENG APPR			
MGR APPR			
UNLESS OTHERWISE SPECIFIED DIMENSIONS ARE IN MILLIMETERS			
FILE NAME: A053_enu107		SCALE	WEIGHT: 3 g
		SHEET 1 OF 1	

Glass: LIBA or alternative (nd = 1,521)

A053 1807 – simulation results

- Polar Candela Distribution Plot

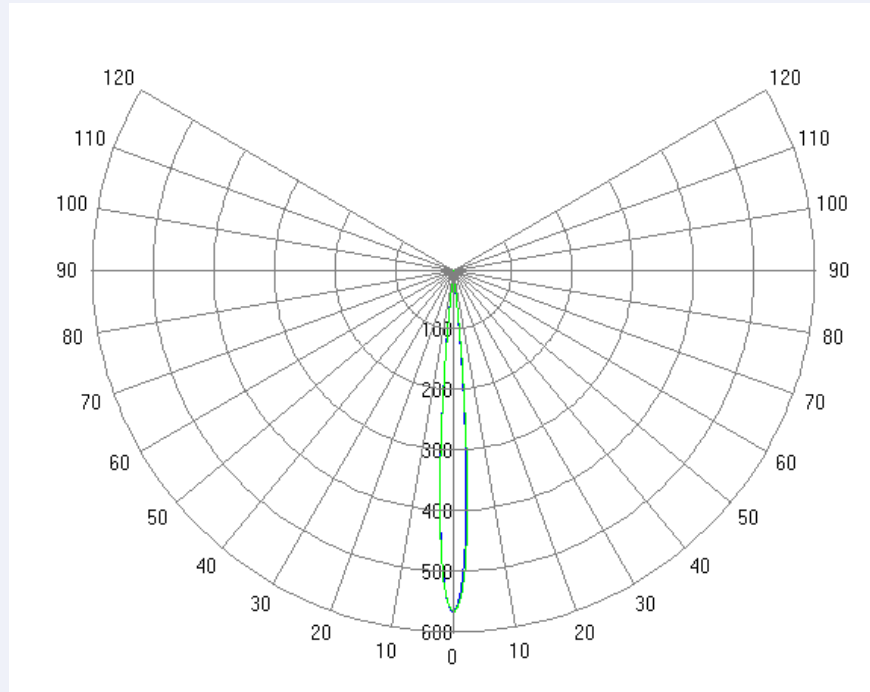

- Rectangular Candela Distribution Plot

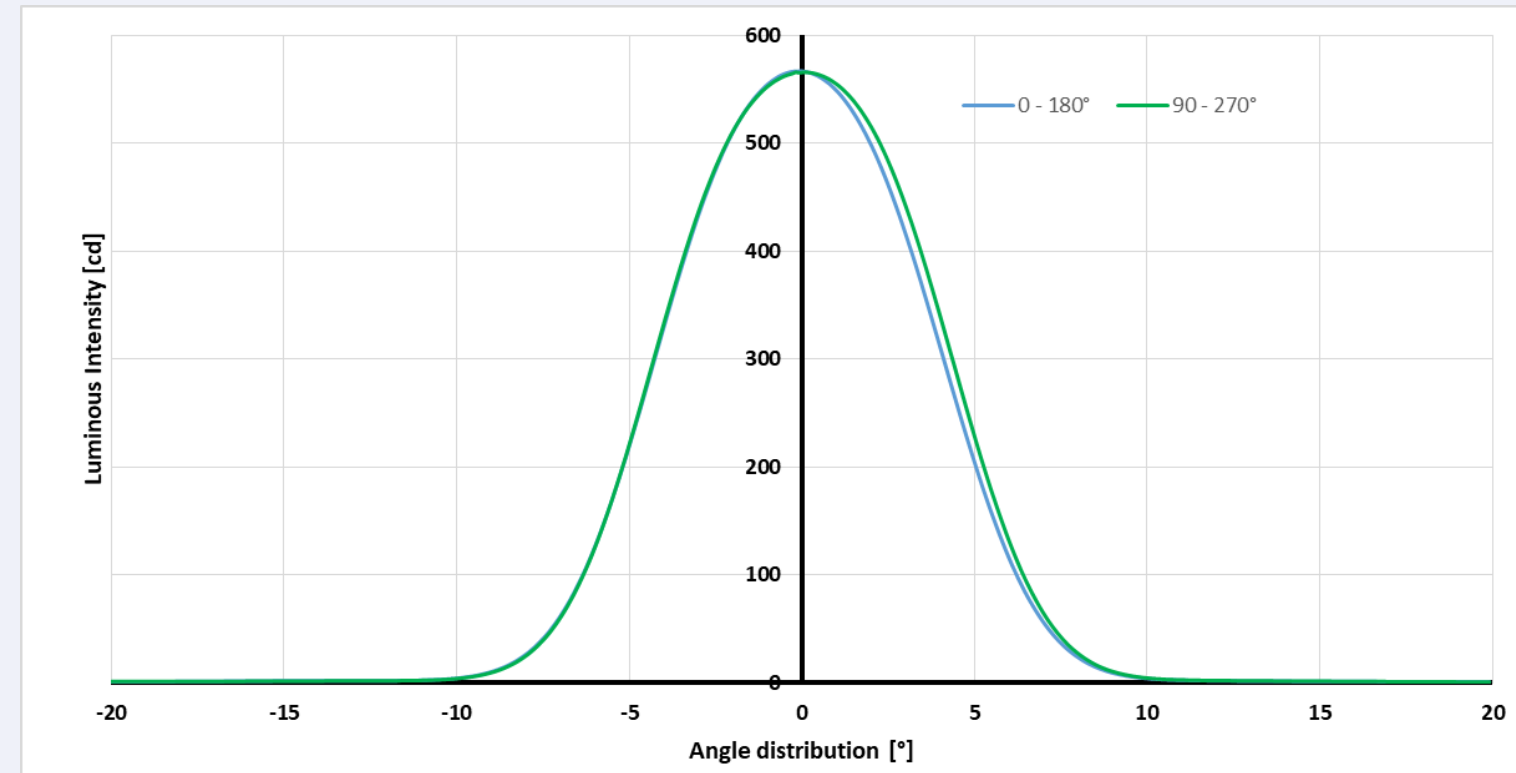

- Projection wall 3x3 m at 1m

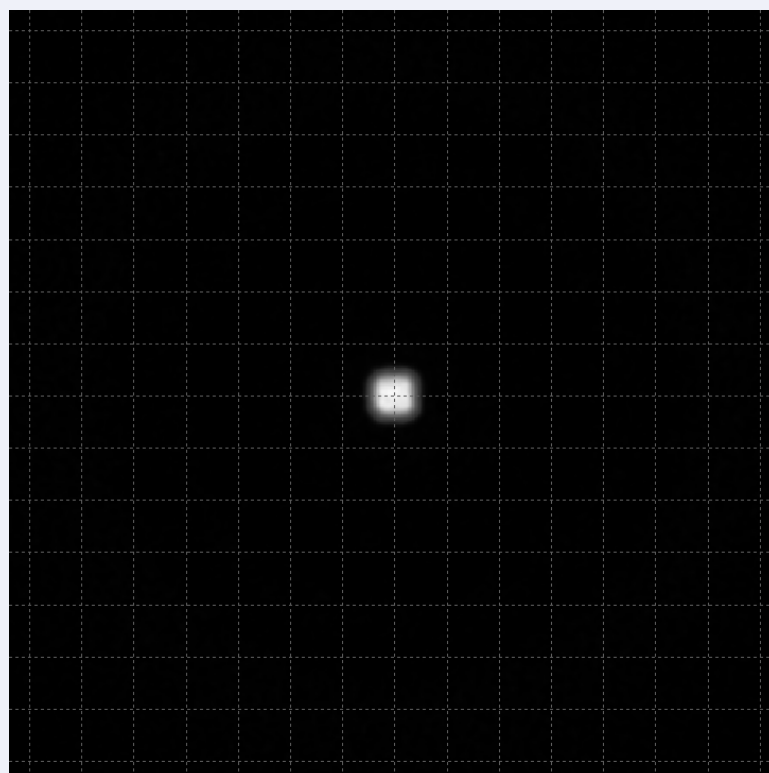

LED used for simulation	Cree XP-G
Luminous flux of LED [lm]	36
FWHM C ₀ [°]	9
FWHM C ₉₀ [°]	9

* The ratio between luminous flux on the projection wall (3x3 m at 1 m) and luminous flux of LED

A068 6015

REVISION HISTORY			
REV	DESCRIPTION	DATE	APPROVED

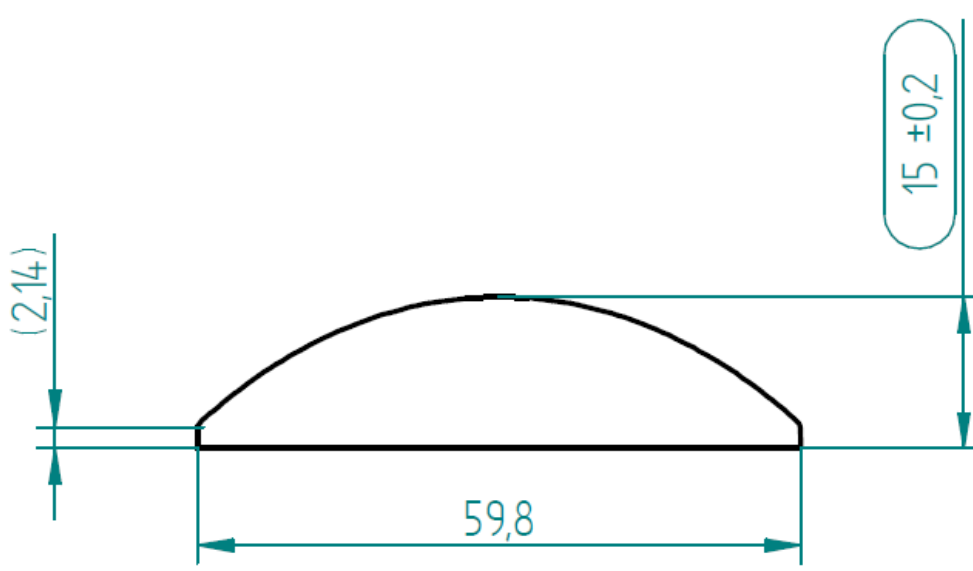
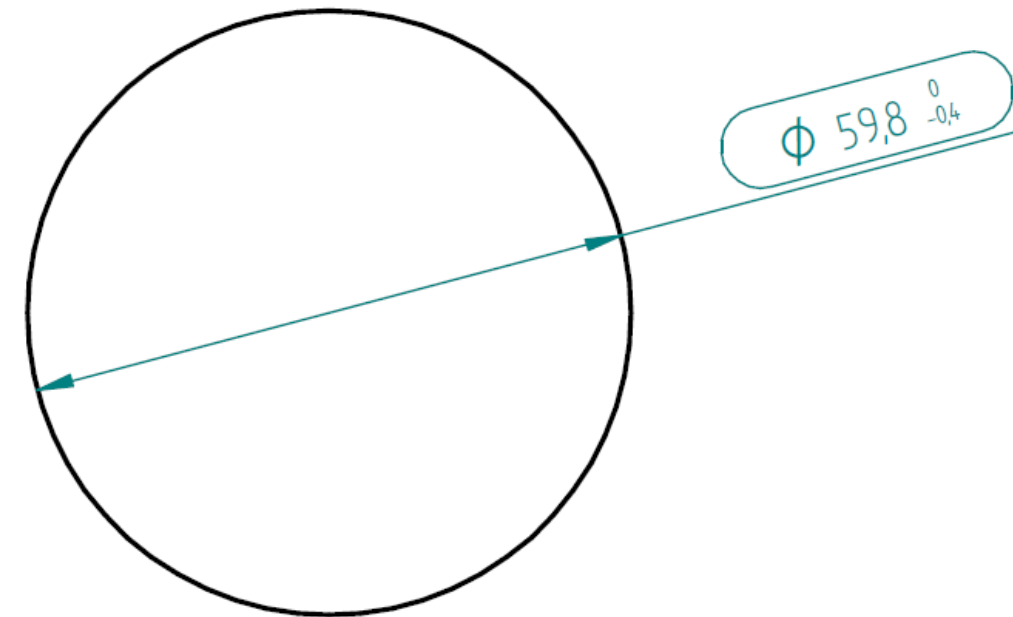

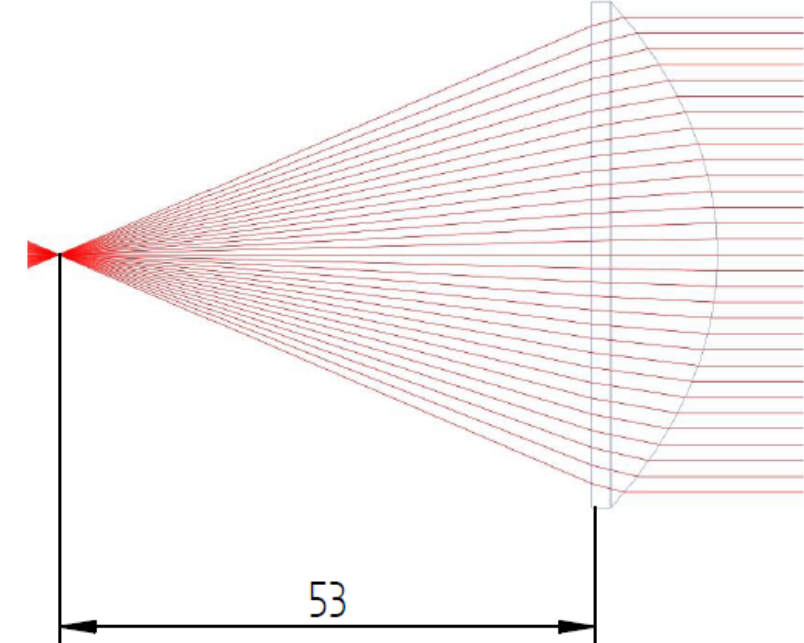
material : glass nd=1,520

	NAME	DATE		
DRAWN	jkocnrek	06/09/25		TITLE
CHECKED				aspheric lens 60BF53
ENG APPR				SIZE
MGR APPR				A4
UNLESS OTHERWISE SPECIFIED DIMENSIONS ARE IN MILLIMETERS			DWG NO	REV
			A068 6015	
			FILE NAME: A068 6015.dft	
			SCALE:	WEIGHT:
				SHEET 1 OF 1

A068 6015 – simulation results

- Polar Candela Distribution Plot

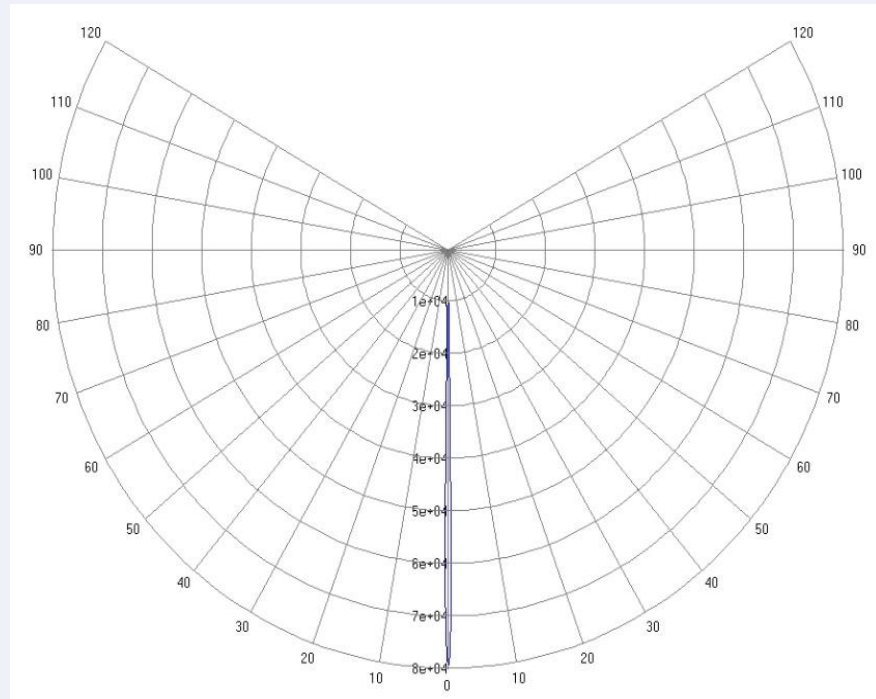

- Rectangular Candela Distribution Plot

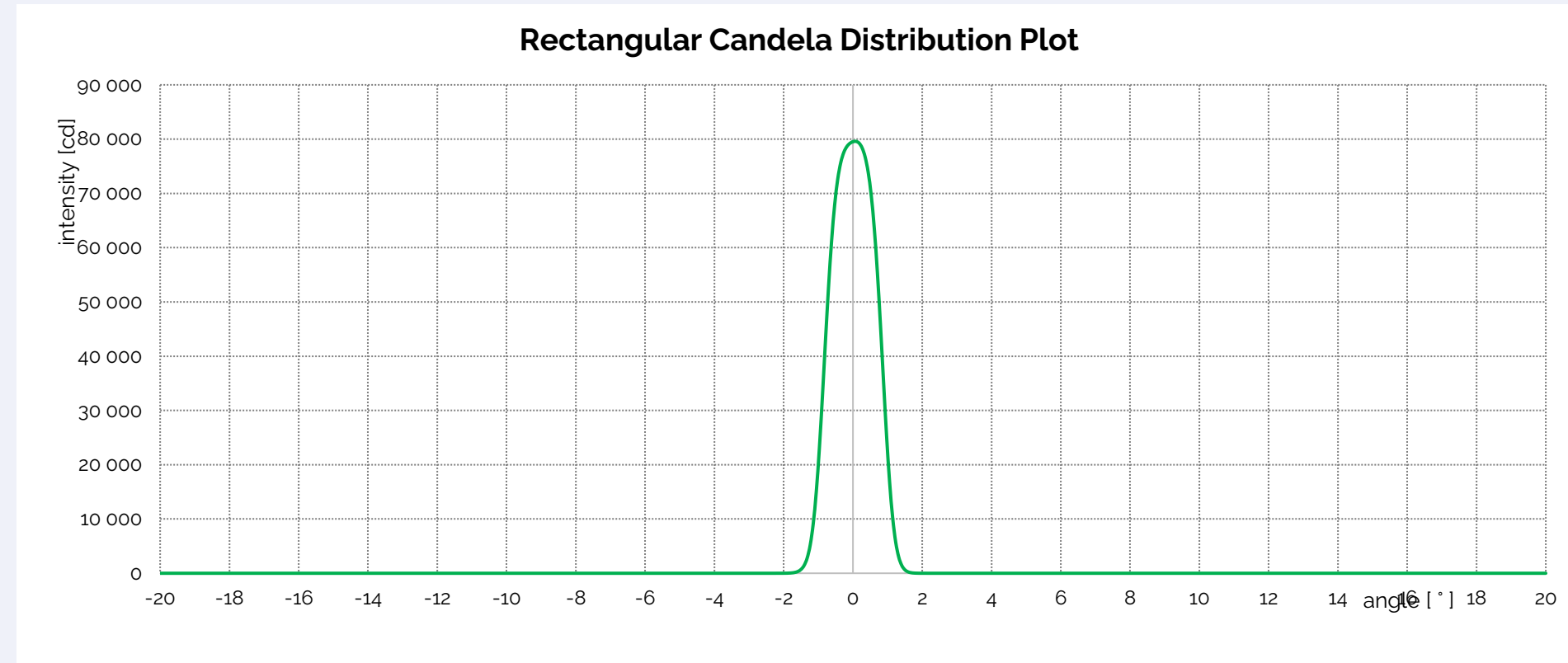

- Projection wall 3x3 m at 1m

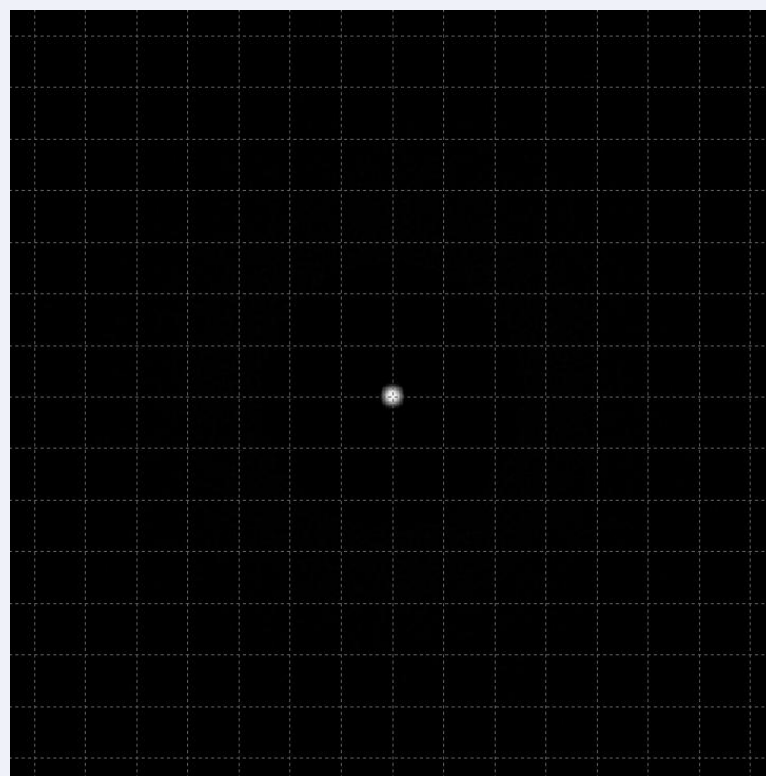

LED used for simulation	Cree XP-G4
Luminous flux of LED [lm]	350
FWHM Co [°]	2
FWHM C180 [°]	2

* The ratio between luminous flux on the projection wall (3x3 m at 1 m) and luminous flux of LED

A071 5224

REVISION HISTORY			
REV.	DESCRIPTION	DATE	APPROVED

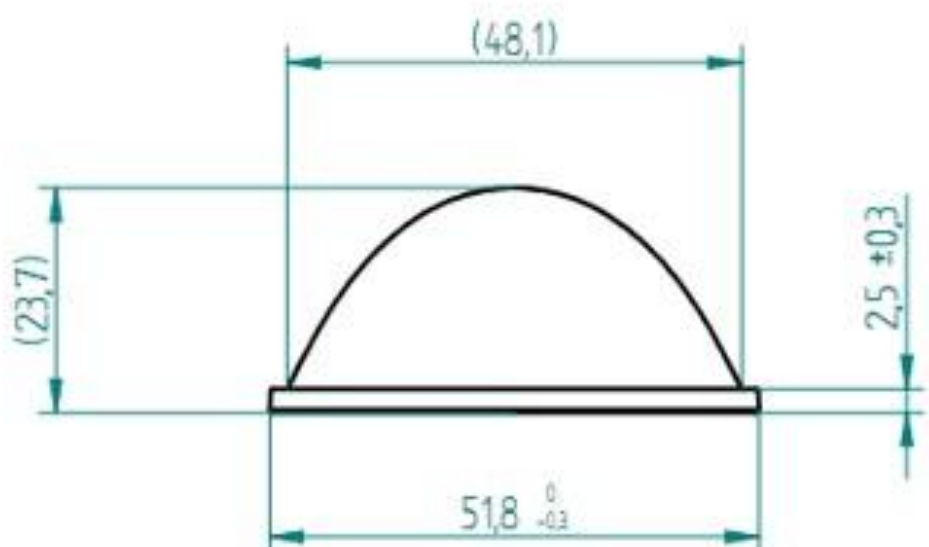
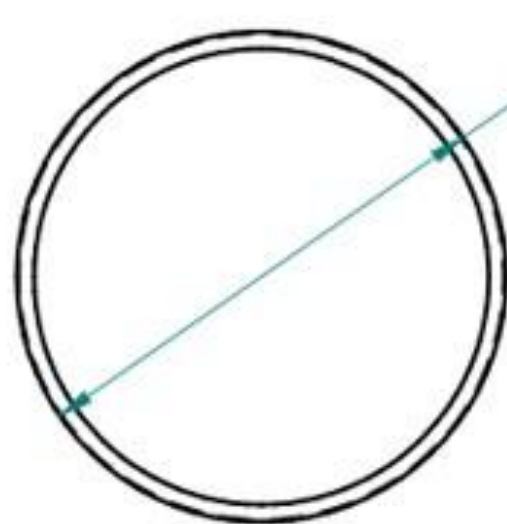



SCALE 1:2

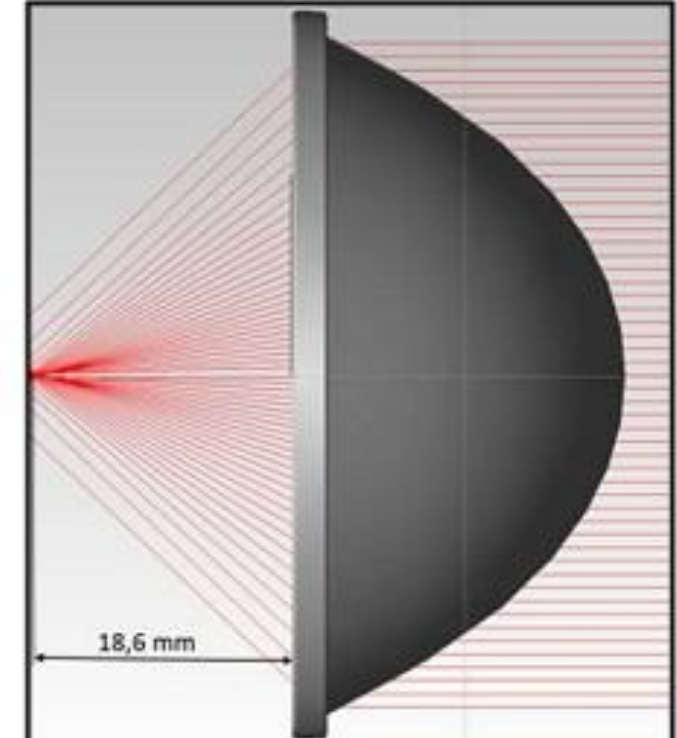



Glass: LIBA or alternative (nd = 1,521)

DRAWN	krutky	DATE	05/14/20	 A071 5224
CHECKED				
ENG APPR				
MGR APPR				
UNLESS OTHERWISE SPECIFIED DIMENSIONS ARE IN MILLIMETERS				SIZE: 44 FILE NAME: A071_uml.dwg SCALE: WEIGHT: 67 g SHEET 1 OF 1

A071 5224 – simulation results

- Polar Candela Distribution Plot

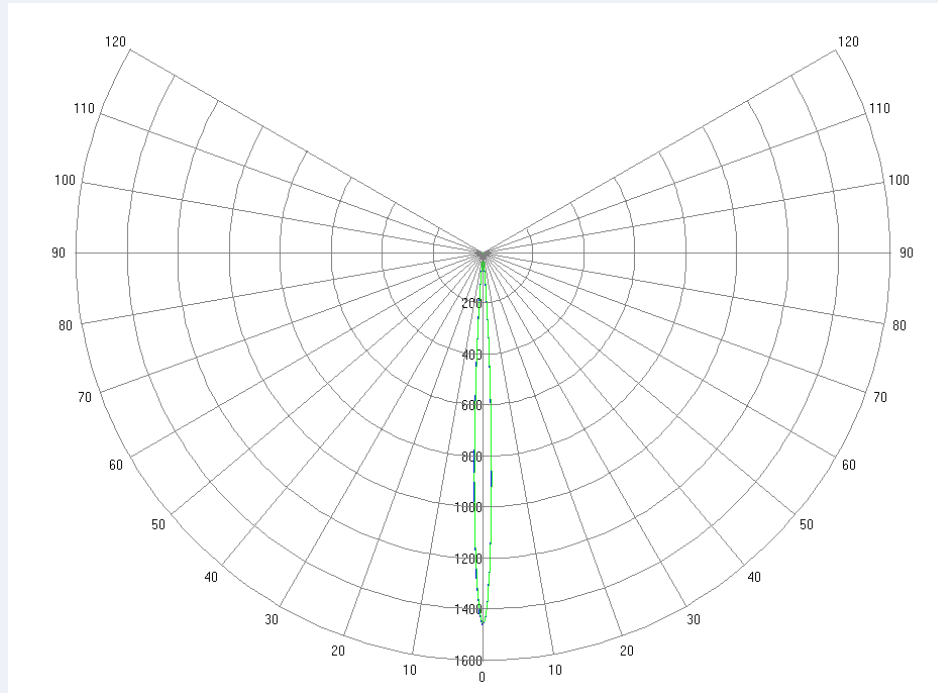

- Rectangular Candela Distribution Plot

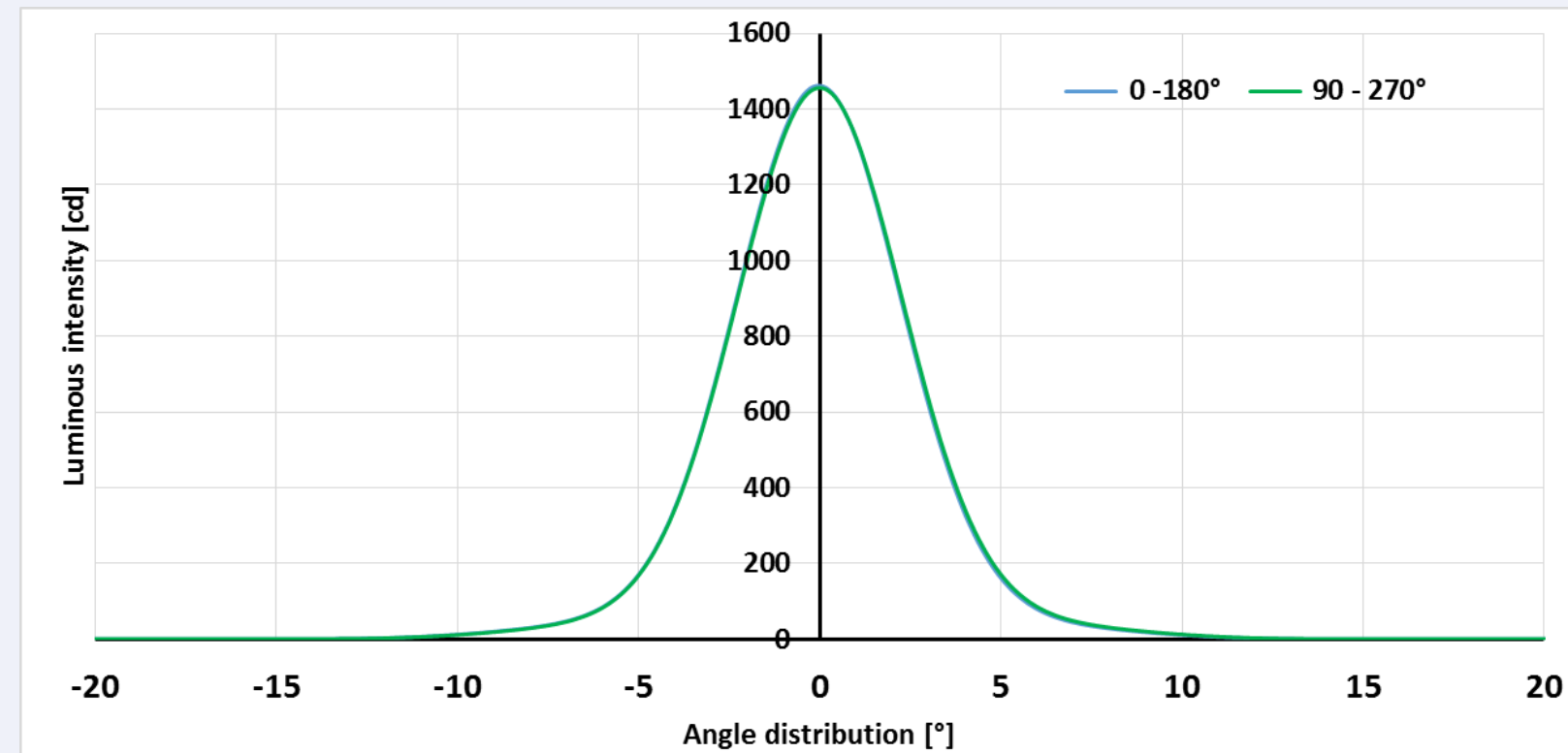

- Projection wall 3x3 m at 1m

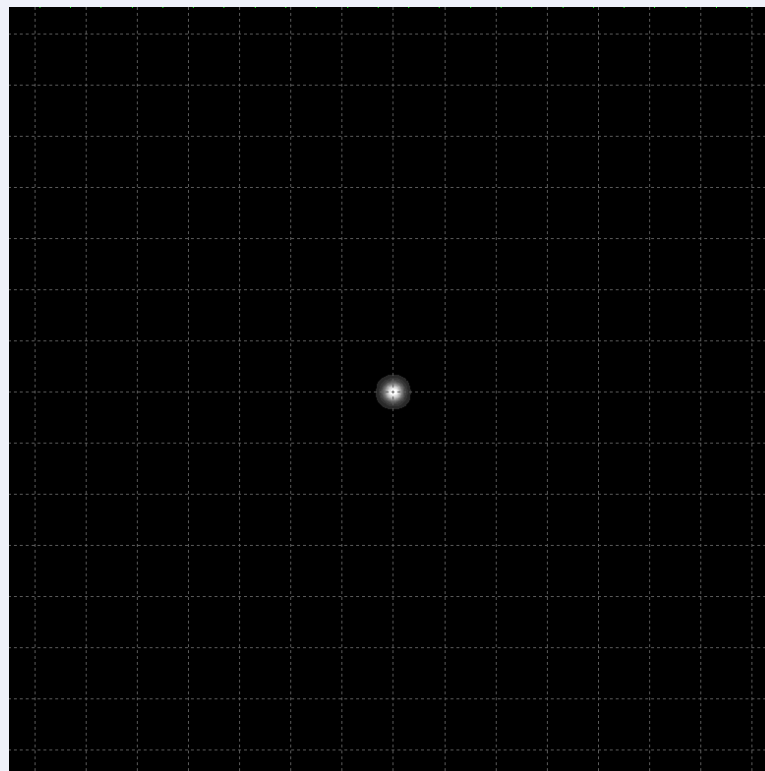

LED used for simulation	Cree XP-G
Luminous flux of LED [lm]	36
FWHM Co [°]	6
FWHM C90 [°]	6

* The ratio between luminous flux on the projection wall (3x3 m at 1 m) and luminous flux of LED

A079 6422

REVISION HISTORY			
REV.	DESCRIPTION	DATE	APPROVED

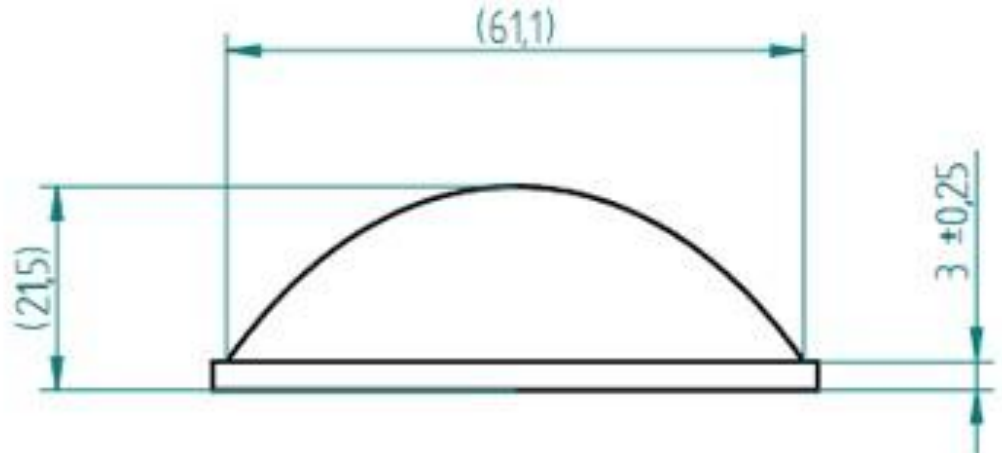
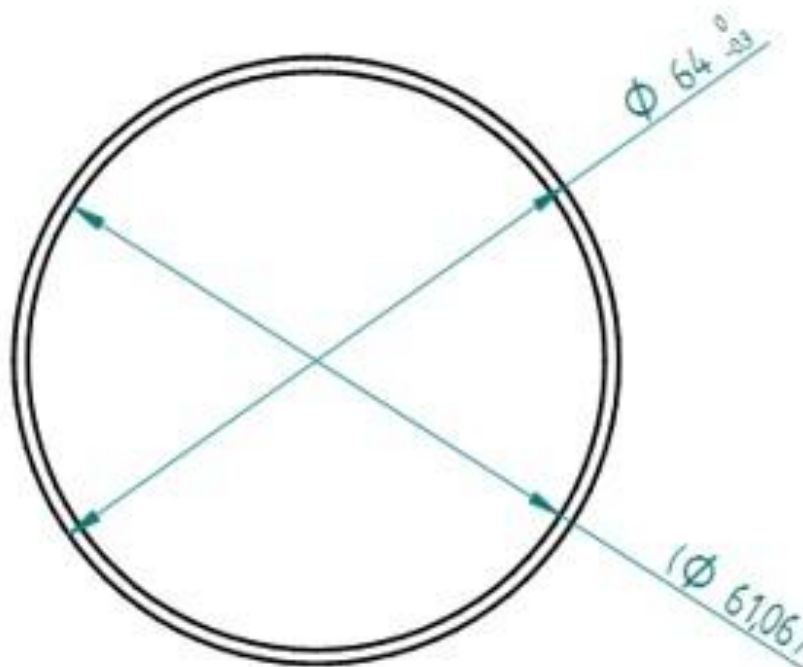



SCALE 1:2

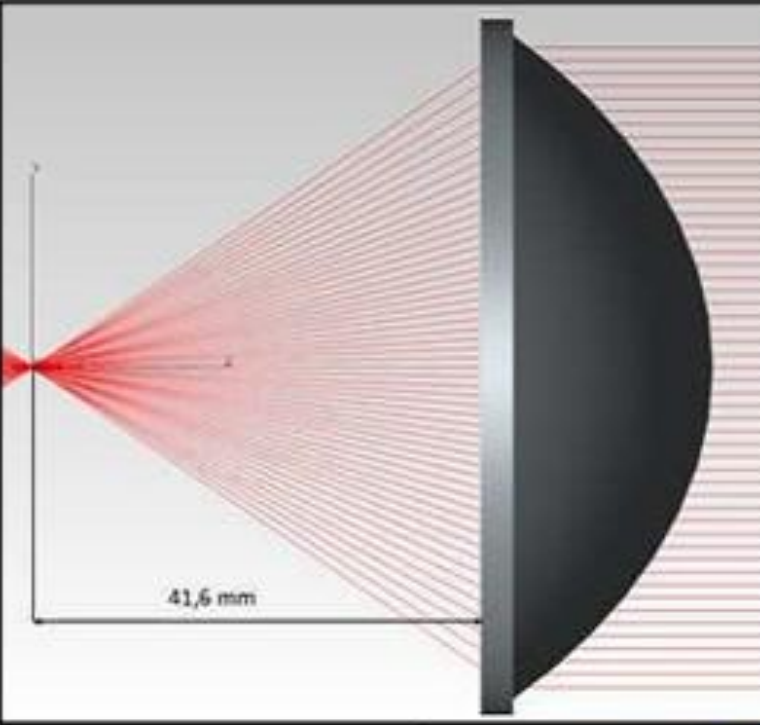

Glass: LIBA or alternative (nd = 1,521)



DRAW	krubry	15/11/20	 <p style="font-size: 1.2em; font-weight: bold;">A079 6422</p>															
CHKD/EC																		
ENG APPR																		
MGR APPR																		
UNLESS OTHERWISE SPECIFIED DIMENSIONS ARE IN MILLIMETERS			<table style="width: 100%; border-collapse: collapse;"> <tr> <td style="font-size: 0.8em;">SIZE</td> <td style="font-size: 0.8em;">Dwg No</td> <td style="font-size: 0.8em;">Rev</td> </tr> <tr> <td style="font-size: 0.8em;">A4</td> <td style="font-size: 0.8em;"> </td> <td style="font-size: 0.8em;"> </td> </tr> <tr> <td colspan="3" style="font-size: 0.8em;">FILE NAME: A079_enuL01</td> </tr> <tr> <td style="font-size: 0.8em;">SCALE</td> <td style="font-size: 0.8em;">WEIGHT</td> <td style="font-size: 0.8em;">SHEET 1 OF 1</td> </tr> <tr> <td style="font-size: 0.8em;"> </td> <td style="font-size: 0.8em;">58 g</td> <td style="font-size: 0.8em;"> </td> </tr> </table>	SIZE	Dwg No	Rev	A4			FILE NAME: A079_enuL01			SCALE	WEIGHT	SHEET 1 OF 1		58 g	
SIZE	Dwg No	Rev																
A4																		
FILE NAME: A079_enuL01																		
SCALE	WEIGHT	SHEET 1 OF 1																
	58 g																	

A079 6422 – simulation results

- Polar Candela Distribution Plot

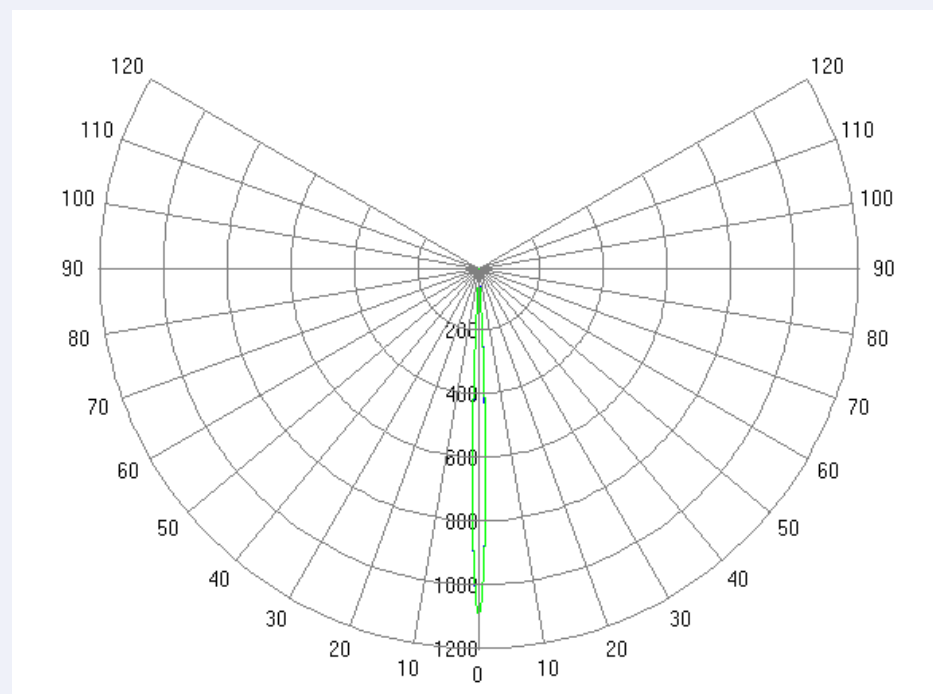

- Rectangular Candela Distribution Plot

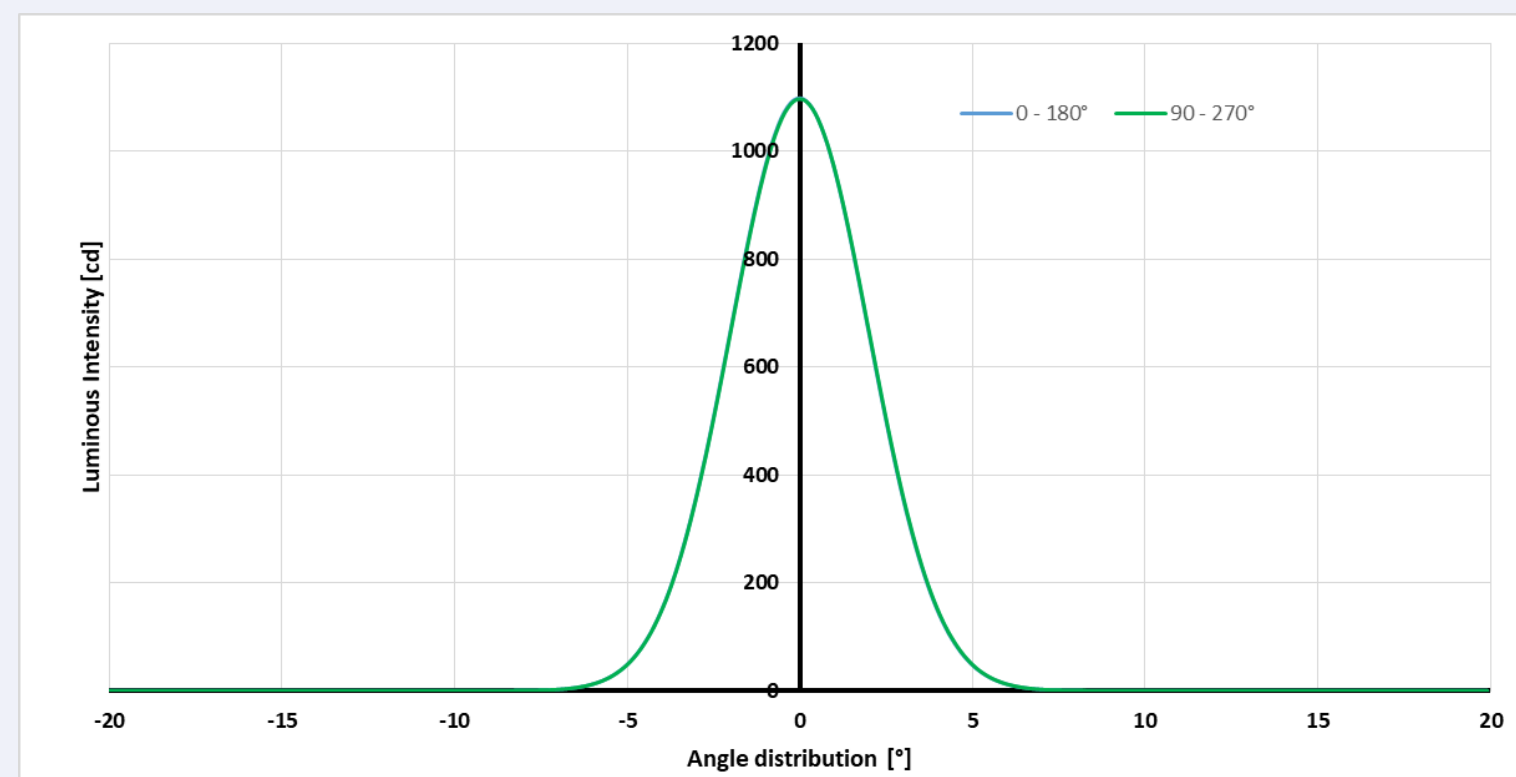

- Projection wall 3x3 m at 1m

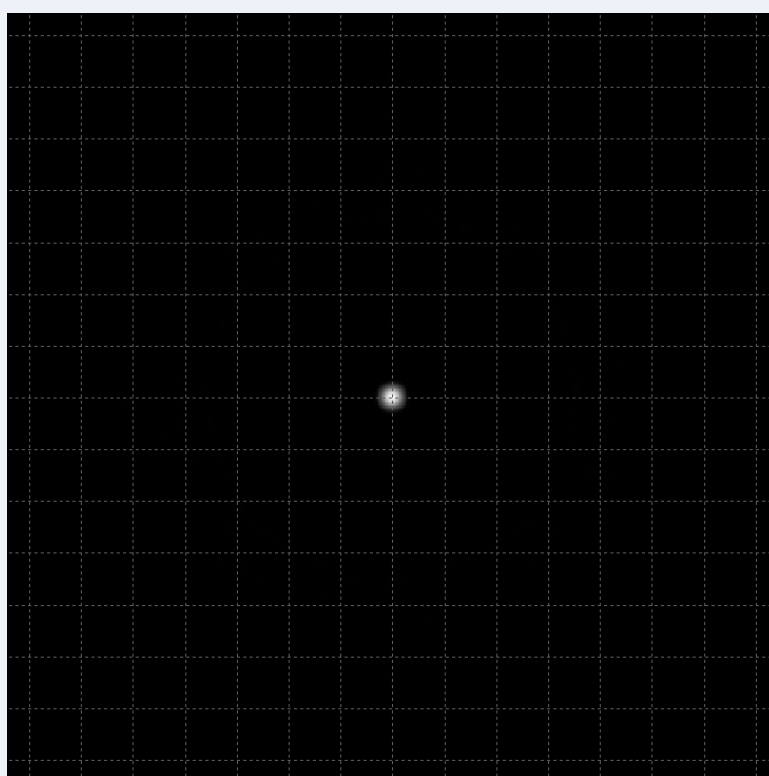

LED used for simulation	Cree XP-G
Luminous flux of LED [lm]	36
FWHM C ₀ [°]	5
FWHM C ₉₀ [°]	5

* The ratio between luminous flux on the projection wall (3x3 m at 1 m) and luminous flux of LED

A104 6616

REVISION HISTORY			
REV	DESCRIPTION	DATE	APPROVED

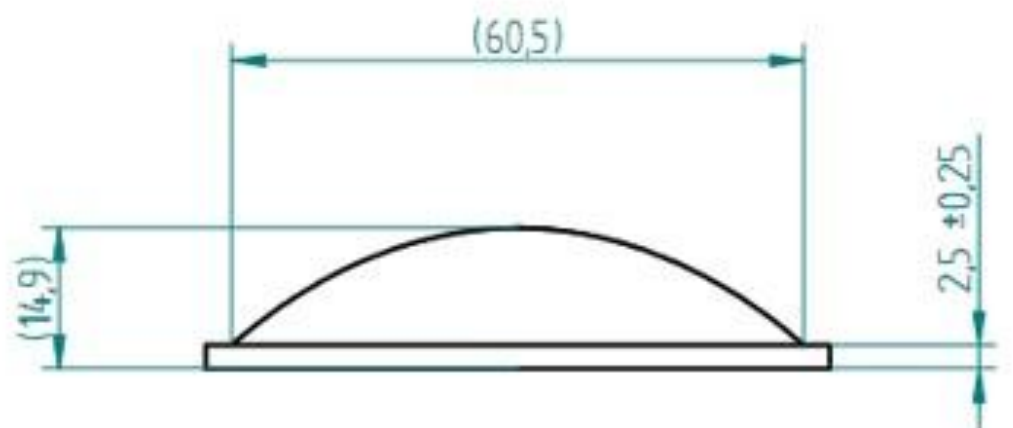
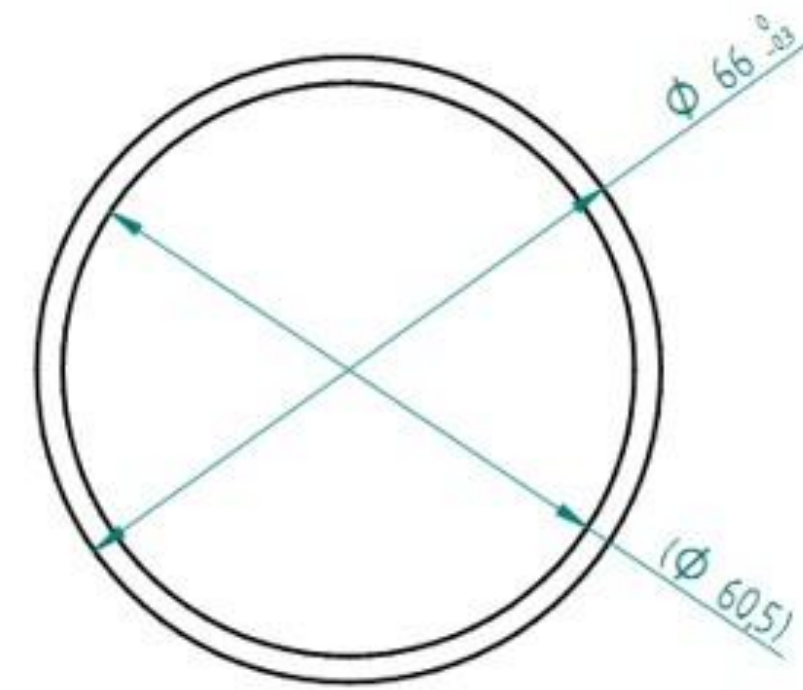
SCALE 1:2



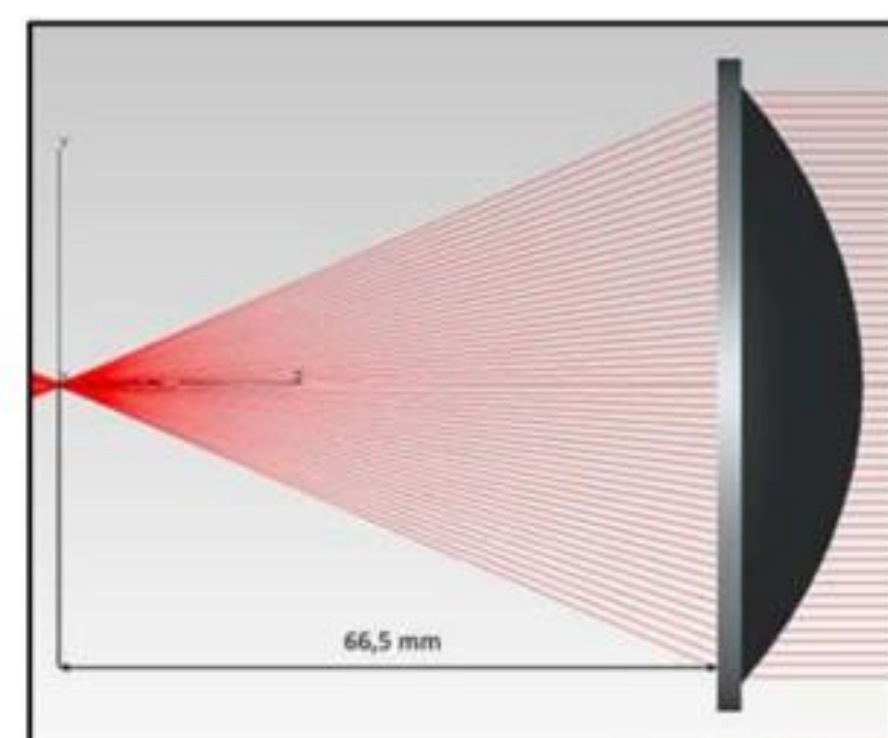

DRAWN	NAME	DATE	
	krutky	05/14/20	
CHECKED			
ENG APPR			
MGR APPR			
<small>UNLESS OTHERWISE SPECIFIED DIMENSIONS ARE IN MILLIMETERS</small>			A104 6616
<small>SCALE: WEIGHT: 65 g SHEET 1 OF 1</small>			<small>FILE NAME: A104_enu1.tif</small>

Glass: LIBA or alternative (nd = 1,521)

A104 6616 – simulation results

- Polar Candela Distribution Plot

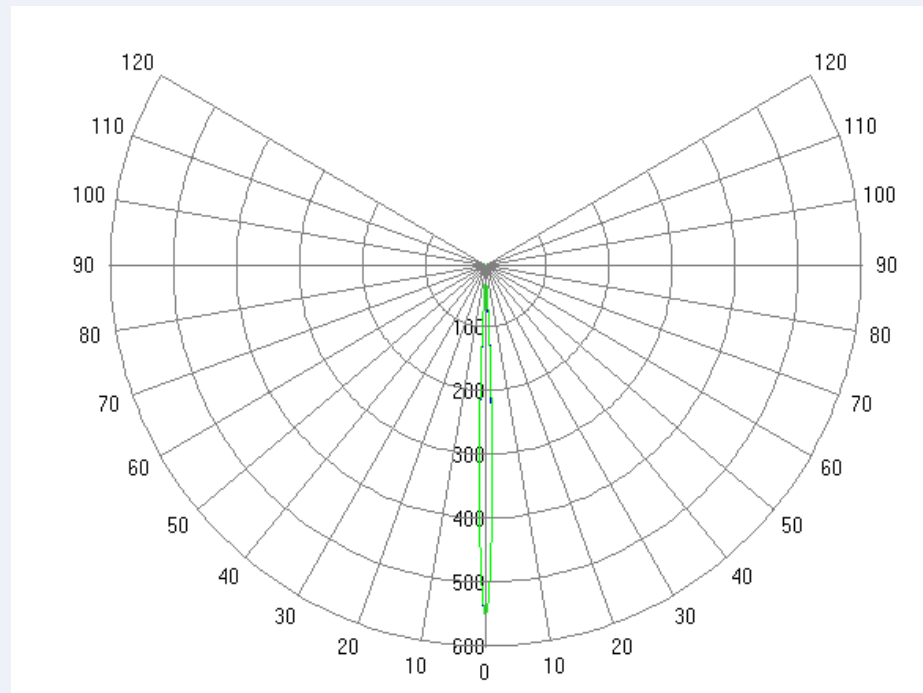

- Rectangular Candela Distribution Plot

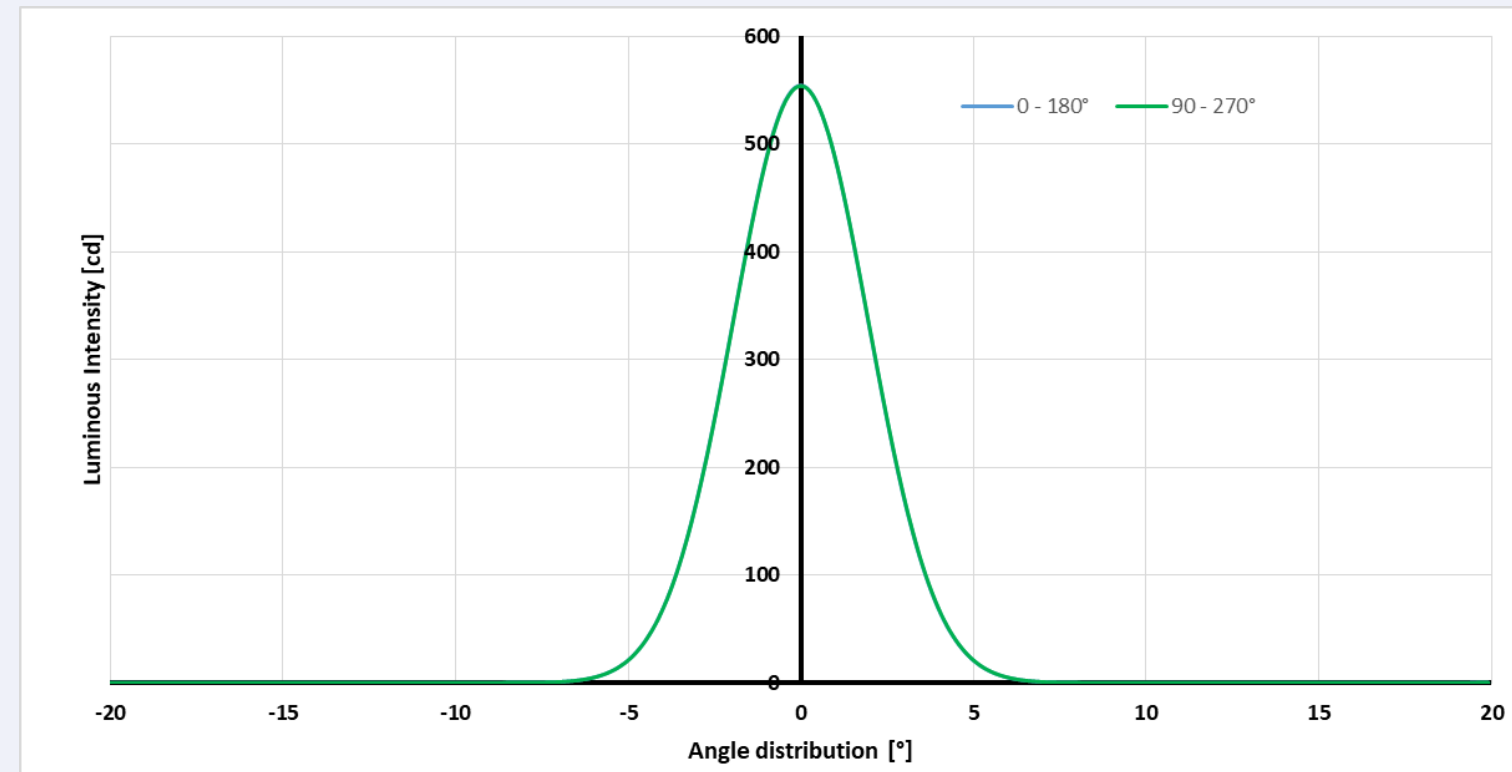

- Projection wall 3x3 m at 1m

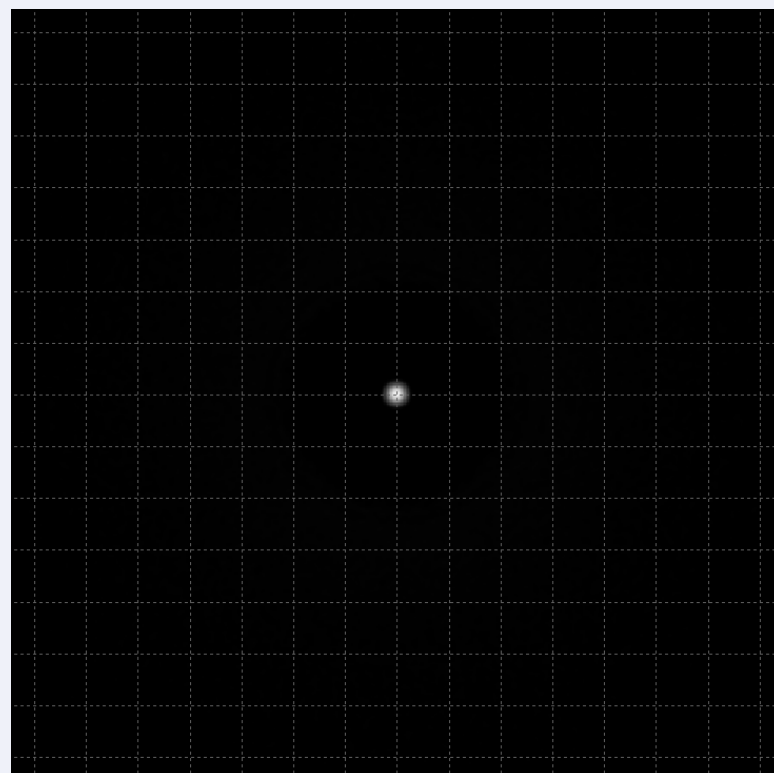

LED used for simulation	Cree XP-G
Luminous flux of LED [lm]	36
FWHM Co [°]	5
FWHM C90 [°]	5

* The ratio between luminous flux on the projection wall (3x3 m at 1 m) and luminous flux of LED

A116 7727

REVISION HISTORY			
REV.	DESCRIPTION	DATE	APPROVED

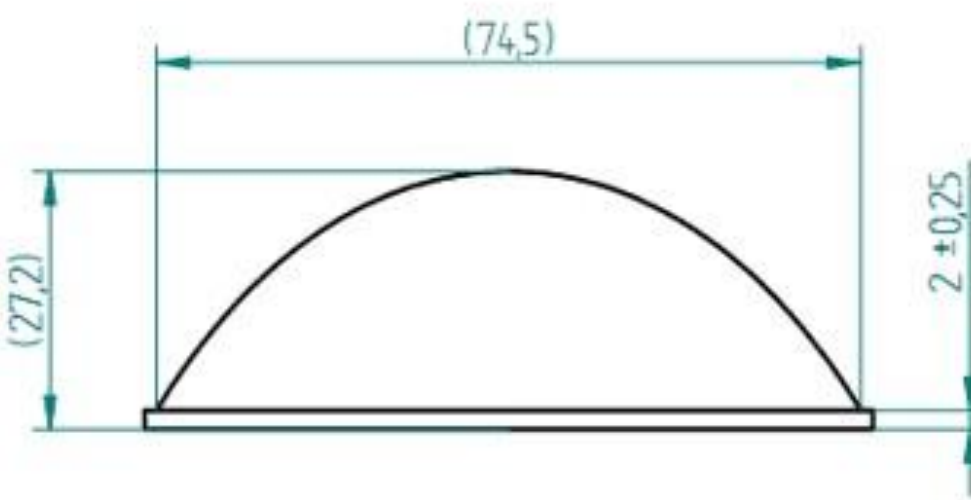
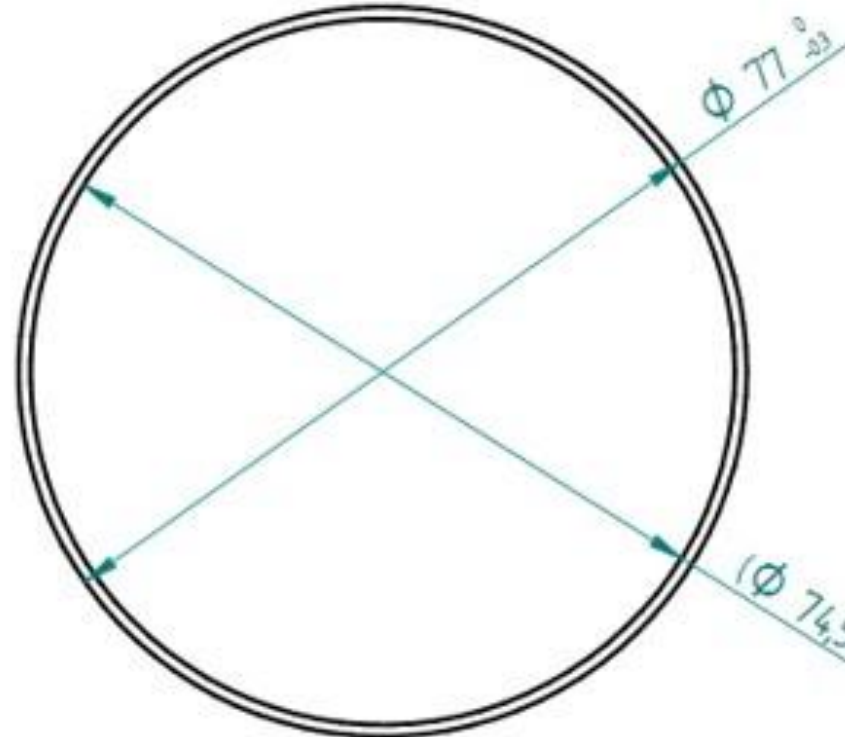



SCALE 1:2

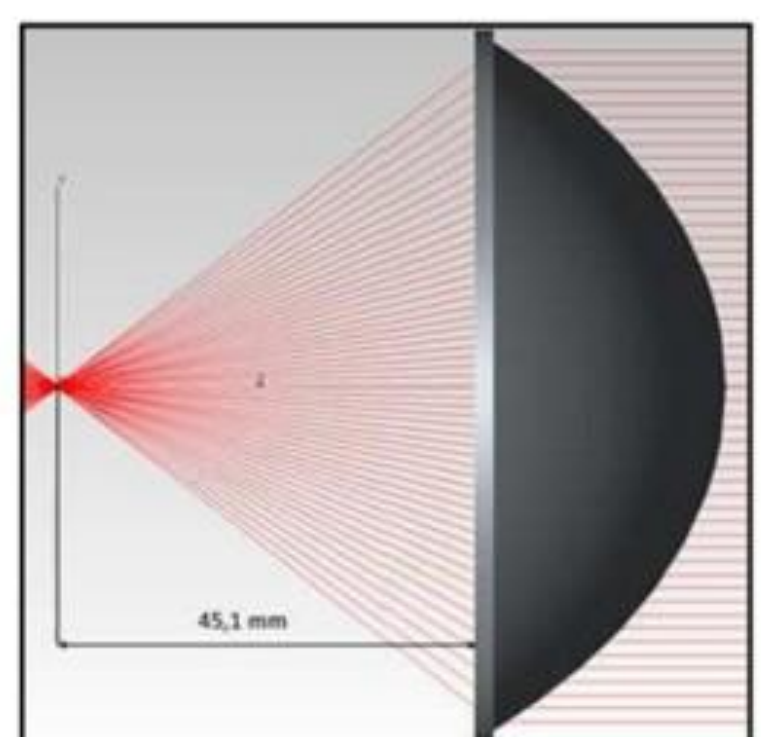

Glass: LIBA or alternative (nd = 1,521)



	NAME	DATE	 <p>A116 7727</p>															
DRAWN	kr/ky	05/14/20																
CHECKED																		
ENG APPR																		
MGR APPR																		
UNLESS OTHERWISE SPECIFIED DIMENSIONS ARE IN MILLIMETERS			<table border="1" style="width: 100%; border-collapse: collapse;"> <tr> <td style="font-size: x-small;">SIZE</td> <td style="font-size: x-small;">DWG NO</td> <td style="font-size: x-small;">REV</td> </tr> <tr> <td style="font-size: x-small;">44</td> <td></td> <td></td> </tr> <tr> <td colspan="3" style="font-size: x-small;">FILE NAME: A116_LensL1.dwg</td> </tr> <tr> <td style="font-size: x-small;">SCALE</td> <td style="font-size: x-small;">WEIGHT</td> <td style="font-size: x-small;">SHEET 1 OF 1</td> </tr> <tr> <td></td> <td>174 g</td> <td></td> </tr> </table>	SIZE	DWG NO	REV	44			FILE NAME: A116_LensL1.dwg			SCALE	WEIGHT	SHEET 1 OF 1		174 g	
SIZE	DWG NO	REV																
44																		
FILE NAME: A116_LensL1.dwg																		
SCALE	WEIGHT	SHEET 1 OF 1																
	174 g																	

A116 7727 – simulation results

- Polar Candela Distribution Plot

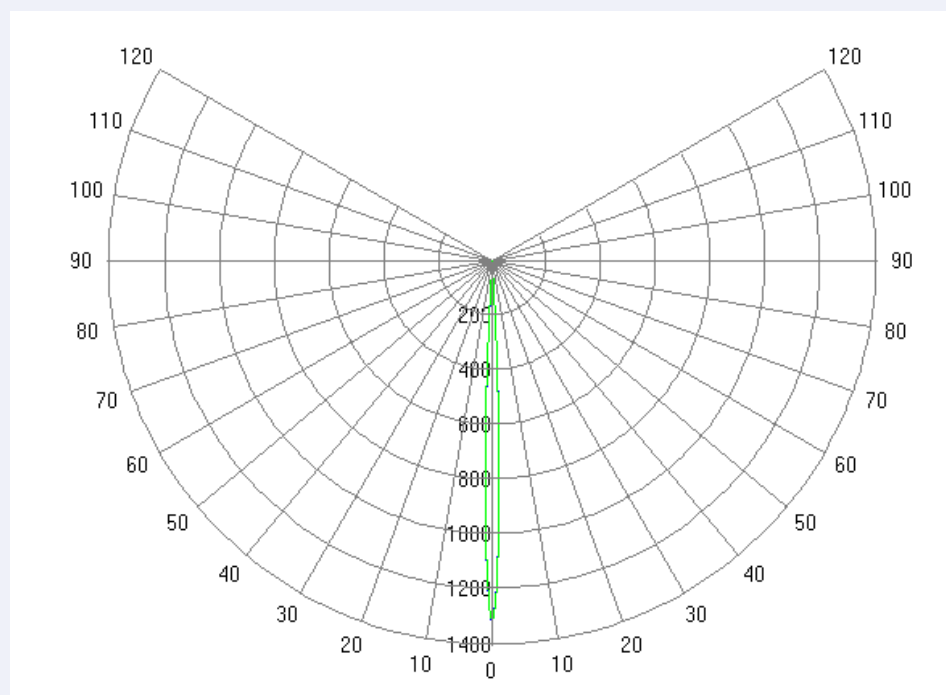

- Rectangular Candela Distribution Plot

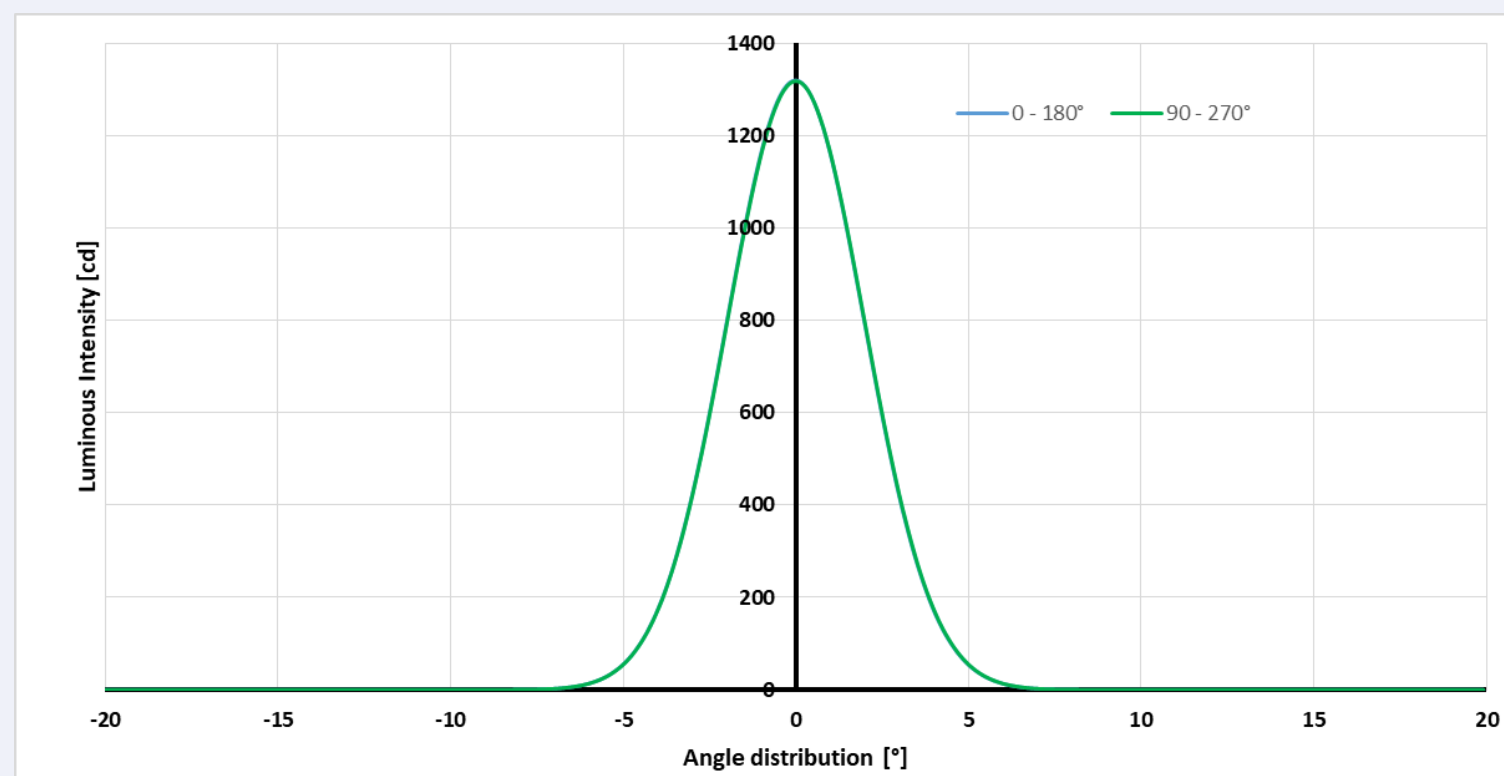

- Projection wall 3x3 m at 1m

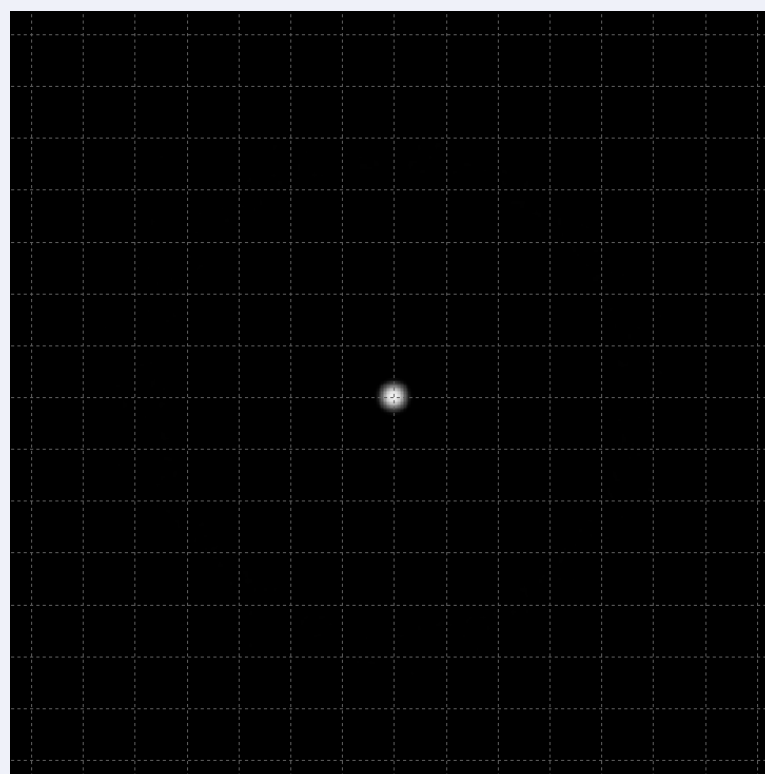

LED used for simulation	Cree XP-G
Luminous flux of LED [lm]	36
FWHM Co [°]	5
FWHM C90 [°]	5

* The ratio between luminous flux on the projection wall (3x3 m at 1 m) and luminous flux of LED

A132 6523

REVISION HISTORY			
REV	DESCRIPTION	DATE	APPROVED

Technical drawing of an aspheric lens. The side view shows a lens with a diameter of 61.3 mm and a thickness of 2.6 ± 0.2 mm. The top surface has a radius of curvature of R 0.55 mm and a central thickness of 22.5 mm. The bottom surface is flat with a diameter of 65 mm (tolerance 0 to -0.4 mm) and a chamfered edge with a 88-degree angle. The top view shows an outer diameter of 61.3 mm and an inner diameter of 65 mm (tolerance 0 to -0.4 mm).

Ray diagram illustrating the optical properties of the lens. Parallel light rays from the left converge to a focal point at a distance of 38.6 mm from the lens. The lens is shown as a semi-circular shape with a flat back surface.

material : GLASS nd=1,520

DRAWN	jkocarek	DATE	06/10/25		TITLE	
CHECKED					Aspheric Lens	
ENG APPR					SIZE	A4
MGR APPR					DWG NO	A132 6523
UNLESS OTHERWISE SPECIFIED DIMENSIONS ARE IN MILLIMETERS				FILE NAME:	A132 6523 rekonstrukce z vykresuřt	
SCALE:		WEIGHT:		SHEET 1 OF 1		

A132 6523 – simulation results

- Polar Candela Distribution Plot

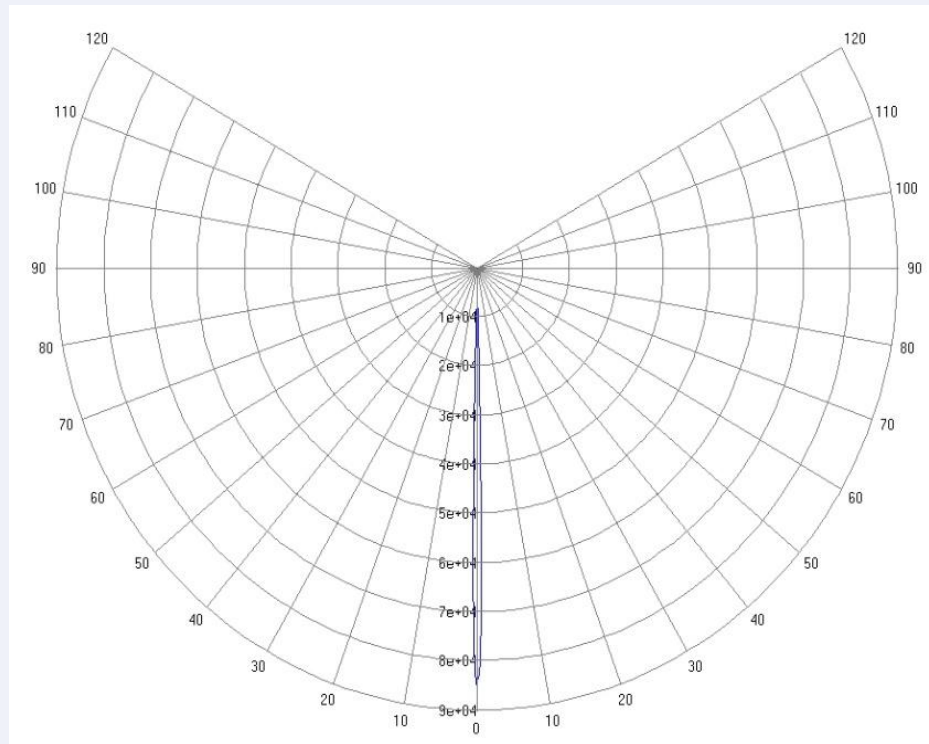

- Rectangular Candela Distribution Plot

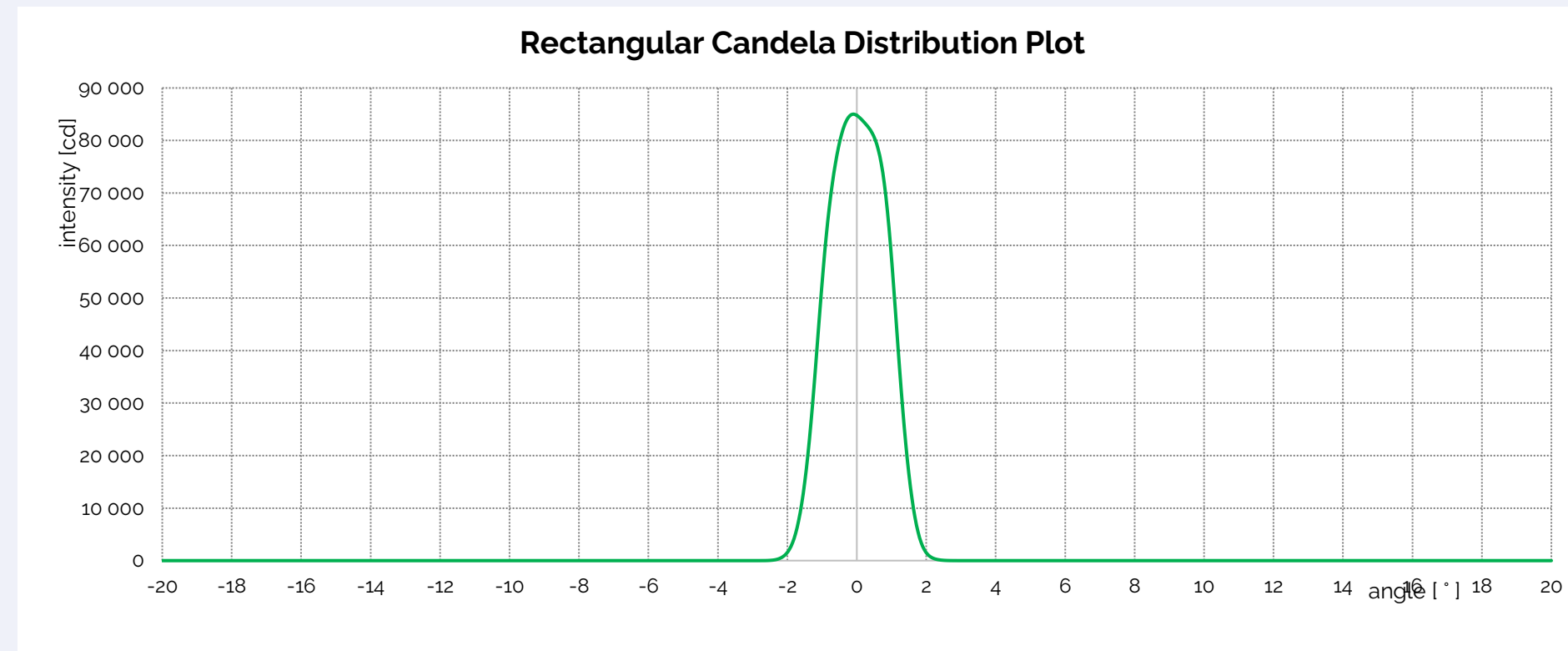

- Projection wall 3x3 m at 1m

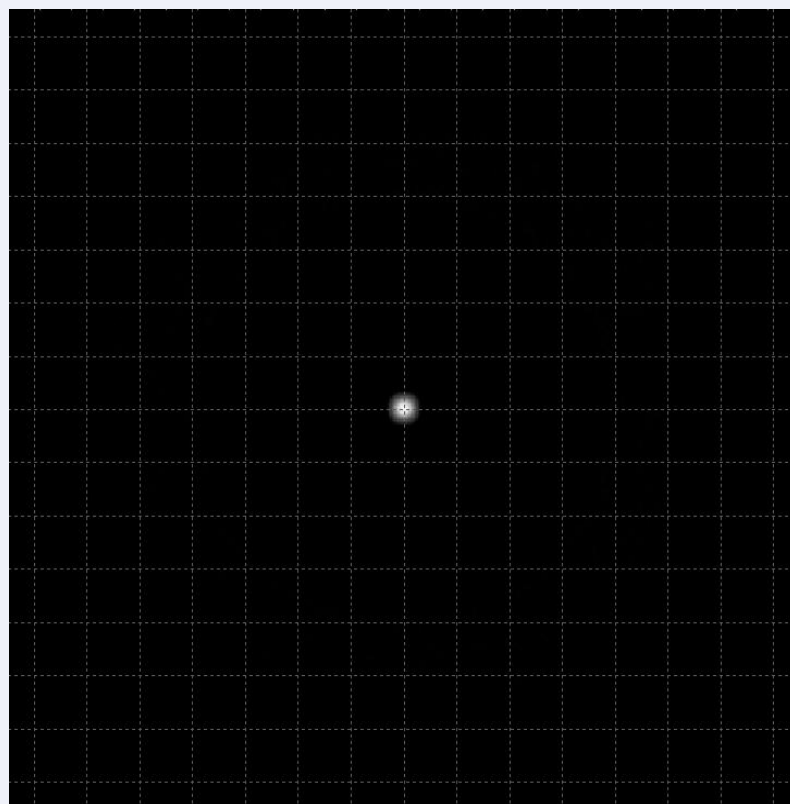

LED used for simulation	Cree XP-G4
Luminous flux of LED [lm]	350
FWHM Co [°]	2,5
FWHM C180 [°]	2,5

A163 6827

REVISION HISTORY			
REV	DESCRIPTION	DATE	APPROVED

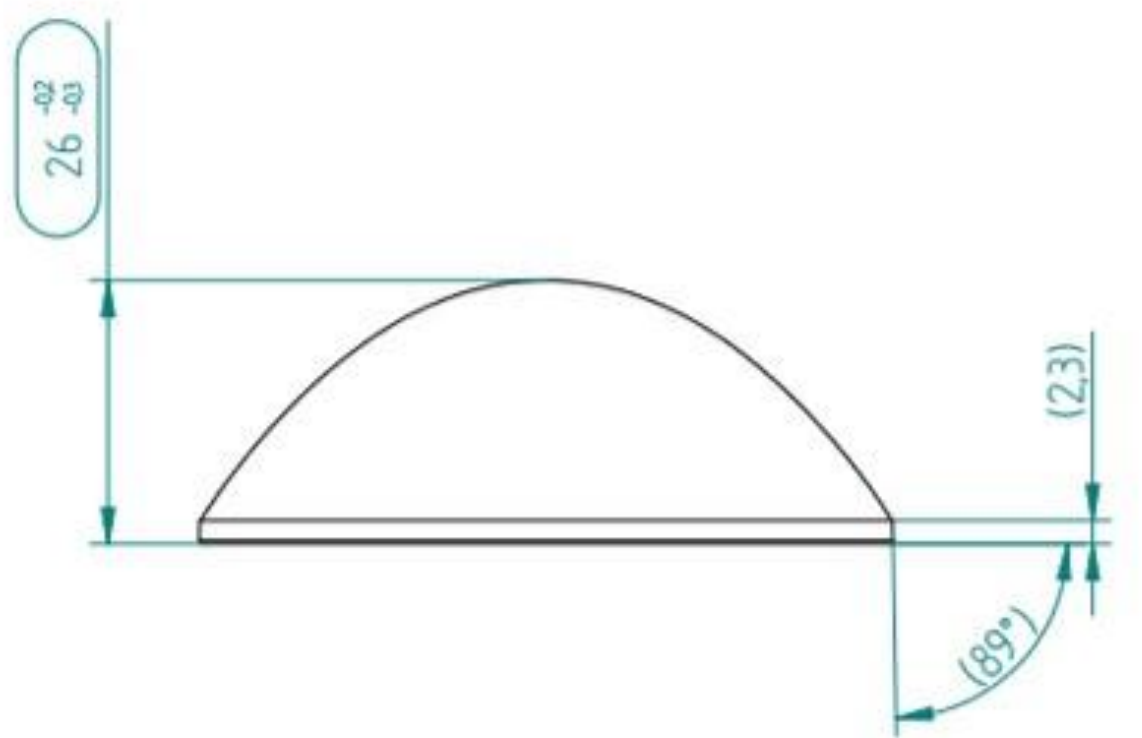

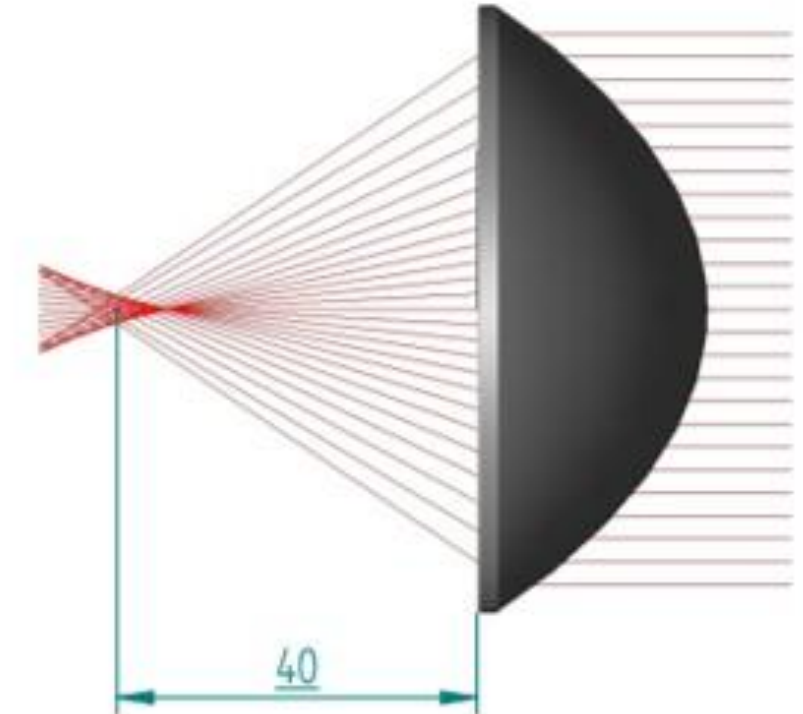

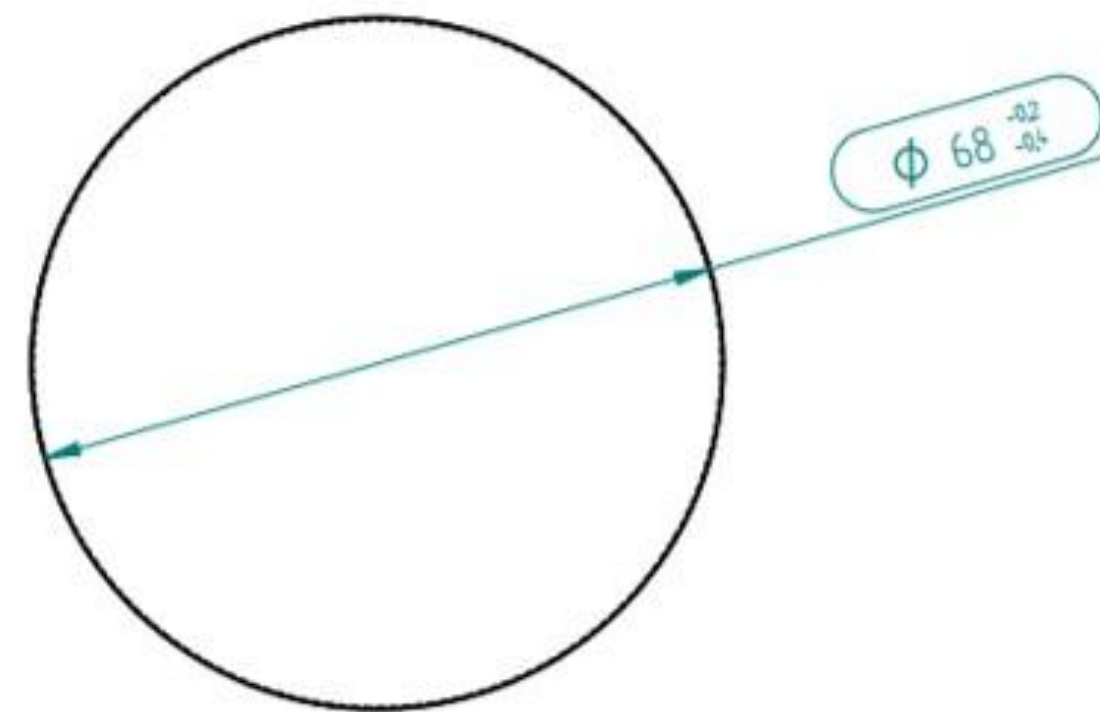

material : GLASS nd = 1,520

DRAWN	NAME	DATE		
CHECKED	jkocarek	09/14/23		
ENG APPR				
MGR APPR				
<small>UNLESS OTHERWISE SPECIFIED DIMENSIONS ARE IN MILLIMETERS ANGLES ±XX° 2 PL ±X.XX 3 PL ±X.XXX</small>			TITLE	Aspheric lens
SIZE	DWG NO	REV		
A4	A163 6827			
FILE NAME: A163 6827.dft				
SCALE:	WEIGHT:	SHEET 1 OF 1		

A163 6827 – simulation results

- Polar Candela Distribution Plot

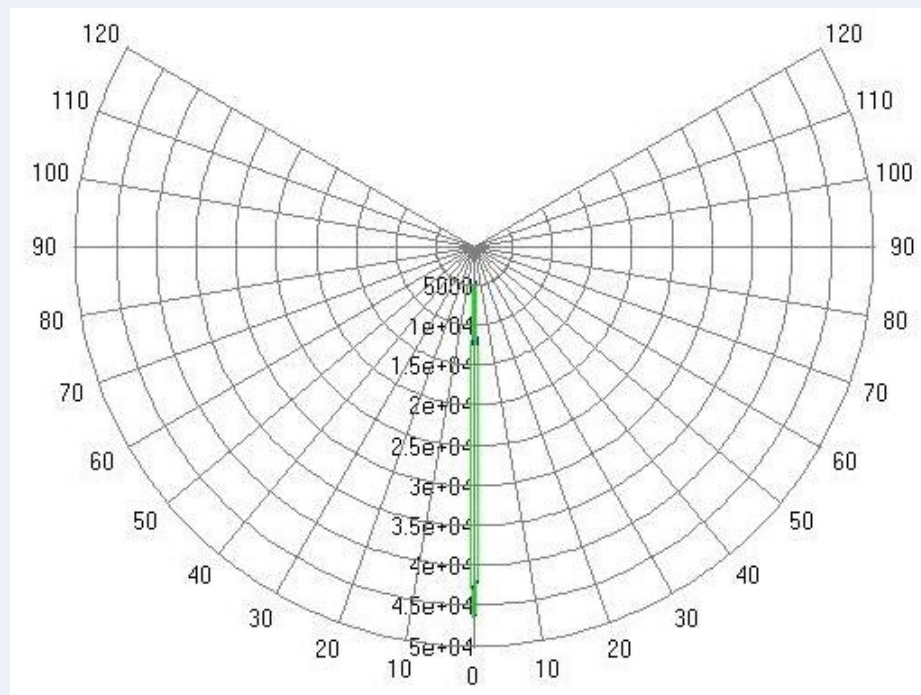

- Rectangular Candela Distribution Plot

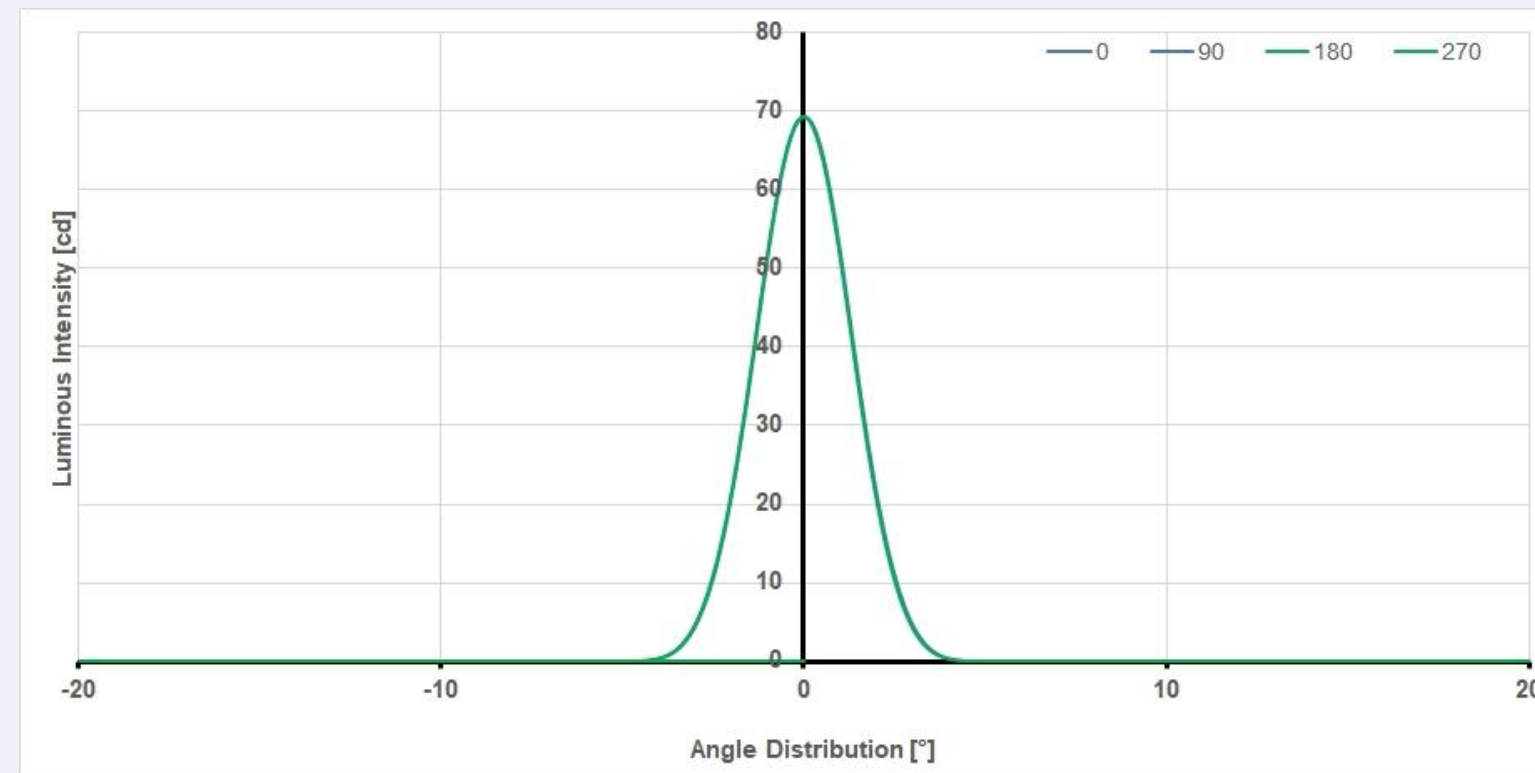

- Projection wall 3x3 m at 1m

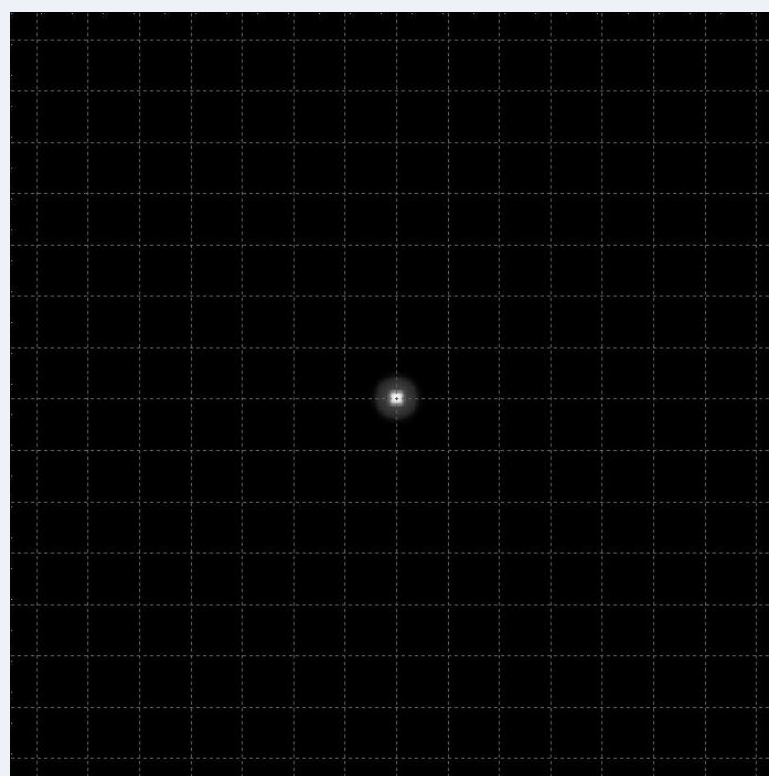

LED used for simulation	XP-G4
Luminous flux of LED [lm]	357
FWHM Co [°]	3
FWHM C90 [°]	3

* The ratio between luminous flux on the projection wall (3x3 m at 1 m) and luminous flux of LED

A175 6419

REVISION HISTORY			
REV	DESCRIPTION	DATE	APPROVED

Side view dimensions: $214 \pm 0,2$, $3 \pm 0,2$, $64^{+0,4}_0$

Top view dimensions: $\phi 64^{+0,4}_0$, $\phi 60$, $\phi 61,2$, $(R 3,2)$, (8°)

Ray diagram focal length: 40

material : GLASS nd=1,520

DRAWN	jkocarek	DATE	06/11/25	<p>ECOGLASS</p> <p>TITLE Aspheric Lens Modulated</p>												
CHECKED																
ENG APPR																
MGR APPR																
UNLESS OTHERWISE SPECIFIED DIMENSIONS ARE IN MILLIMETERS				<table border="1" style="width: 100%; border-collapse: collapse;"> <tr> <td style="width: 10%;">SIZE</td> <td style="width: 40%;">DWG NO</td> <td style="width: 50%;">REV</td> </tr> <tr> <td>A4</td> <td>A175 6419</td> <td> </td> </tr> <tr> <td colspan="3">FILE NAME: A175 6419.dft</td> </tr> <tr> <td>SCALE:</td> <td>WEIGHT:</td> <td>SHEET 1 OF 1</td> </tr> </table>	SIZE	DWG NO	REV	A4	A175 6419		FILE NAME: A175 6419.dft			SCALE:	WEIGHT:	SHEET 1 OF 1
SIZE	DWG NO	REV														
A4	A175 6419															
FILE NAME: A175 6419.dft																
SCALE:	WEIGHT:	SHEET 1 OF 1														

A175 6419 – simulation results

- Polar Candela Distribution Plot

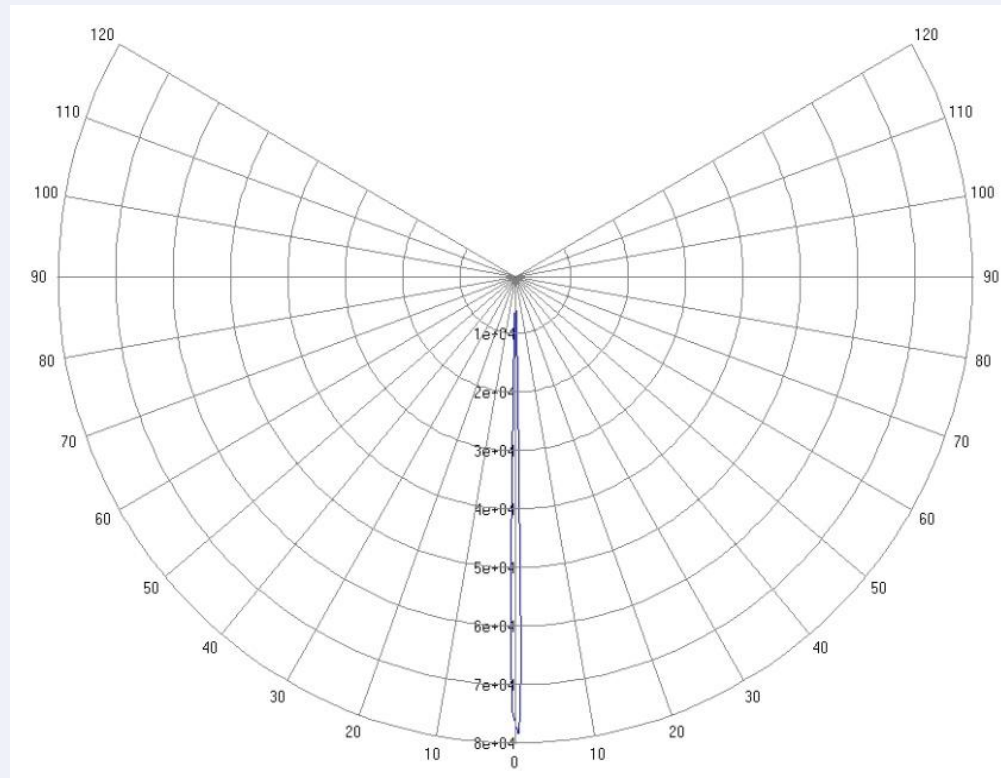

- Rectangular Candela Distribution Plot

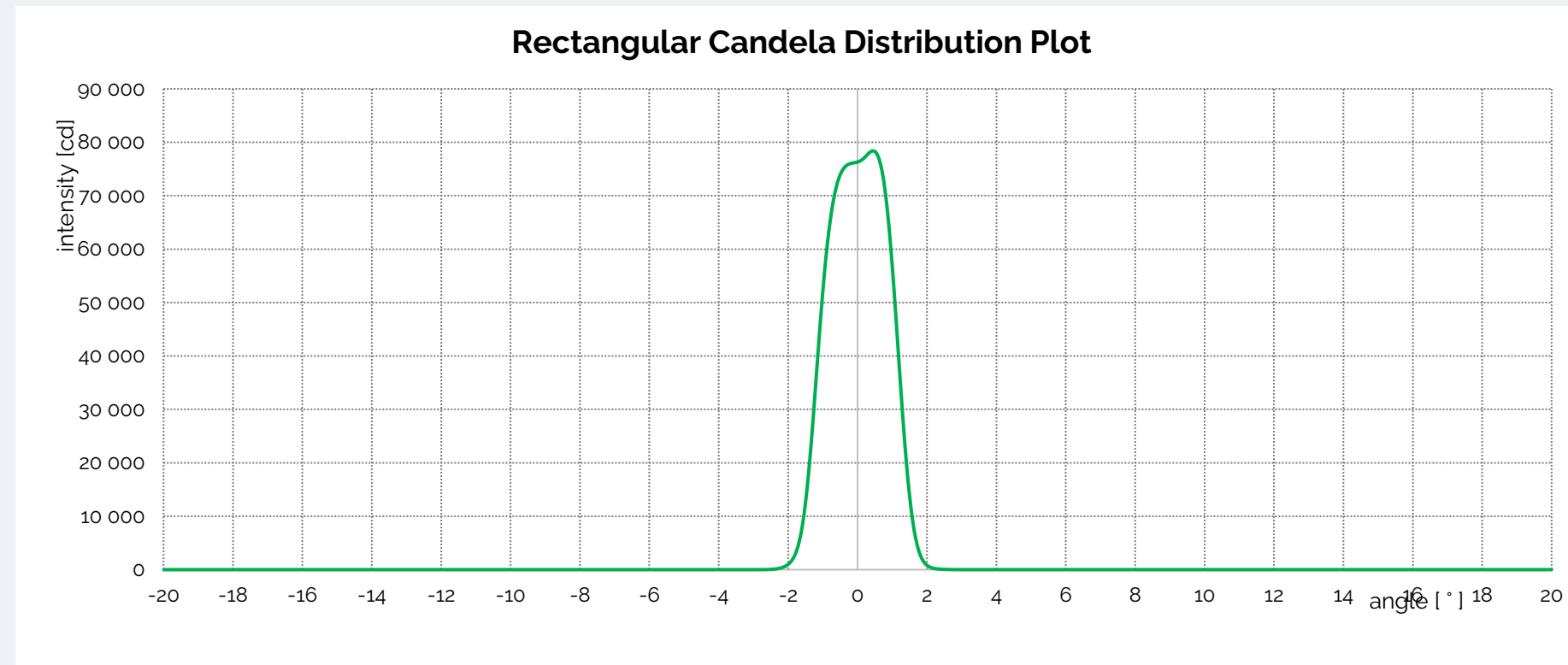

- Projection wall 3x3 m at 1m

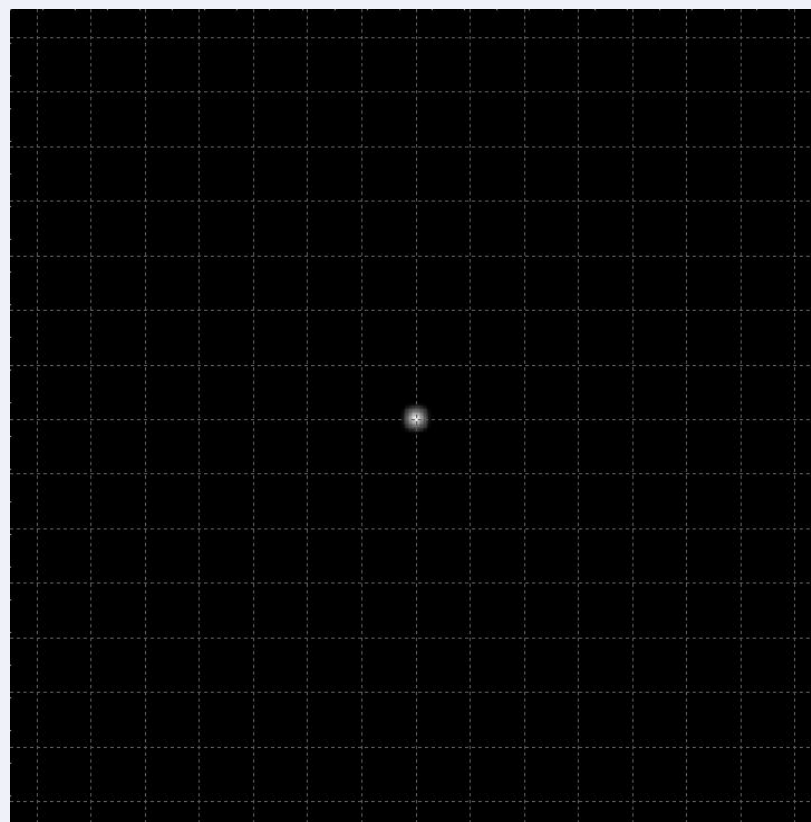

LED used for simulation	XP-G4
Luminous flux of LED [lm]	350
FWHM Co [°]	2,5
FWHM C180 [°]	2,5

A180 6016

REVISION HISTORY			
REV	DESCRIPTION	DATE	APPROVED

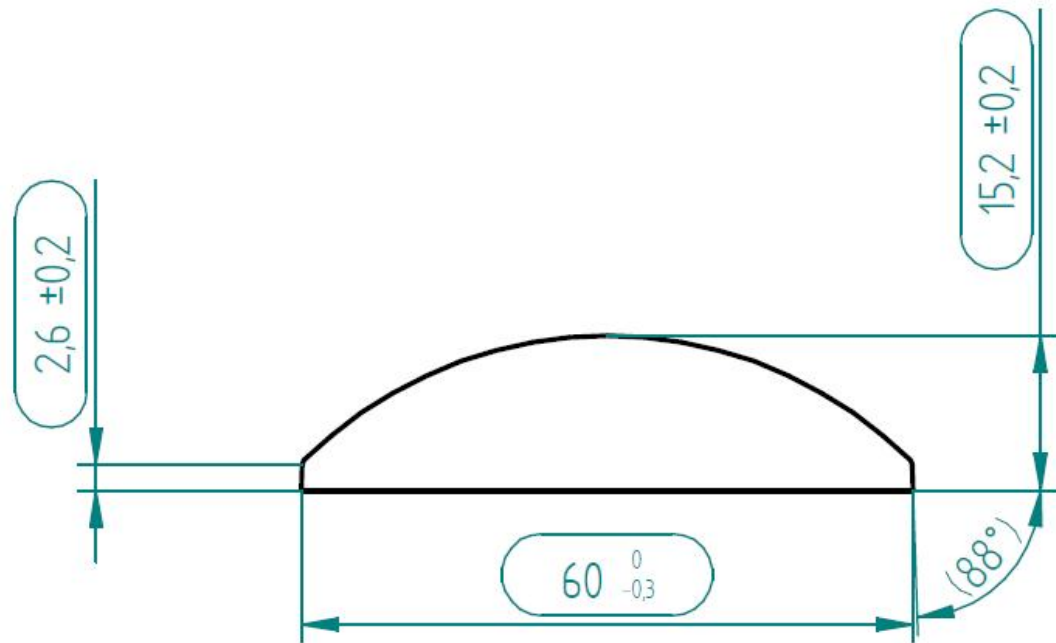

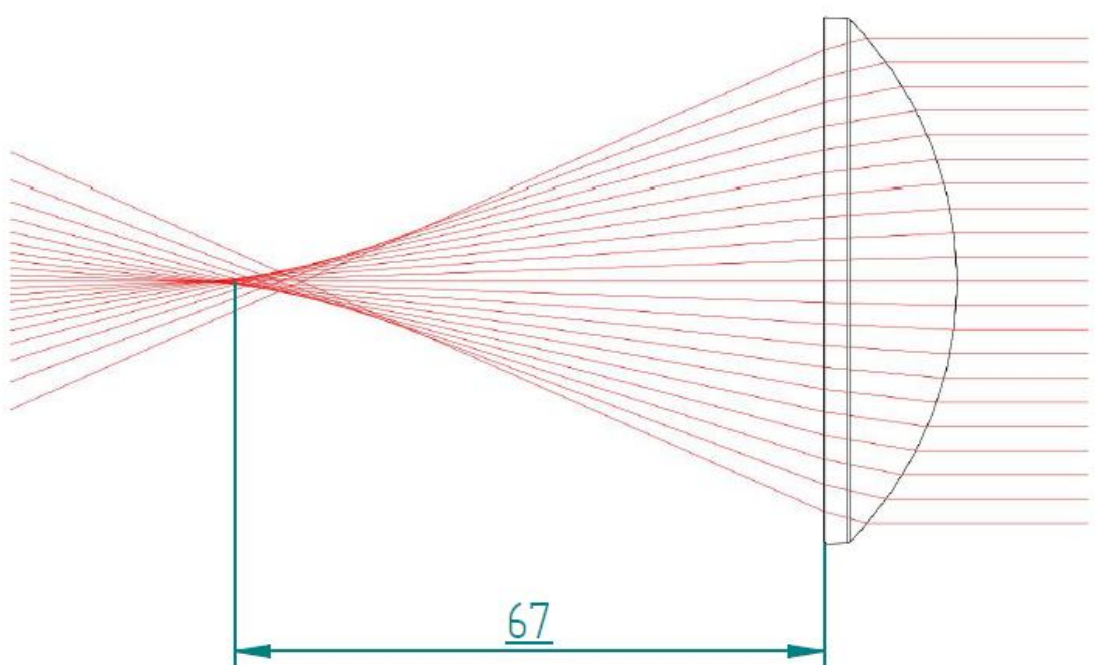

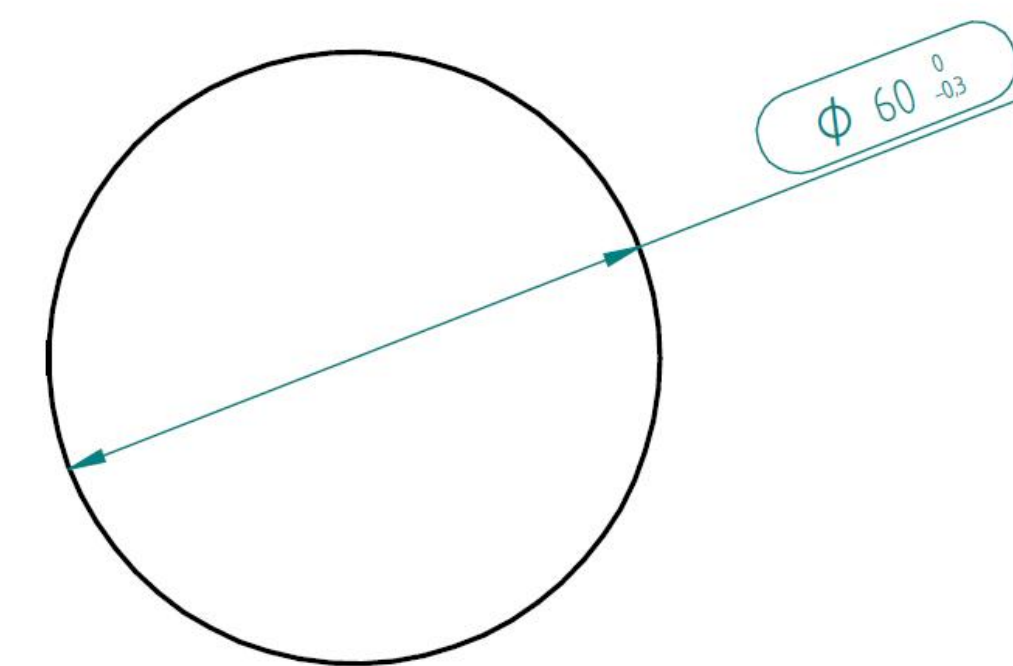



material : GLASS nd=1,520

DRAWN	jkocarek	DATE	06/10/25	
CHECKED				
ENG APPR				
MGR APPR				
UNLESS OTHERWISE SPECIFIED DIMENSIONS ARE IN MILLIMETERS				Spherical Lens
SIZE		DWG NO		REV
A4		A180 6016		
FILE NAME: A180 6016 rekonstrukce z vykresu.dft				
SCALE:		WEIGHT:		SHEET 1 OF 1

A180 6016 – simulation results

- Polar Candela Distribution Plot

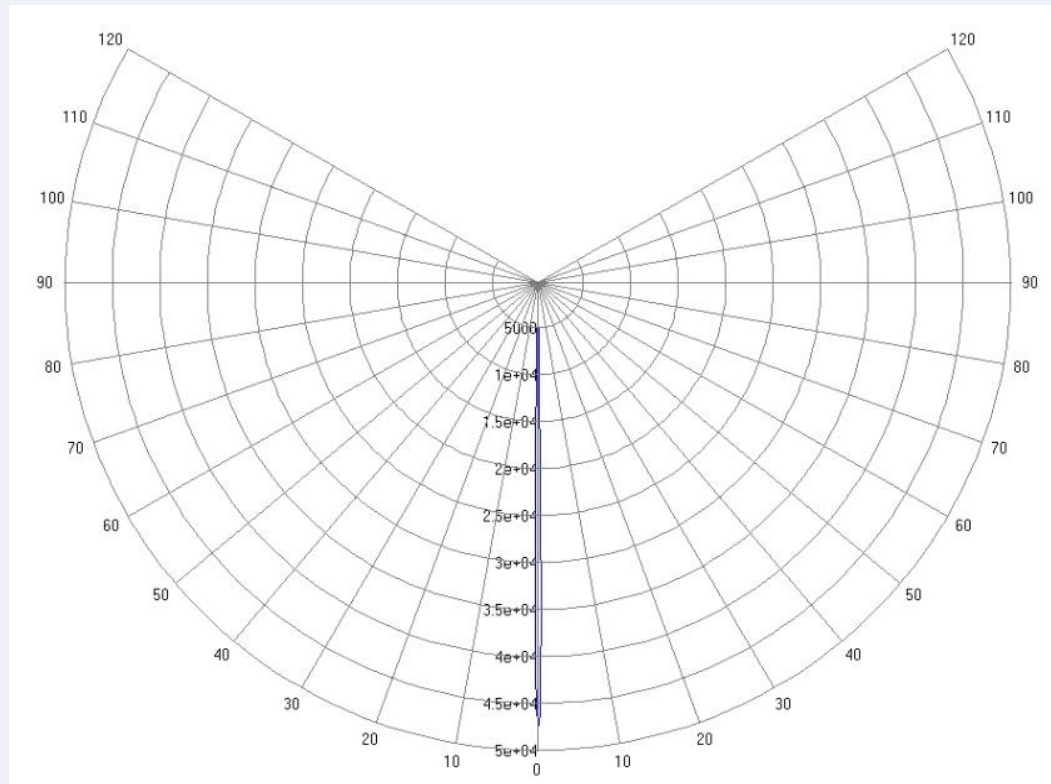

- Rectangular Candela Distribution Plot

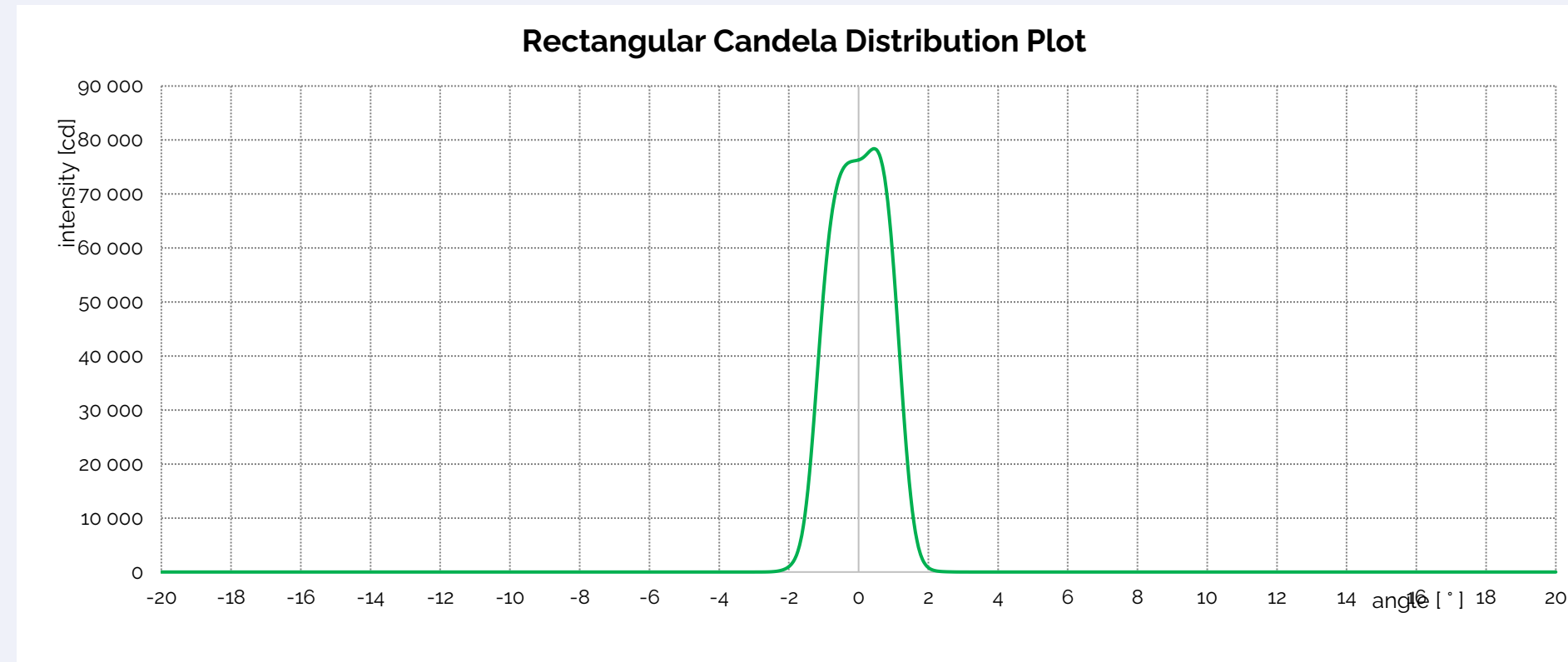

- Projection wall 3x3 m at 1m

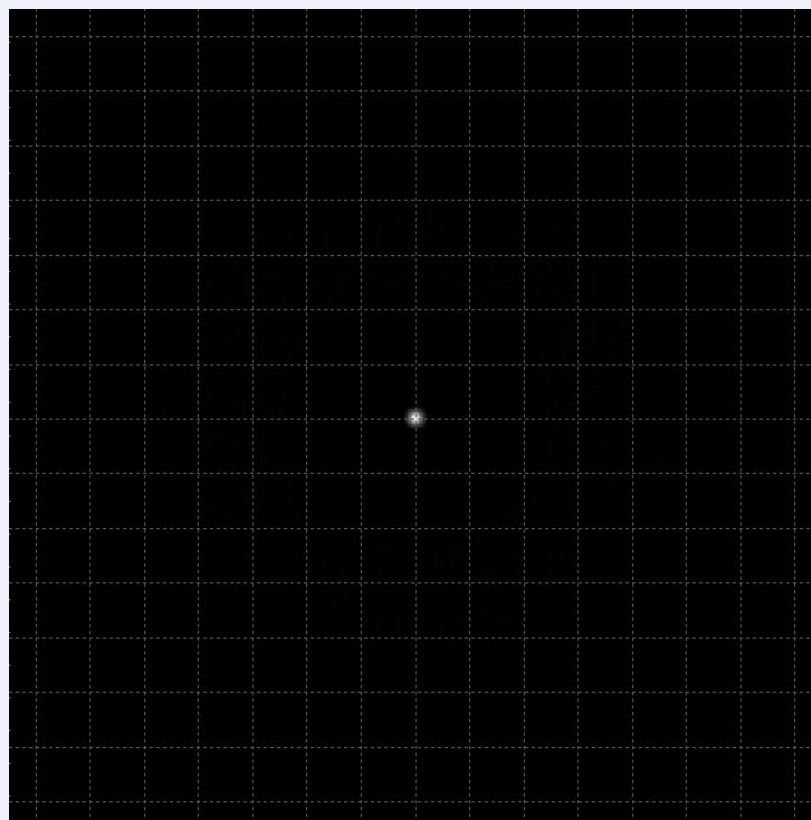

LED used for simulation	XP-G4
Luminous flux of LED [lm]	350
FWHM Co [°]	2,5
FWHM C180 [°]	2,5

A182 1506

REVISION HISTORY			
REV	DESCRIPTION	DATE	APPROVED

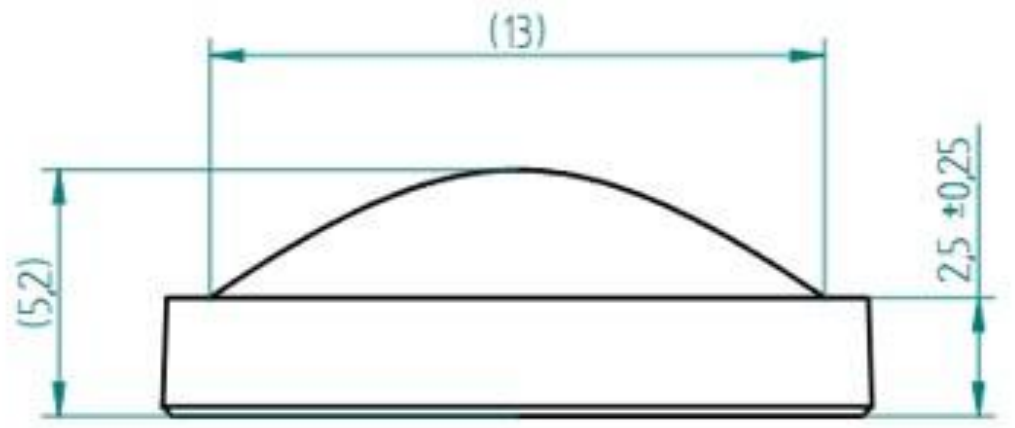
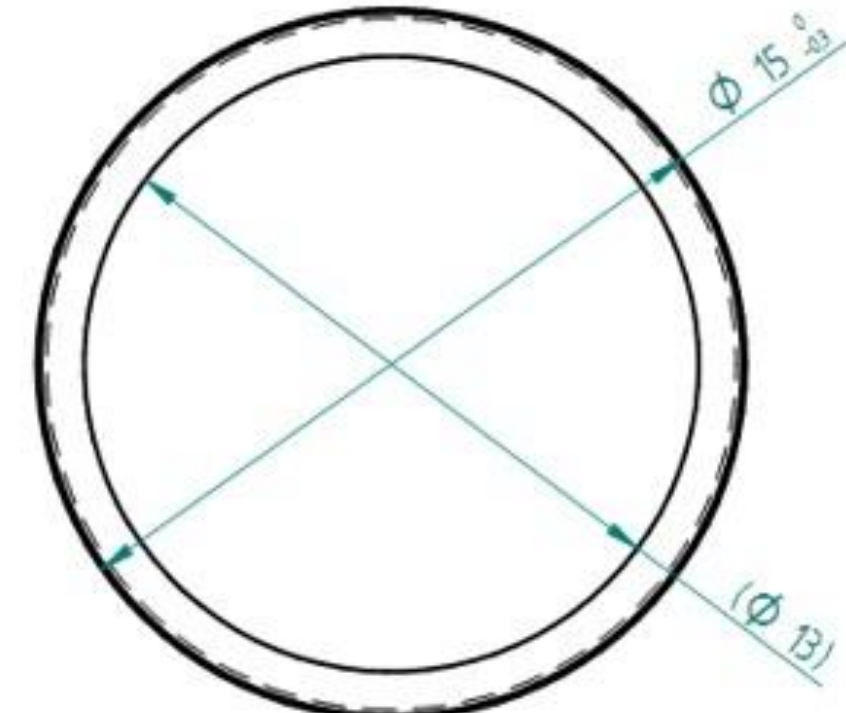
SCALE 2:1



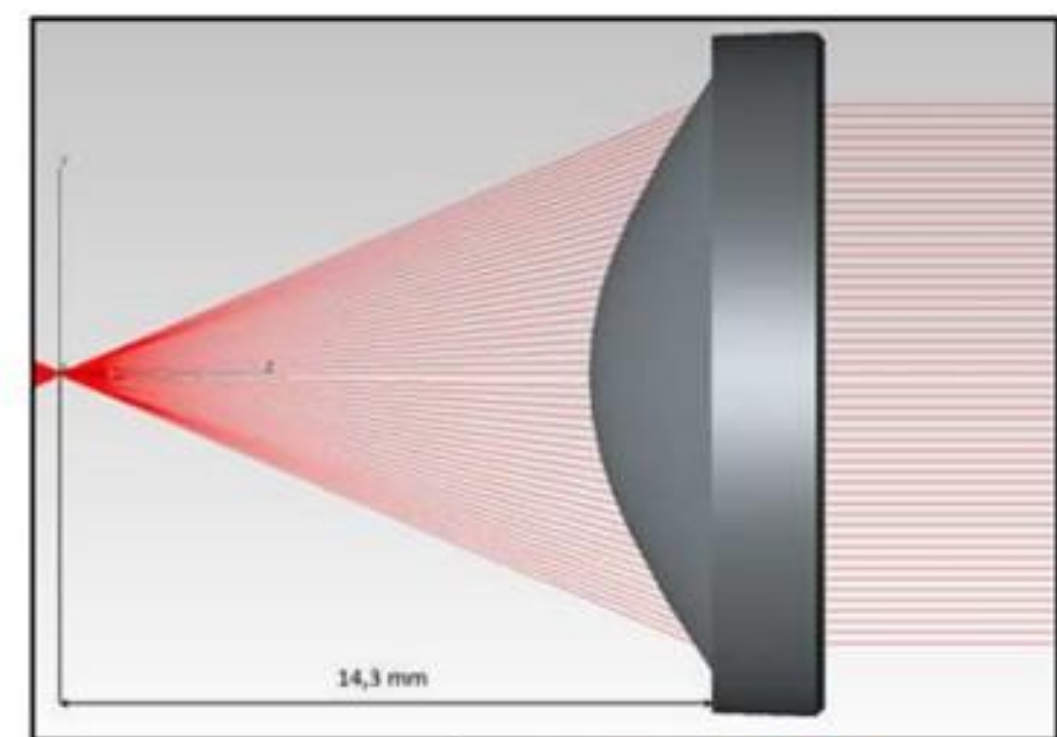

DRAW	NAME	DATE	 A182 1506
CHECKED			
ENG APPR			
MGR APPR			
UNLESS OTHERWISE SPECIFIED DIMENSIONS ARE IN MILLIMETERS			SIZE: 44 FILE NAME: A182_small.tif SCALE: WEIGHT: 2 g SHEET 1 OF 1

Glass: LIBA or alternative (nd = 1,521)

A182 1506 – simulation results

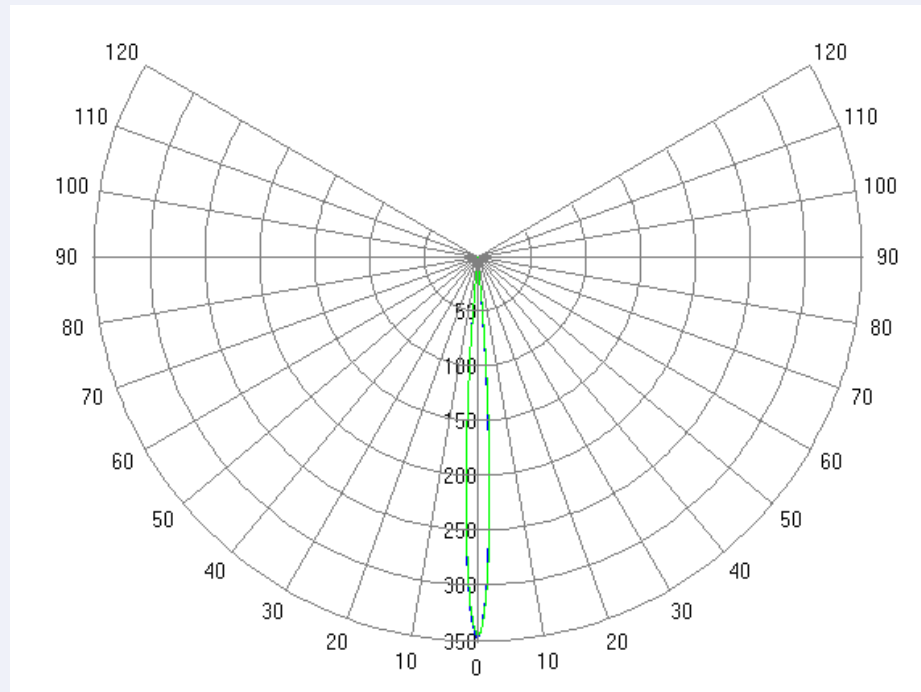
- Polar Candela Distribution Plot



- Rectangular Candela Distribution Plot

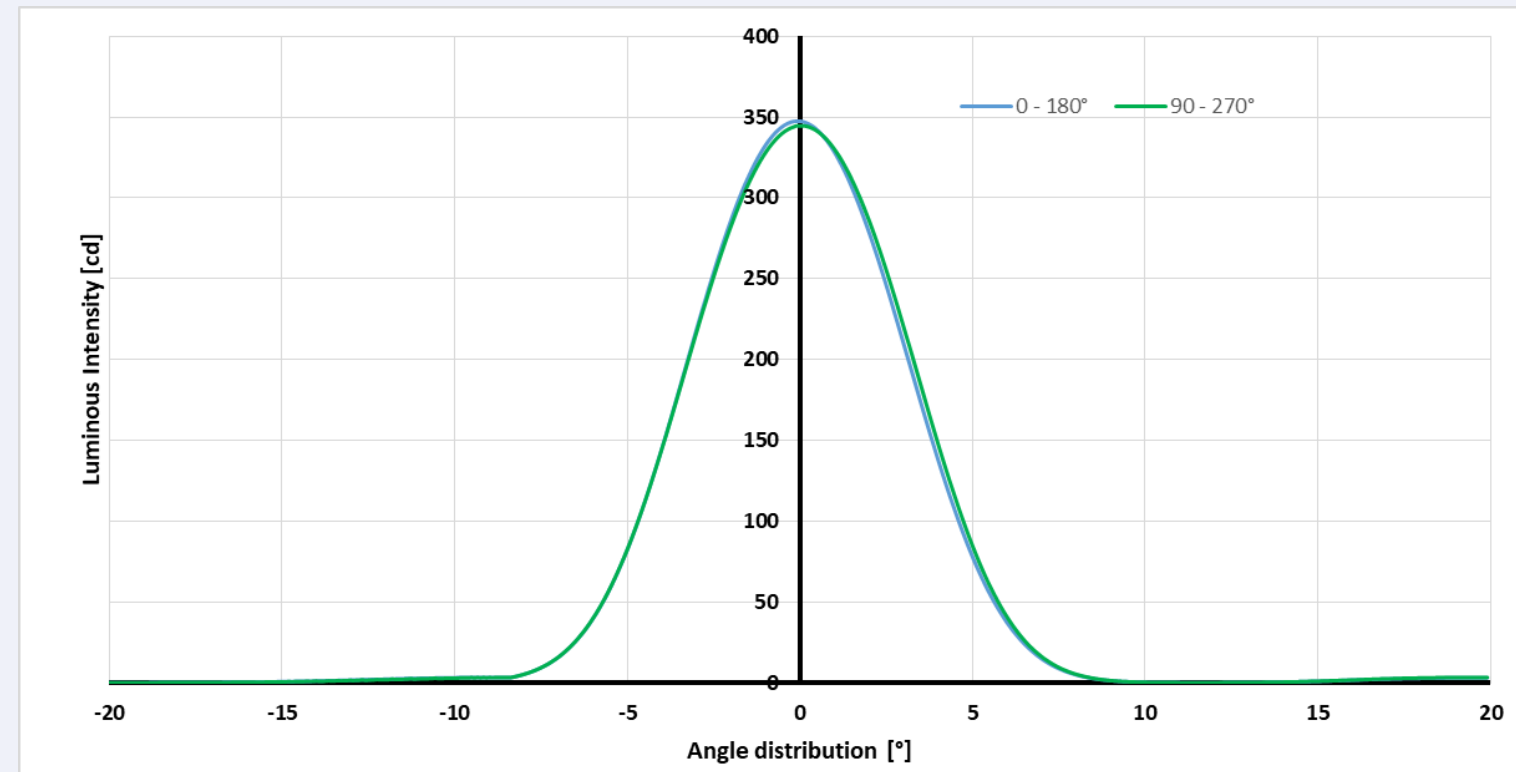

- Projection wall 3x3 m at 1m

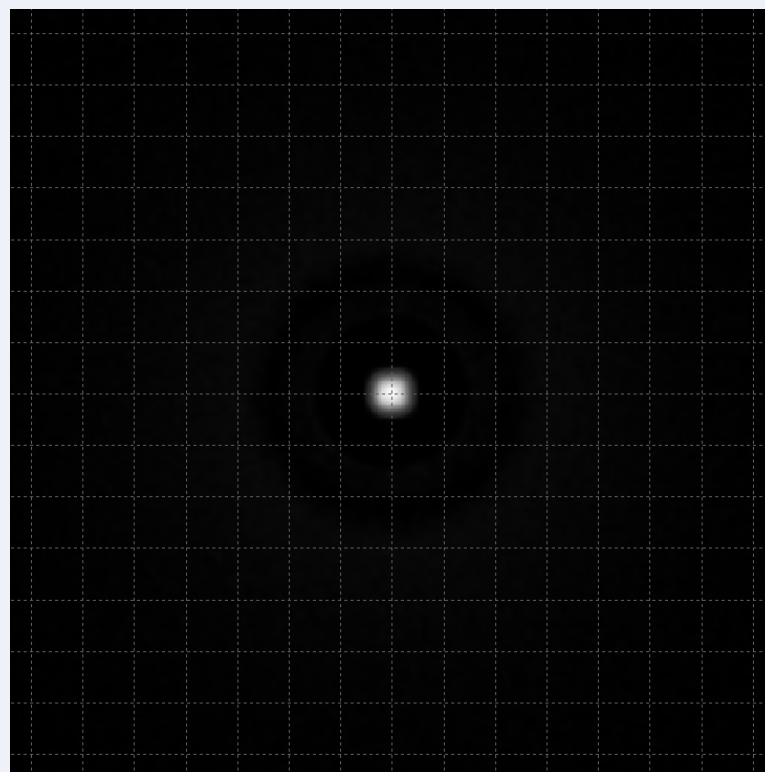

LED used for simulation	Cree XP-G
Luminous flux of LED [lm]	36
FWHM Co [°]	7
FWHM C90 [°]	7

* The ratio between luminous flux on the projection wall (3x3 m at 1 m) and luminous flux of LED

A194 1506

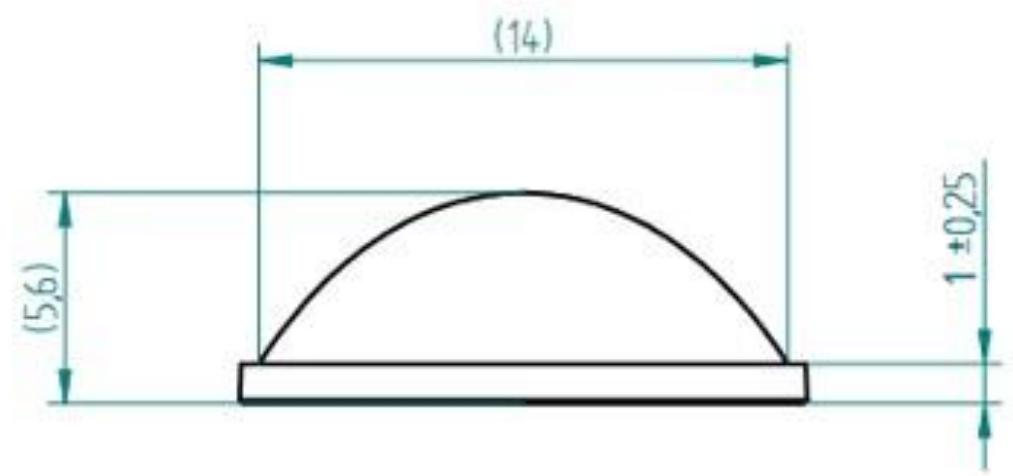
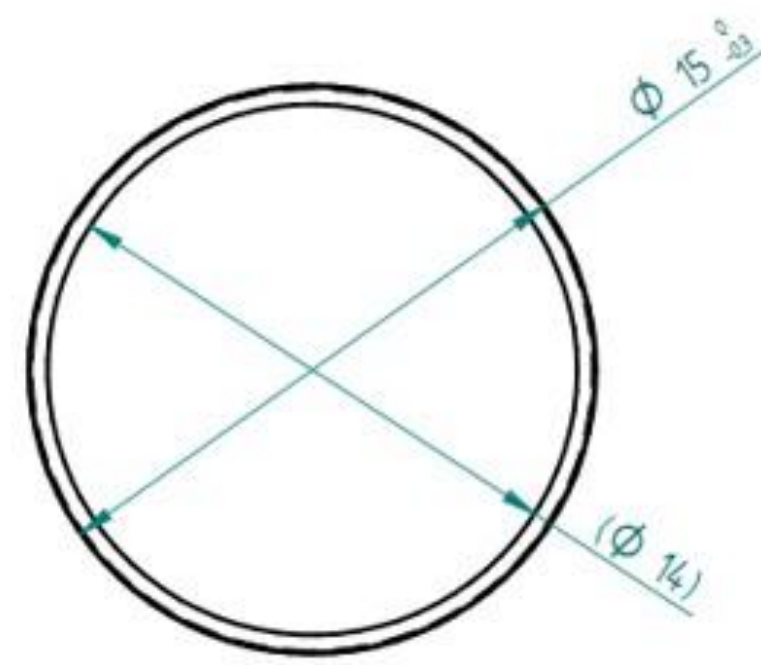
REVISION HISTORY

REV	DESCRIPTION	DATE	APPROVED

SCALE 2:1



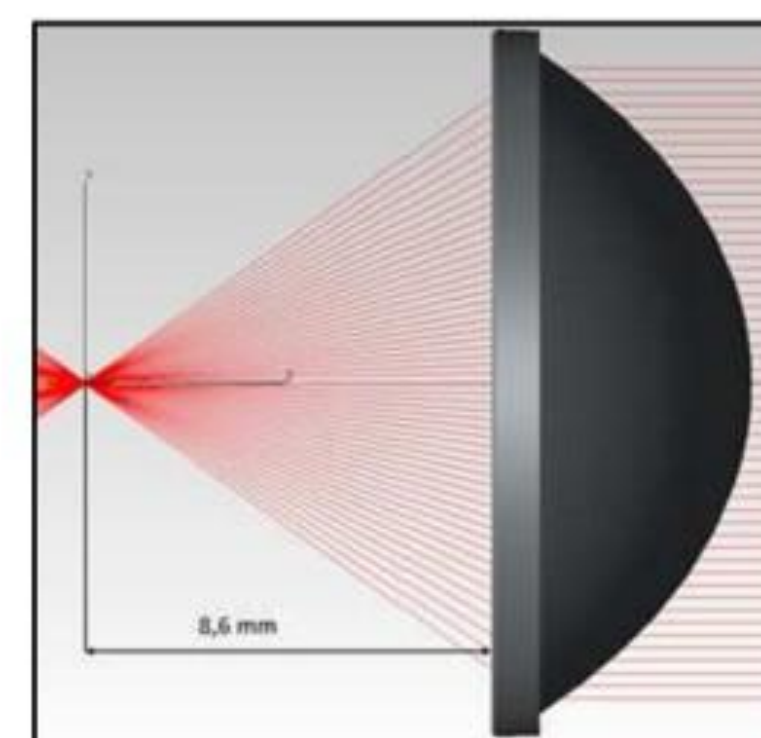

Glass: LIBA or alternative (nd = 1,521)

NAME	DATE	ECOGLOSS
Draw: <i>hry/hry</i>	05/14/20	 A194 1506
CHKD BY		
ENG APPR		
MGR APPR		
UNLESS OTHERWISE SPECIFIED DIMENSIONS ARE IN MILLIMETERS		SIZE: A4 FILE NAME: A194_1506.DWG SCALE: WEIGHT: 1g SHEET 1 OF 1

A194 1506 – simulation results

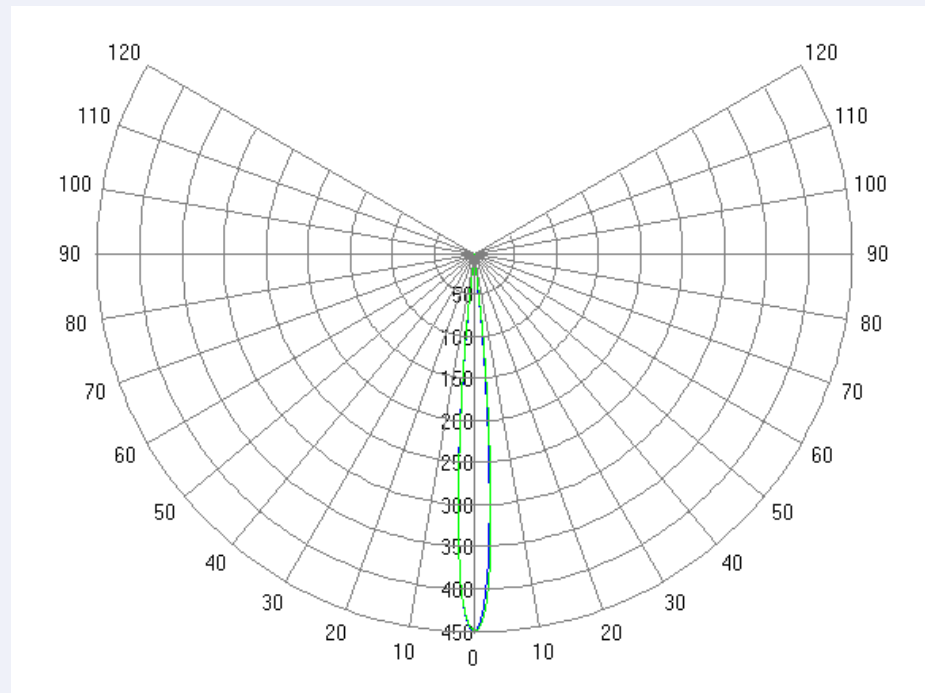
- Polar Candela Distribution Plot



- Rectangular Candela Distribution Plot

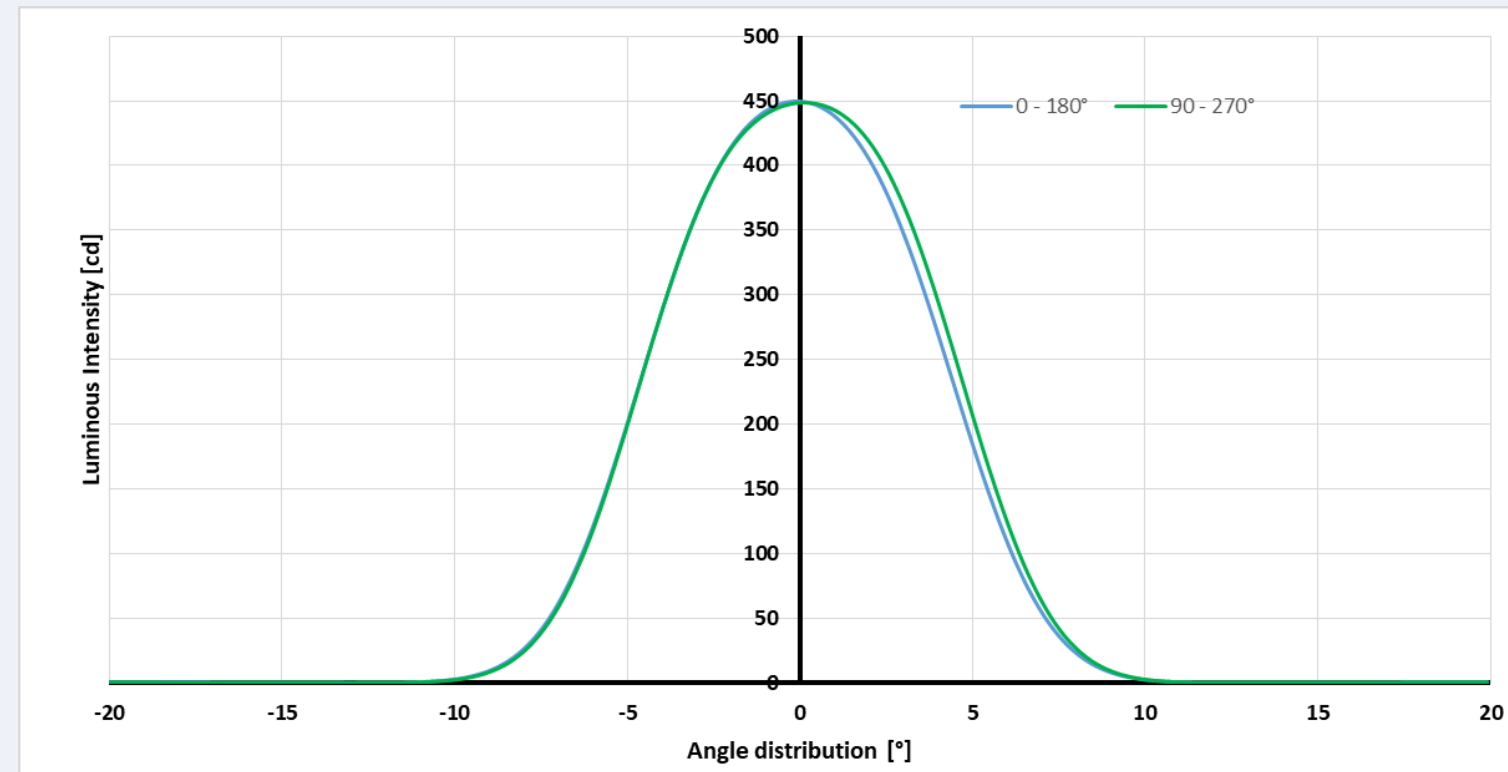

- Projection wall 3x3 m at 1m

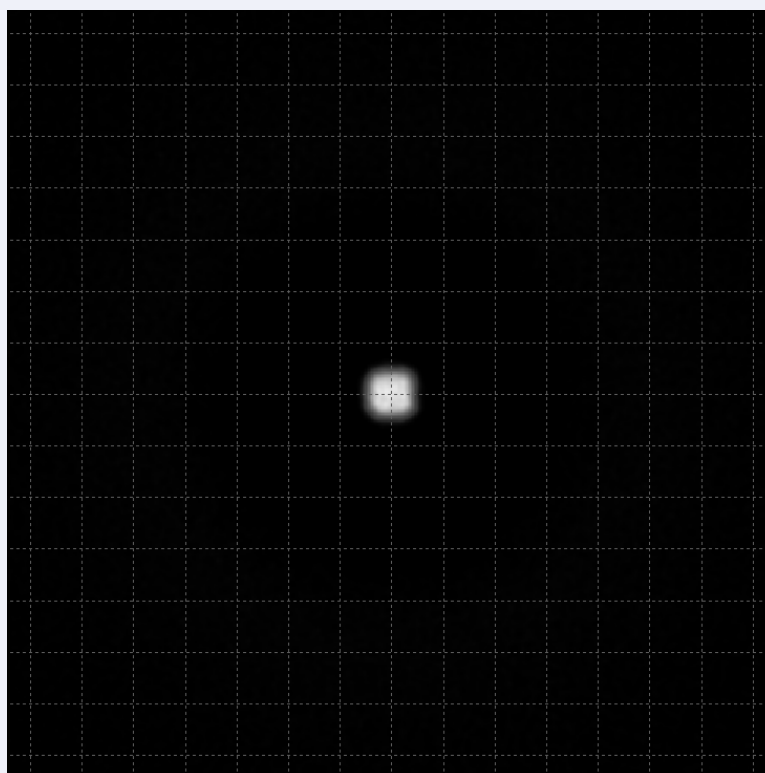

LED used for simulation	Cree XP-G
Luminous flux of LED [lm]	36
FWHM Co [°]	10
FWHM Cgo [°]	10

* The ratio between luminous flux on the projection wall (3x3 m at 1 m) and luminous flux of LED

A196 7120

REVISION HISTORY			
REV.	DESCRIPTION	DATE	APPROVED

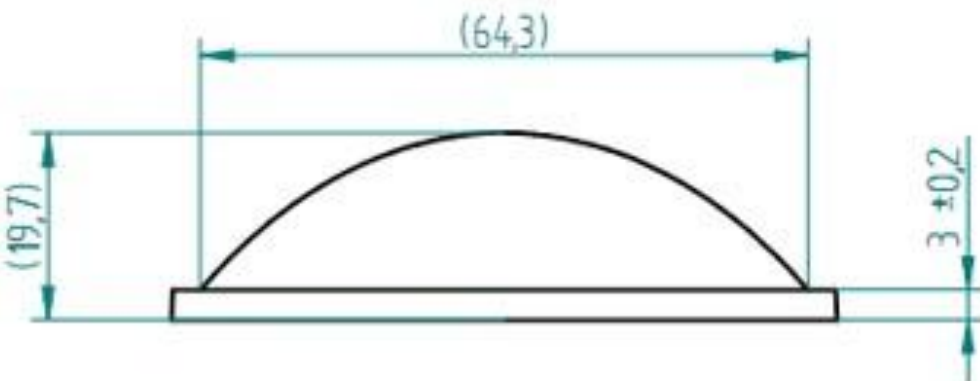

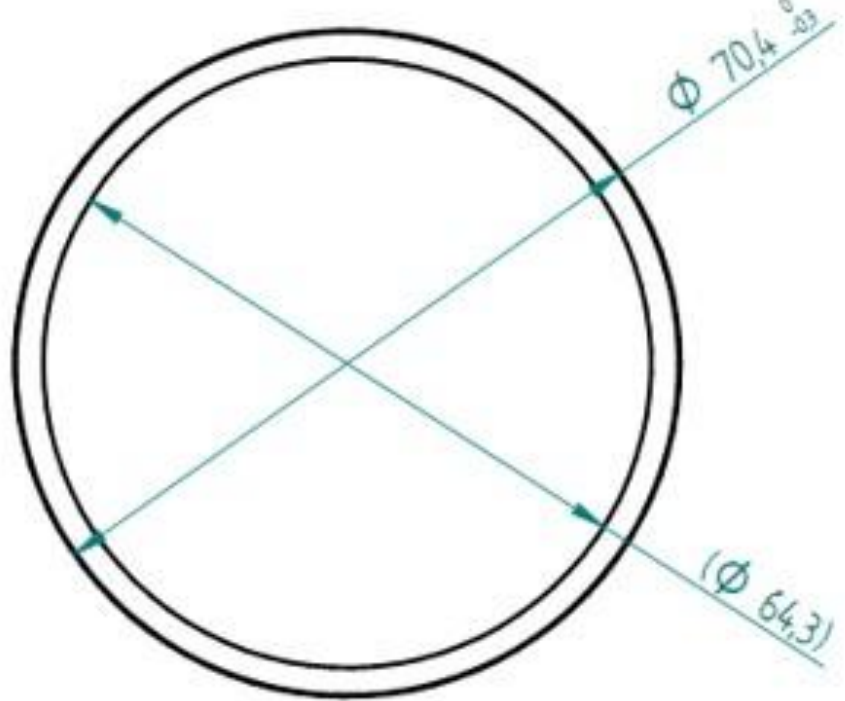



SCALE 1:2

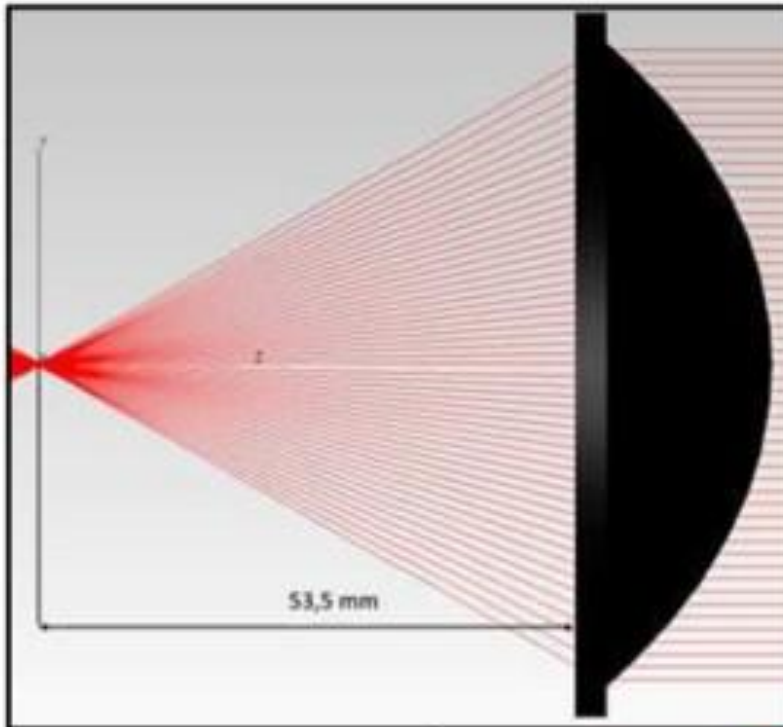

Glass: LIBA or alternative (nd = 1,521)



DRAW	NAME	DATE	 A196 7120
CHECKED			
ENG APPR			
MGR APPR			
UNLESS OTHERWISE SPECIFIED DIMENSIONS ARE IN MILLIMETERS			SIZE: 44 FILE NAME: A196_small.dwg SCALE: WEIGHT: 103 g SHEET 1 OF 1

A196 7120 – simulation results

- Polar Candela Distribution Plot

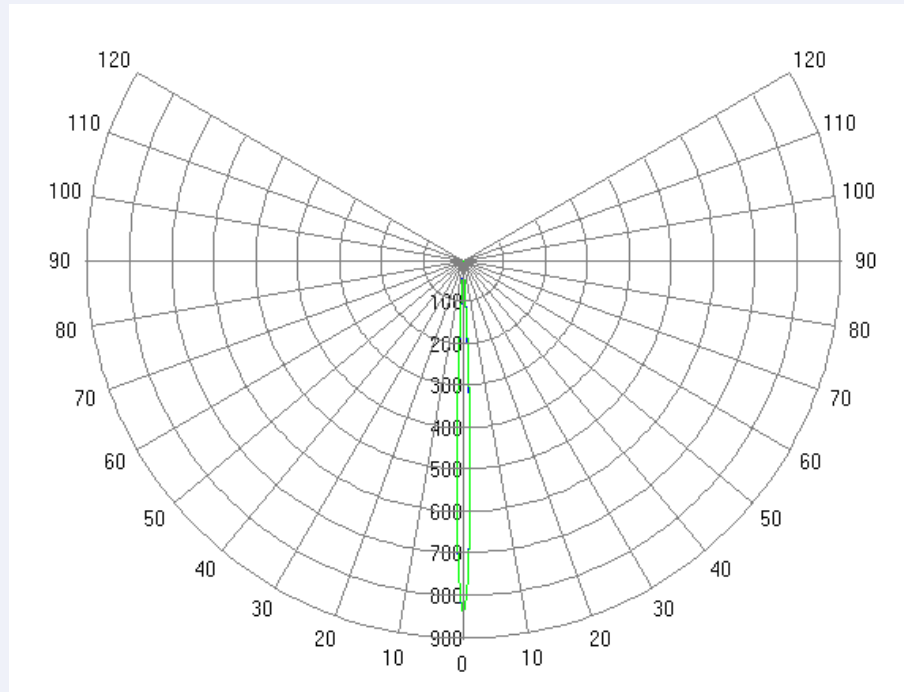

- Rectangular Candela Distribution Plot

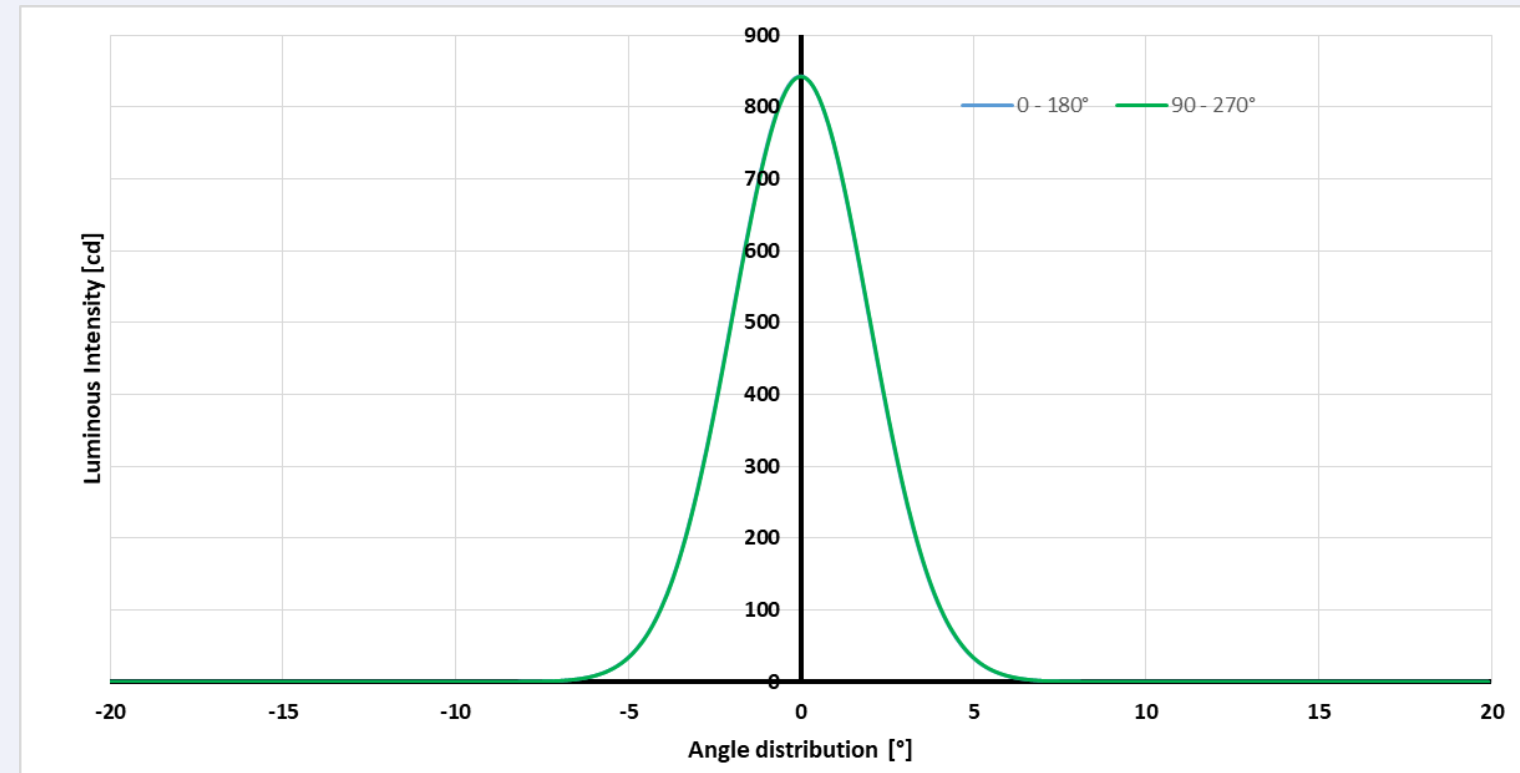

- Projection wall 3x3 m at 1m

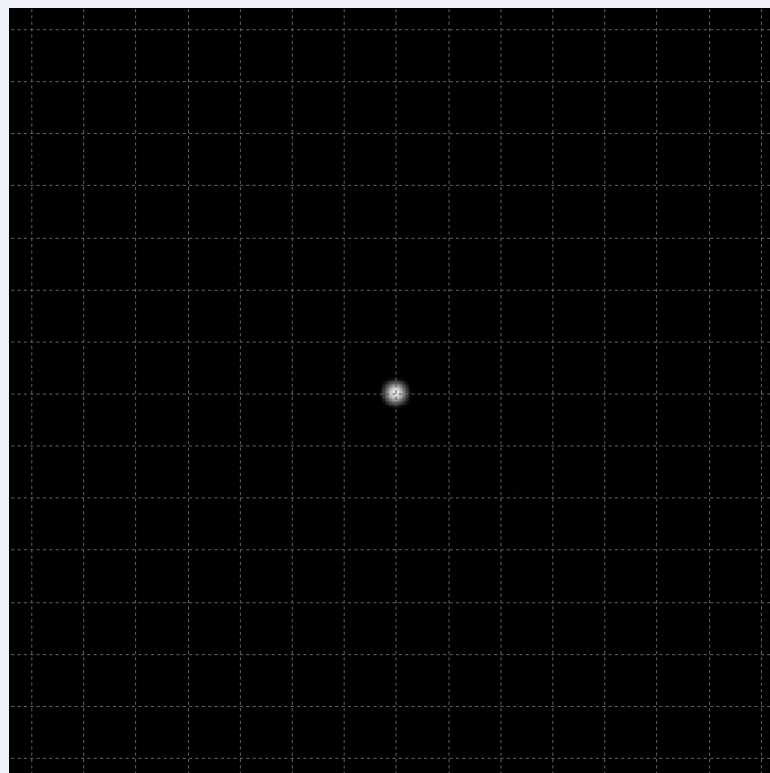

LED used for simulation	Cree XP-G
Luminous flux of LED [lm]	36
FWHM Co [°]	5
FWHM C90 [°]	5

* The ratio between luminous flux on the projection wall (3x3 m at 1 m) and luminous flux of LED

A234 7733

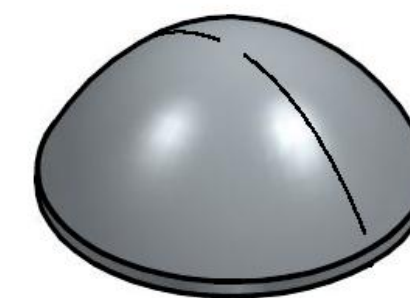
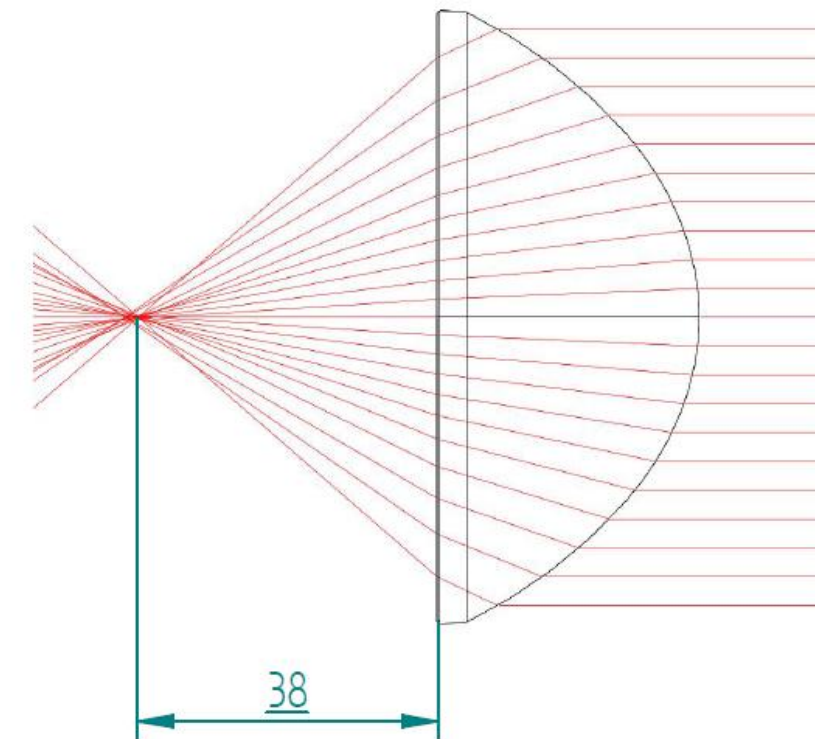
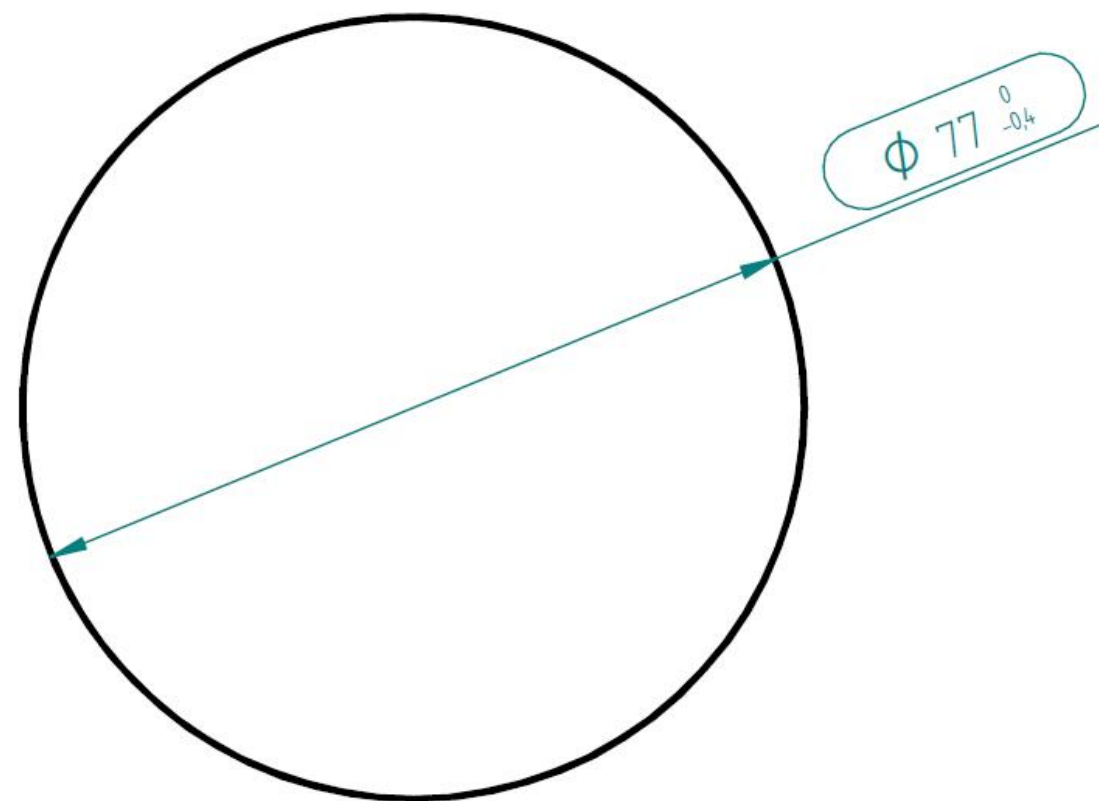
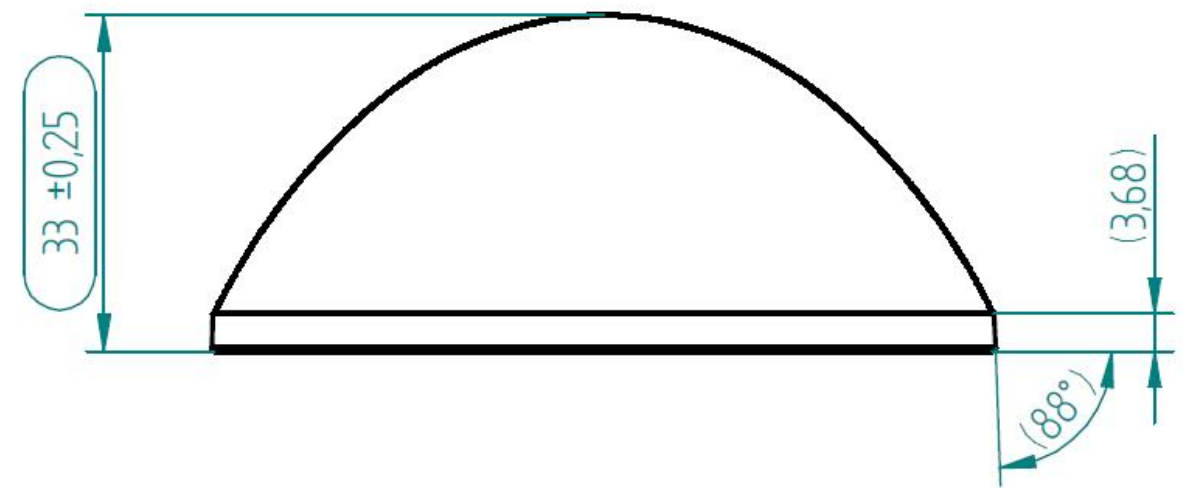

material : GLASS nd=1,520

REVISION HISTORY			
REV	DESCRIPTION	DATE	APPROVED

	NAME	DATE		
DRAWN	jkocarek	06/12/25		
CHECKED				
ENG APPR				
MGR APPR			TITLE	
			A234 7733	
UNLESS OTHERWISE SPECIFIED DIMENSIONS ARE IN MILLIMETERS			SIZE A4	DWG NO Aspheric Lens
			FILE NAME A2347733.dft	REV
			SCALE:	WEIGHT:
			SHEET 1 OF 1	

A234 7733 – simulation results

- Polar Candela Distribution Plot

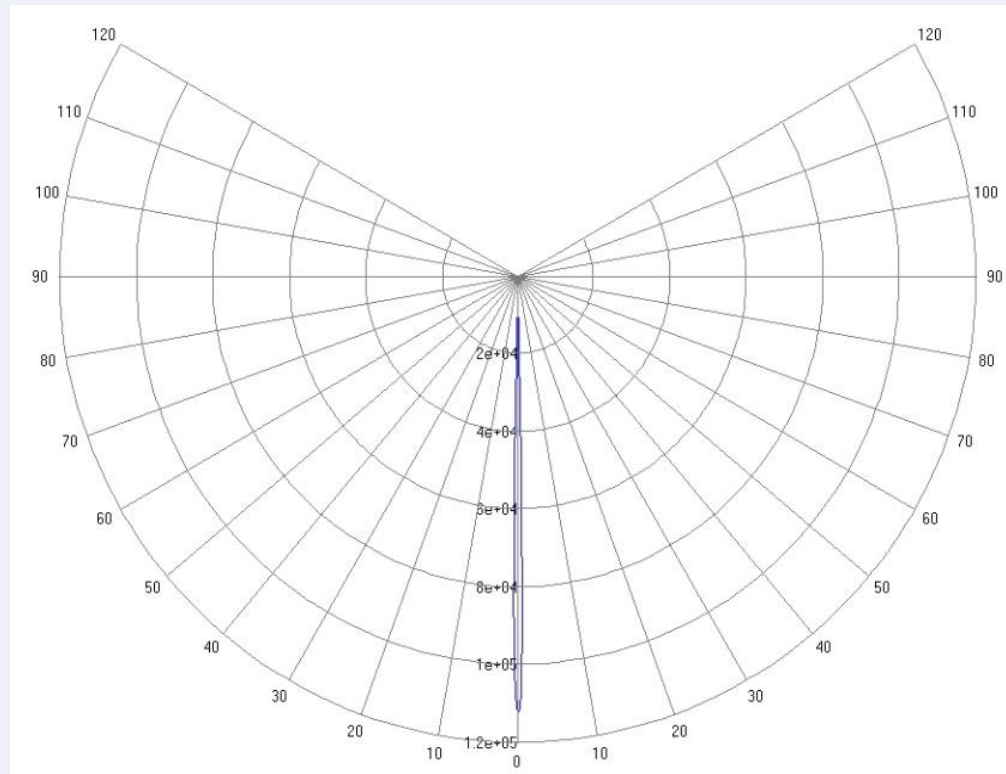

- Rectangular Candela Distribution Plot

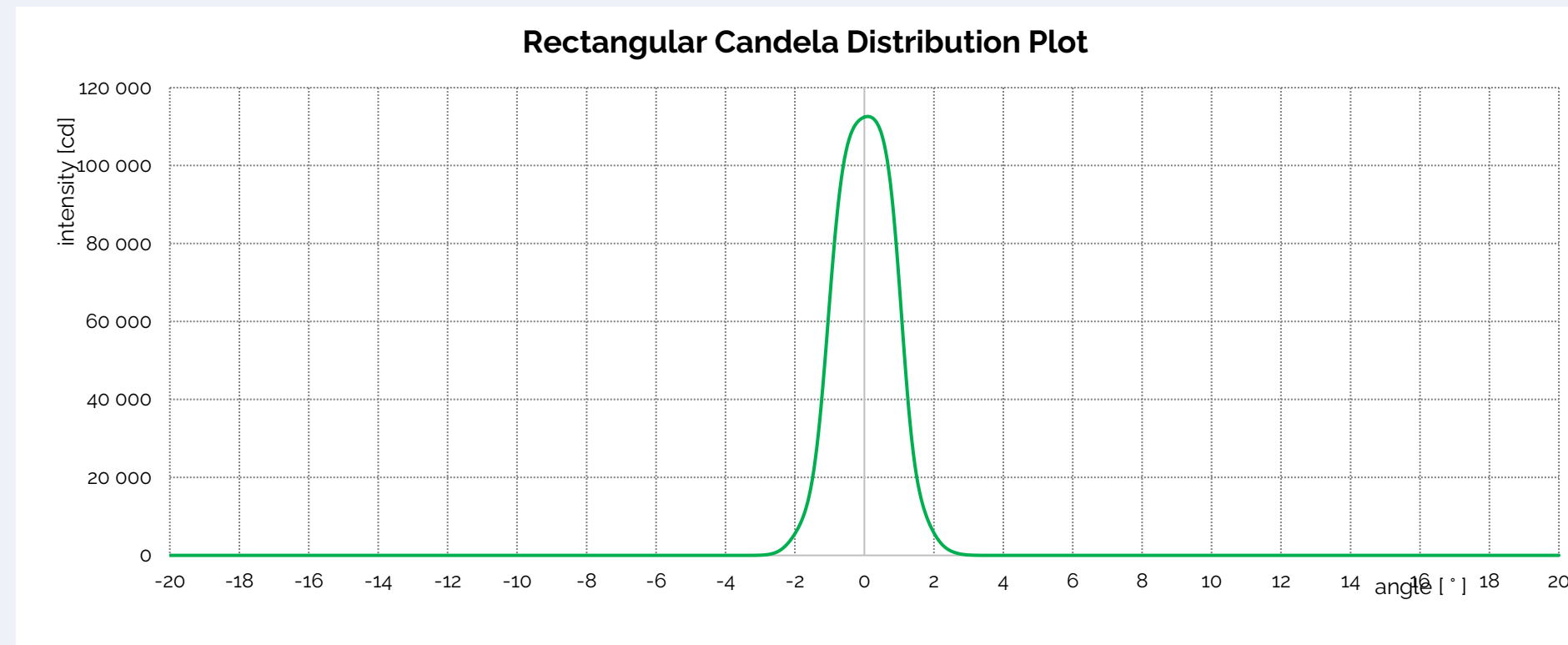

- Projection wall 3x3 m at 1m

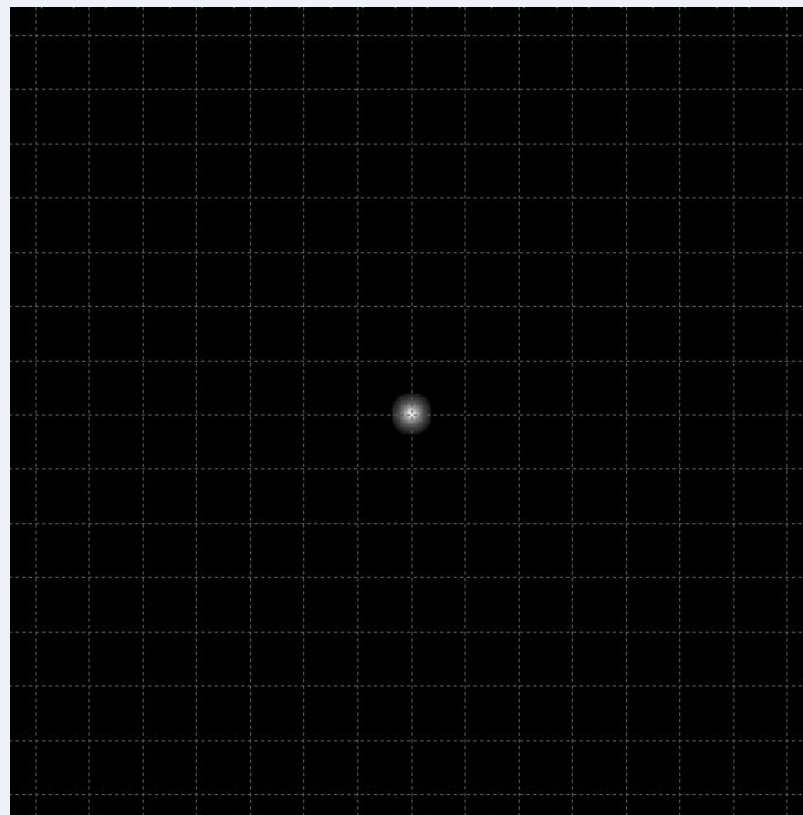

LED used for simulation	Cree XP-G4
Luminous flux of LED [lm]	350
FWHM Co [°]	2
FWHM C180 [°]	2

A373 4508

REVISION HISTORY			
REV.	DESCRIPTION	DATE	APPROVED

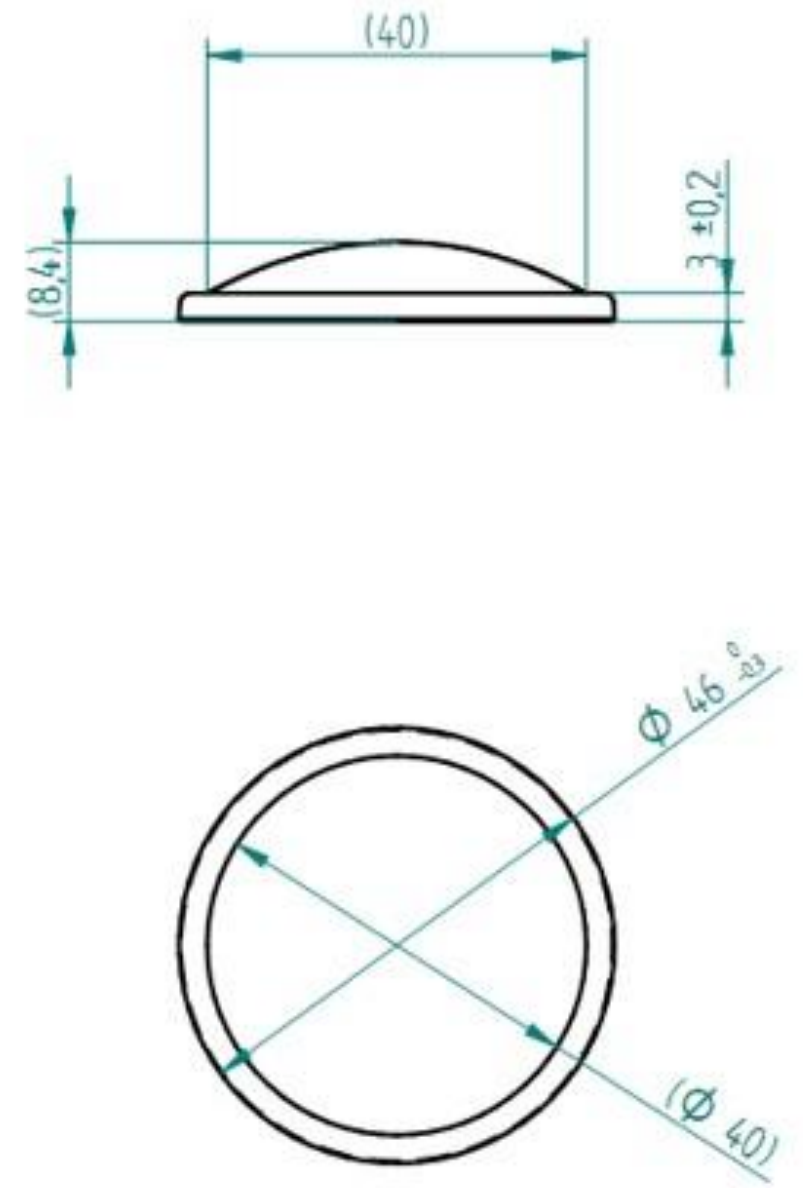

SCALE 1:2



Glass: LIBA or alternative (nd = 1,521)

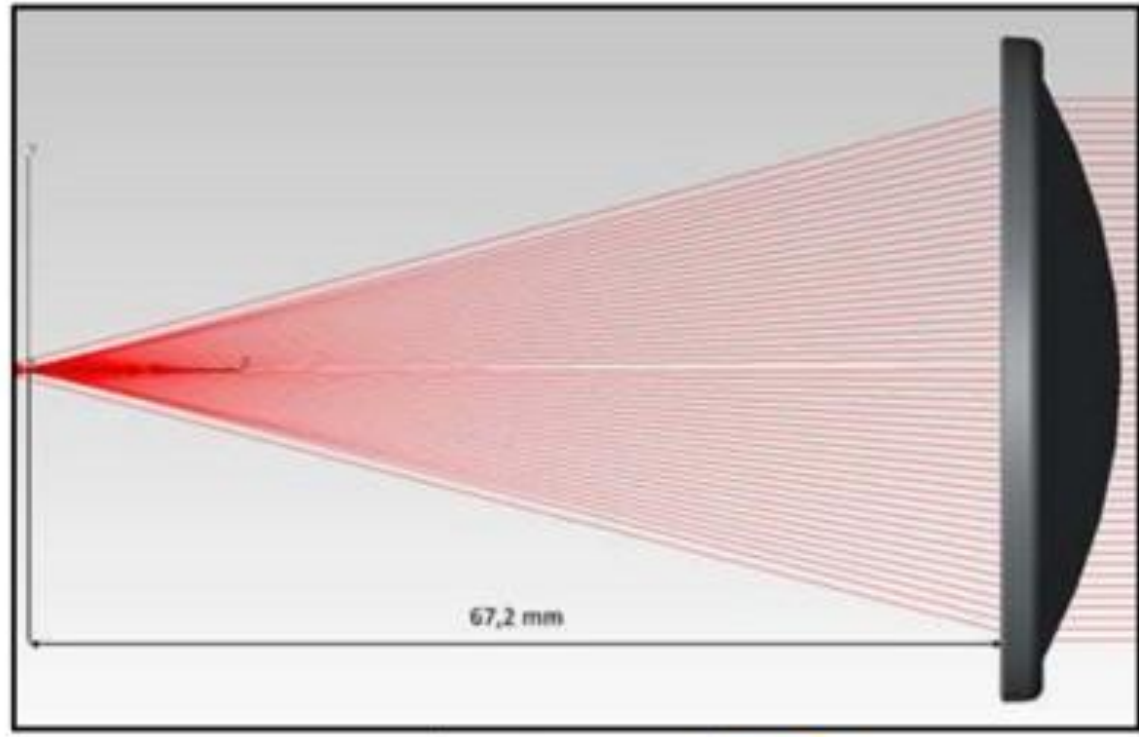

DRAWN	NAME	DATE	 A373 4508
CHECKED			
ENG APPR			
MGR APPR			
UNLESS OTHERWISE SPECIFIED DIMENSIONS ARE IN MILLIMETERS			FILE NAME: A373L.dwg SCALE: WEIGHT: 21 g SHEET 1 OF 1

A373 4508 – simulation results

- Polar Candela Distribution Plot

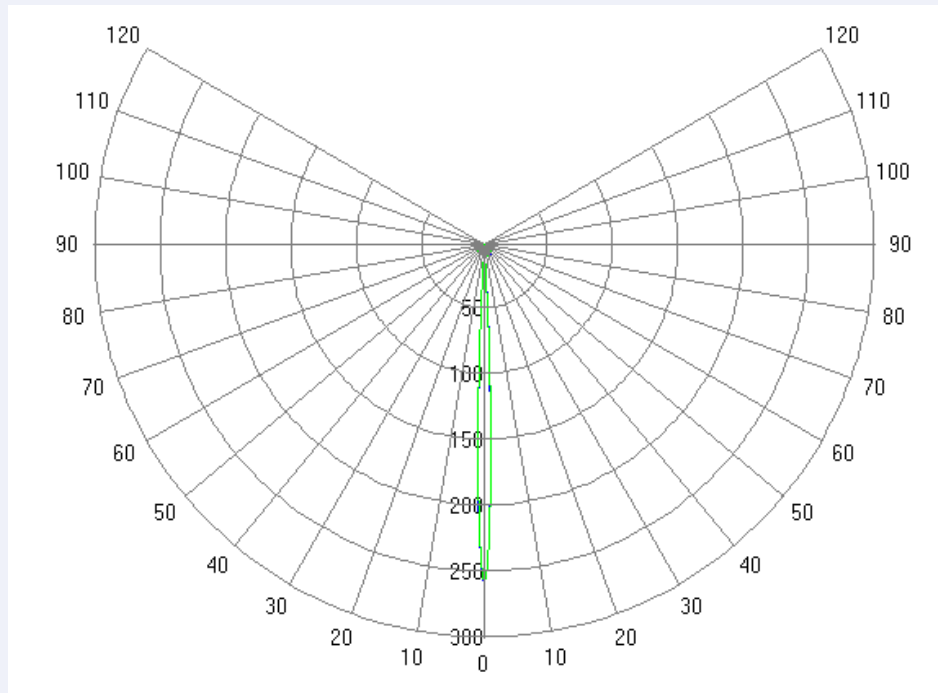

- Rectangular Candela Distribution Plot

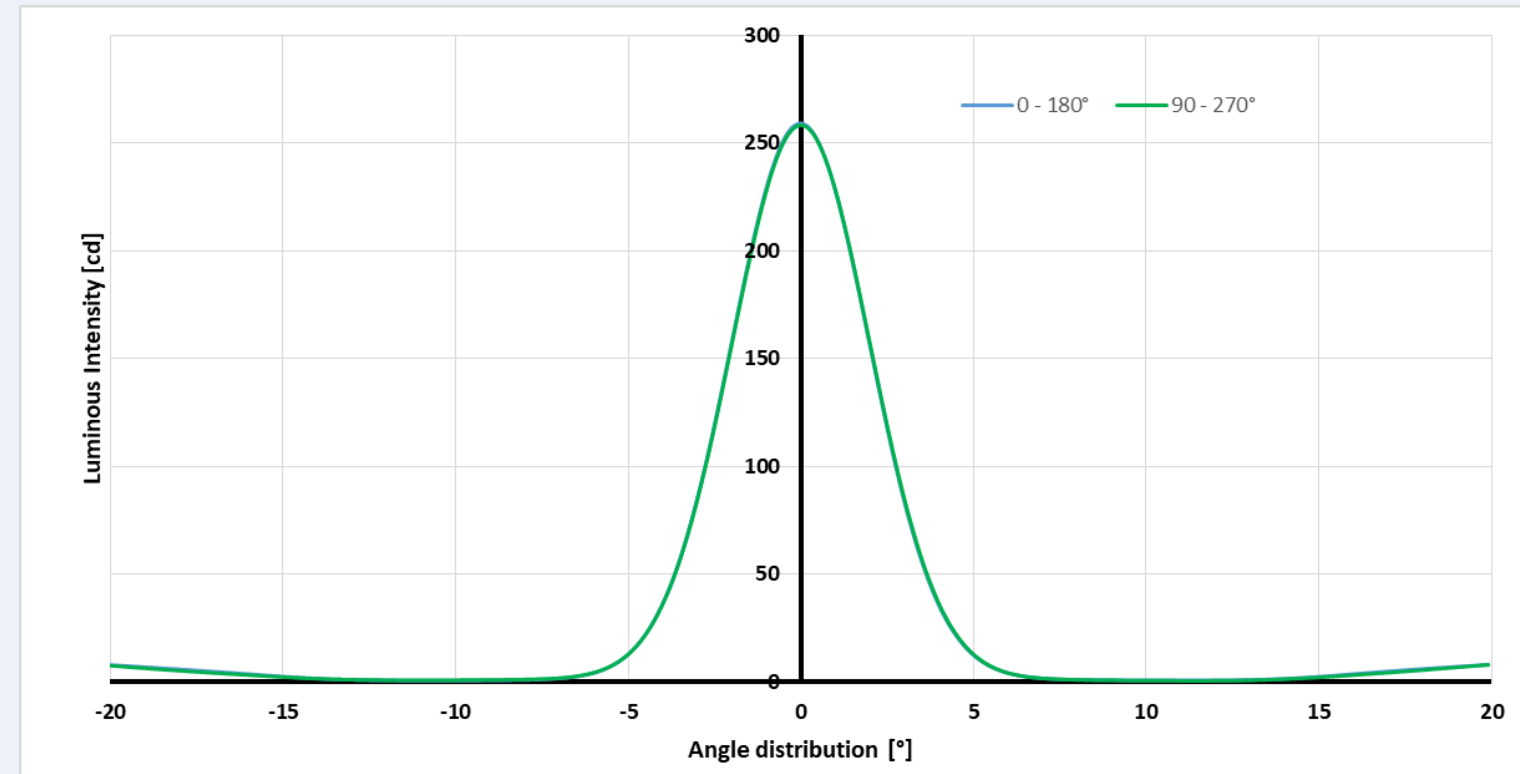

- Projection wall 3x3 m at 1m

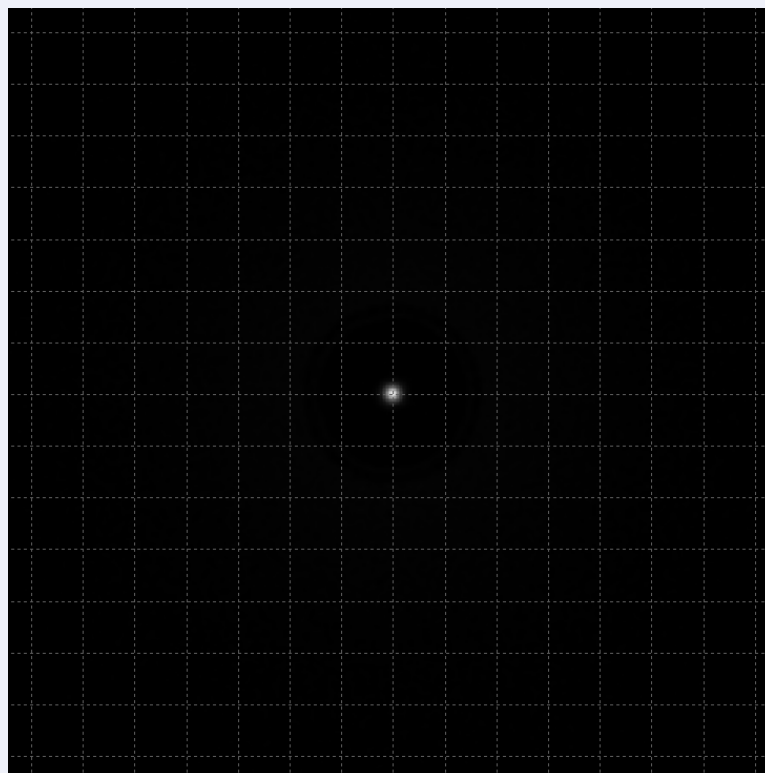

LED used for simulation	Cree XP-G
Luminous flux of LED [lm]	36
FWHM Co [°]	5
FWHM C90 [°]	5

* The ratio between luminous flux on the projection wall (3x3 m at 1 m) and luminous flux of LED

A413 1206

REVISION HISTORY			
REV	DESCRIPTION	DATE	APPROVED

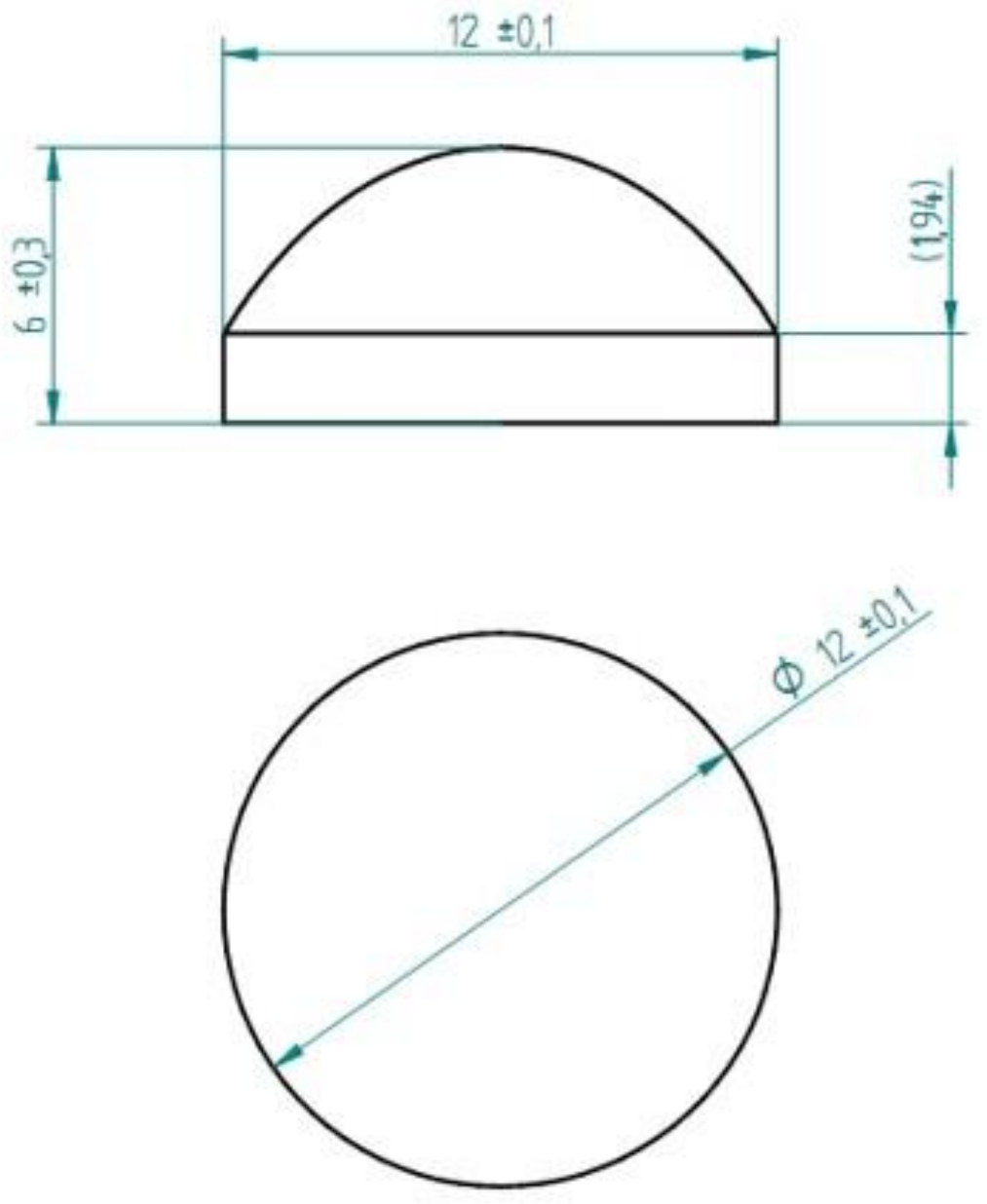

SCALE 3:1

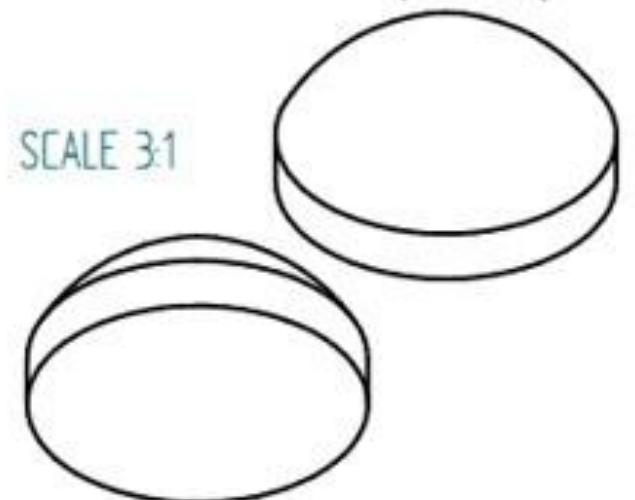
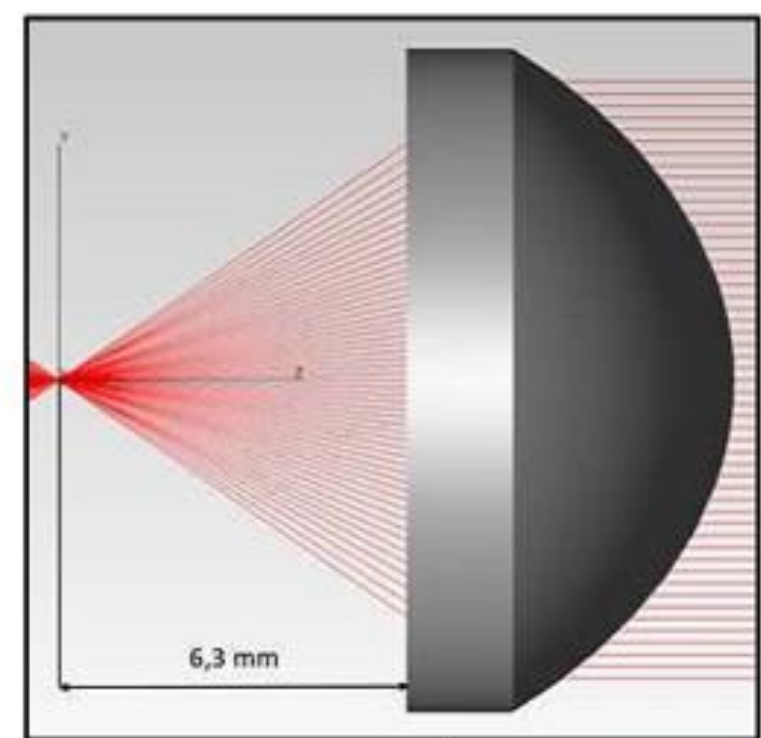



Glass: LIBA or alternative (nd = 1,521)

DRAWN	NAME	DATE	 ECOGLOSS
CHECKED	frutsky	05/15/22	
ENG APPR			
MGR APPR			
UNLESS OTHERWISE SPECIFIED DIMENSIONS ARE IN MILLIMETERS			A413 1206
SCALE	WEIGHT	1 g	SHEET 1 OF 1

A413 1206 – simulation results

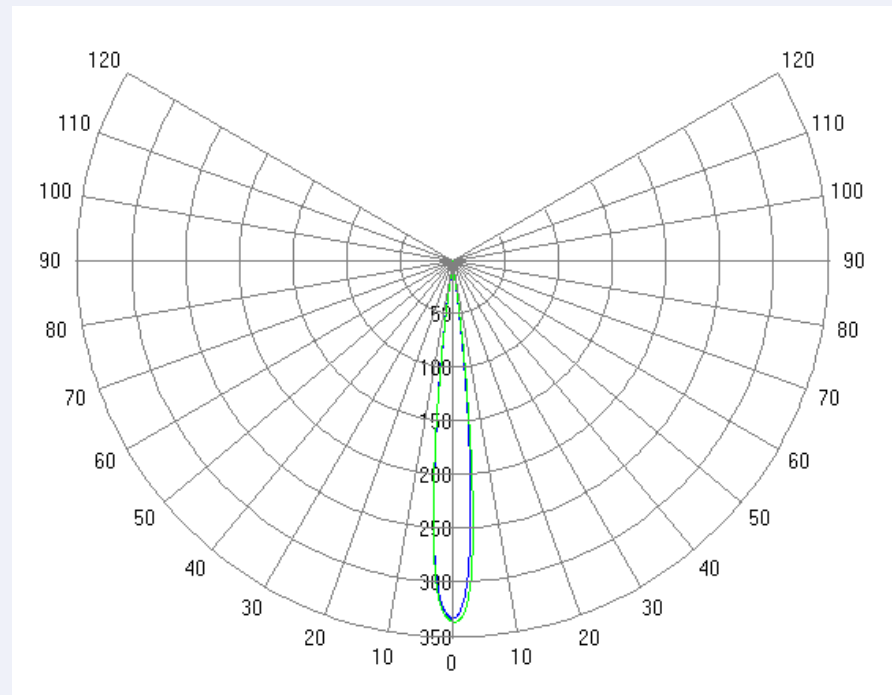
- Polar Candela Distribution Plot



- Rectangular Candela Distribution Plot

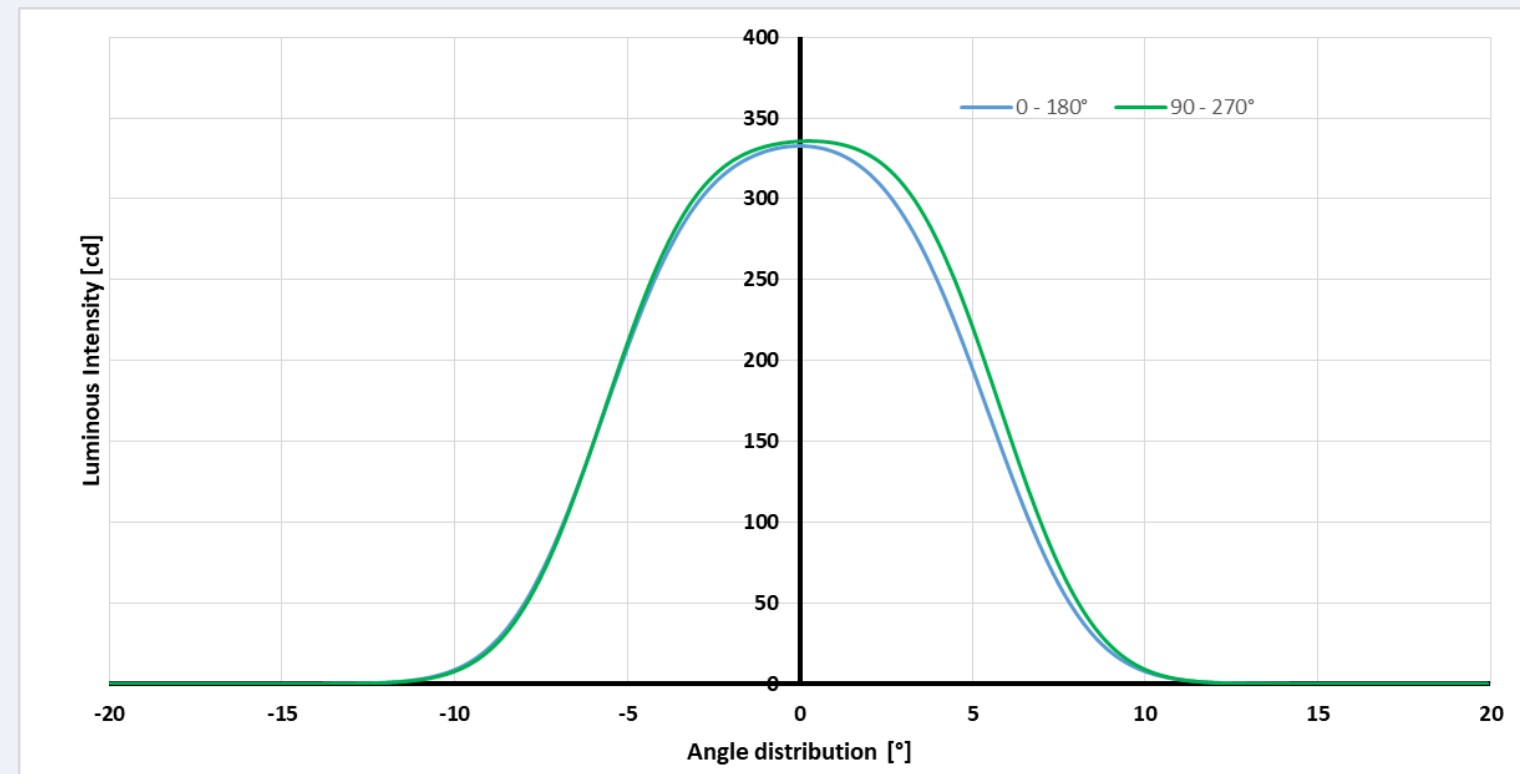

- Projection wall 3x3 m at 1m

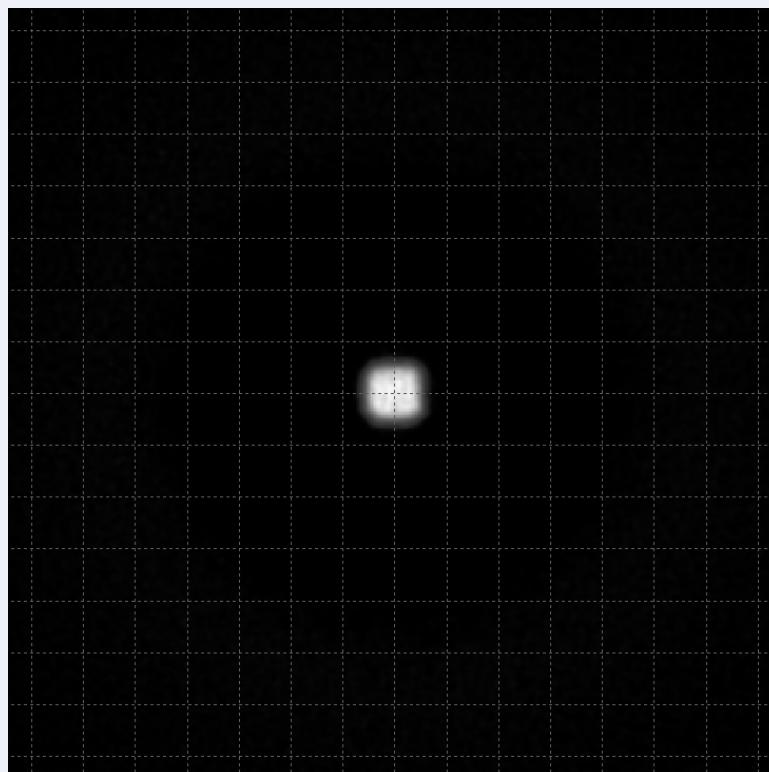

LED used for simulation	Cree XP-G
Luminous flux of LED [lm]	36
FWHM Co [°]	6
FWHM C90 [°]	6

* The ratio between luminous flux on the projection wall (3x3 m at 1 m) and luminous flux of LED

A501 2207

REVISION HISTORY			
REV.	DESCRIPTION	DATE	APPROVED

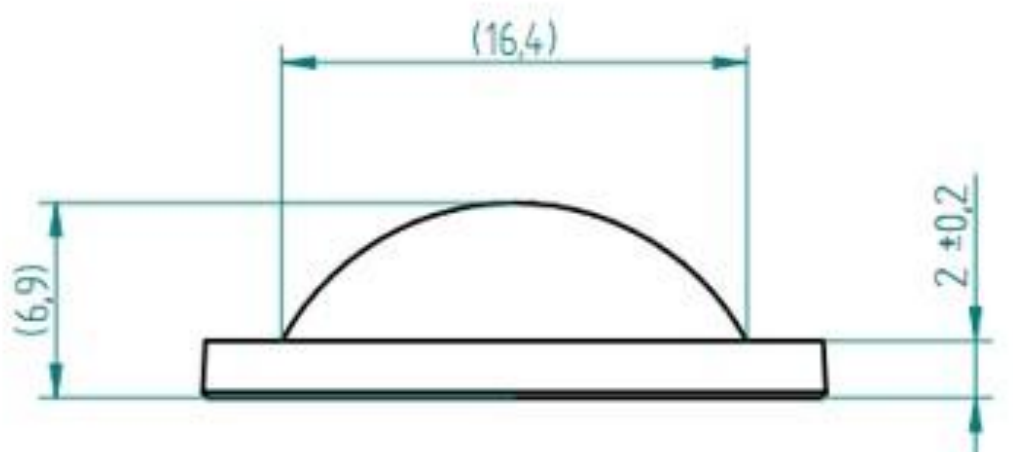
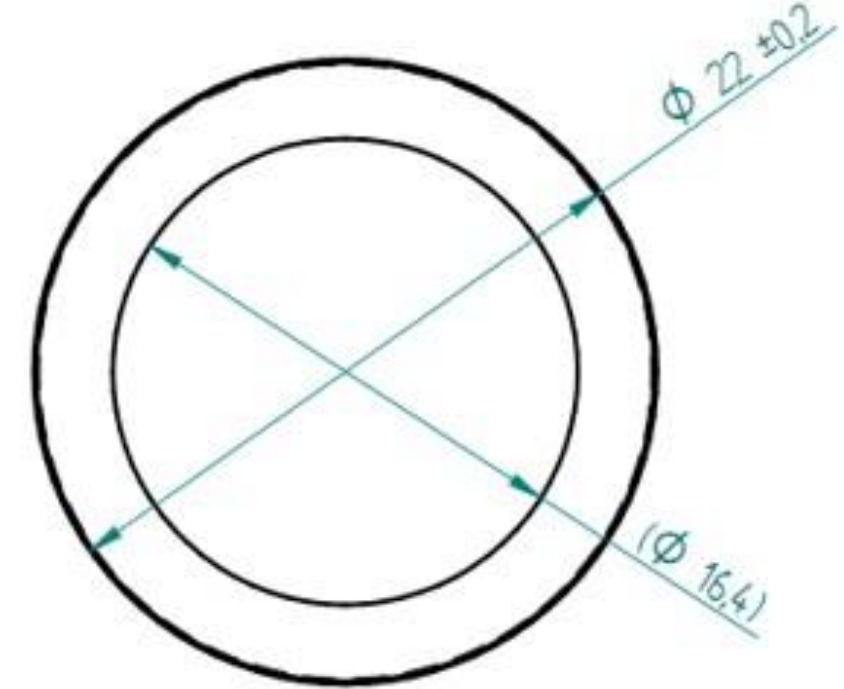
SCALE 2:1



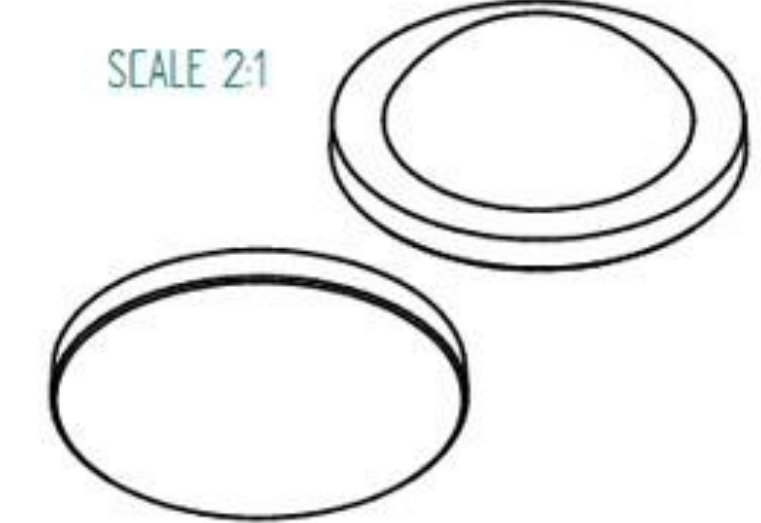
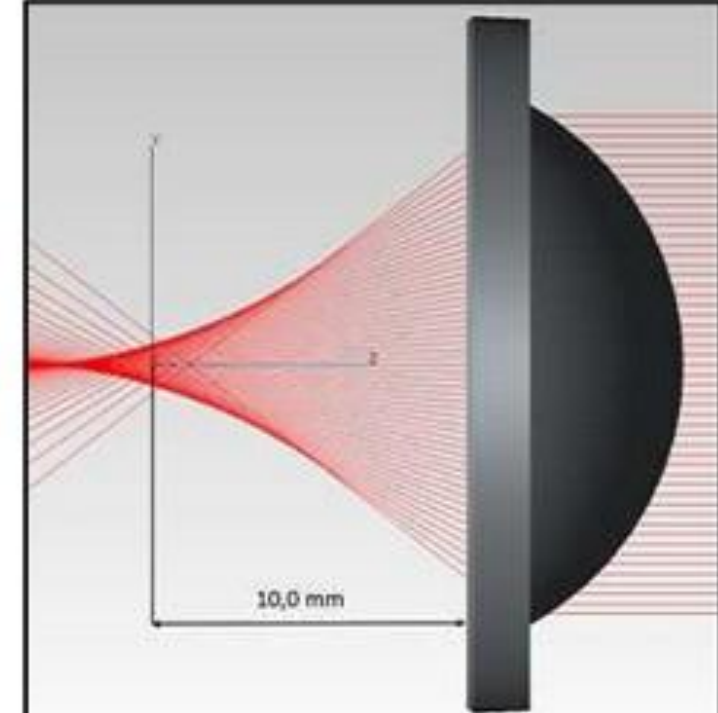

Glass: LIBA or alternative (nd = 1,521)

DRAWN	krutky	DATE	05/15/00	 <p style="font-size: 1.2em; margin: 0;">A501 2207</p>															
CHECKED																			
ENG APPR																			
MGR APPR																			
UNLESS OTHERWISE SPECIFIED DIMENSIONS ARE IN MILLIMETERS				<table style="width: 100%; border: none;"> <tr> <td style="border: none;">SIZE</td> <td style="border: none;">DWG NO</td> <td style="border: none;">REV</td> </tr> <tr> <td style="border: none;">A4</td> <td style="border: none;"> </td> <td style="border: none;"> </td> </tr> <tr> <td colspan="3" style="border: none; font-size: 0.7em;">FILE NAME: A501_ansil.dwg</td> </tr> <tr> <td style="border: none;">SCALE</td> <td style="border: none;">WEIGHT</td> <td style="border: none;">SHEET 1 OF 1</td> </tr> <tr> <td style="border: none;"> </td> <td style="border: none;">3 g</td> <td style="border: none;"> </td> </tr> </table>	SIZE	DWG NO	REV	A4			FILE NAME: A501_ansil.dwg			SCALE	WEIGHT	SHEET 1 OF 1		3 g	
SIZE	DWG NO	REV																	
A4																			
FILE NAME: A501_ansil.dwg																			
SCALE	WEIGHT	SHEET 1 OF 1																	
	3 g																		

A501 2207 – simulation results

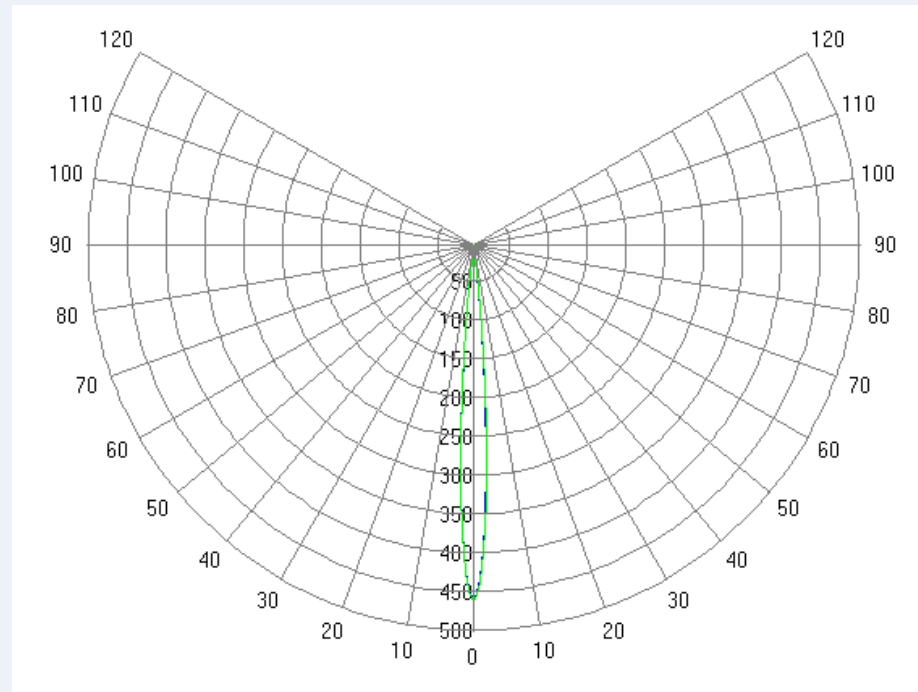
- Polar Candela Distribution Plot



- Rectangular Candela Distribution Plot

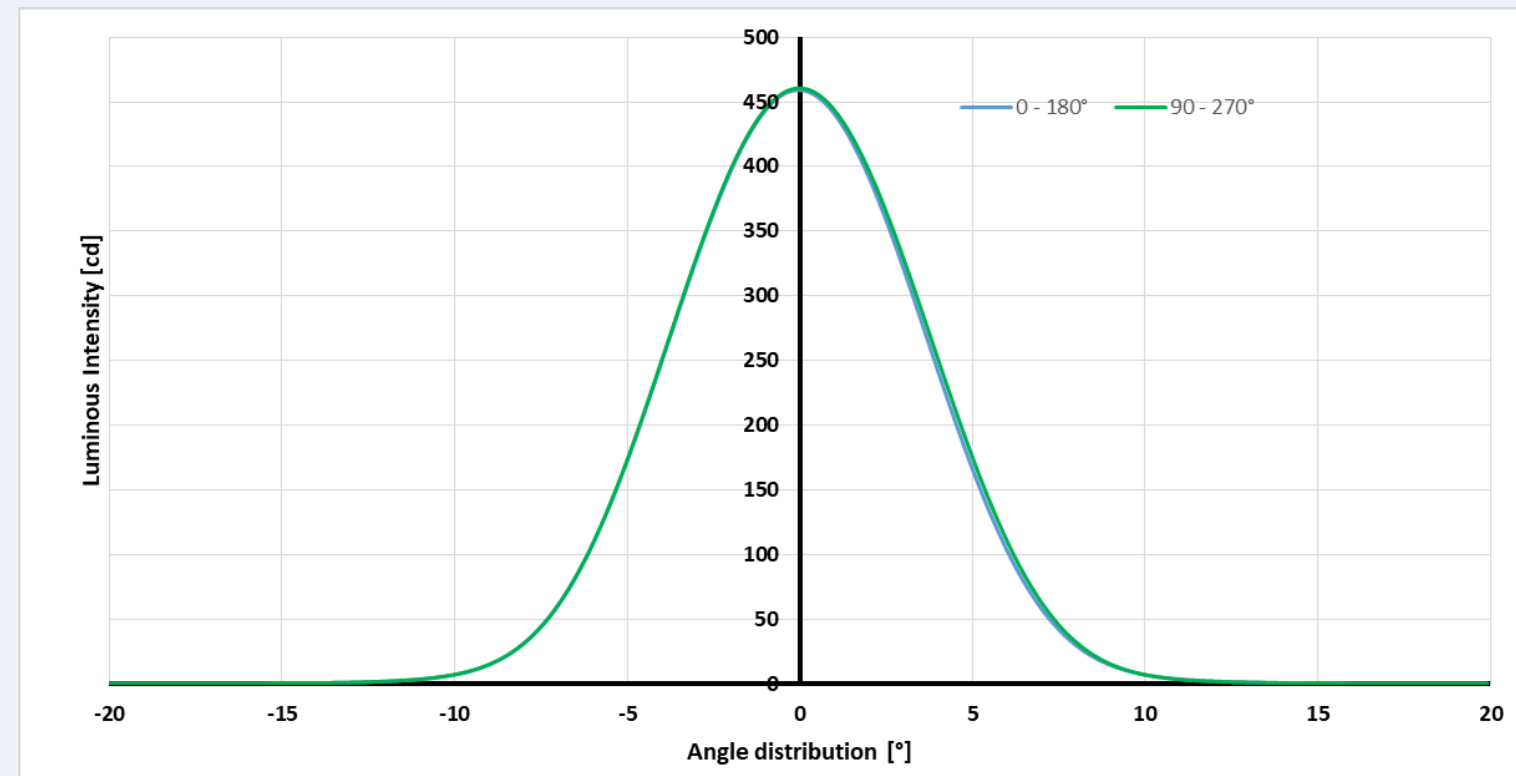

- Projection wall 5x5 m at 1m

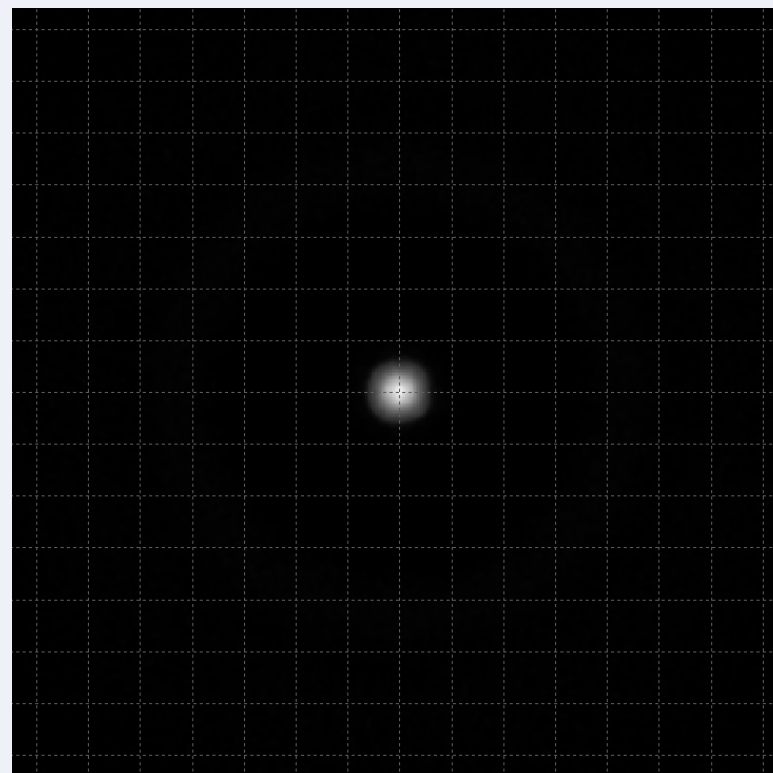

LED used for simulation	Cree XP-G
Luminous flux of LED [lm]	36
FWHM Co [°]	8,5
FWHM C90 [°]	8,5

* The ratio between luminous flux on the projection wall (5x5 m at 1 m) and luminous flux of LED

A581 2808

REVISION HISTORY			
REV	DESCRIPTION	DATE	APPROVED

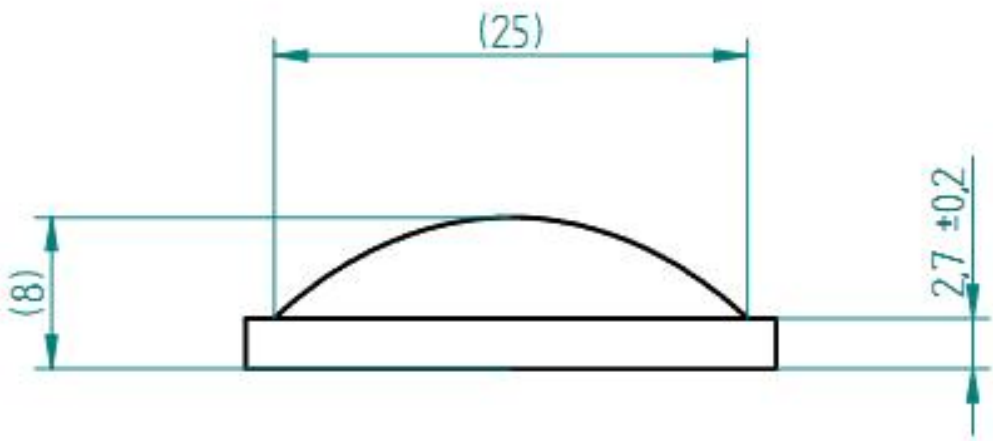
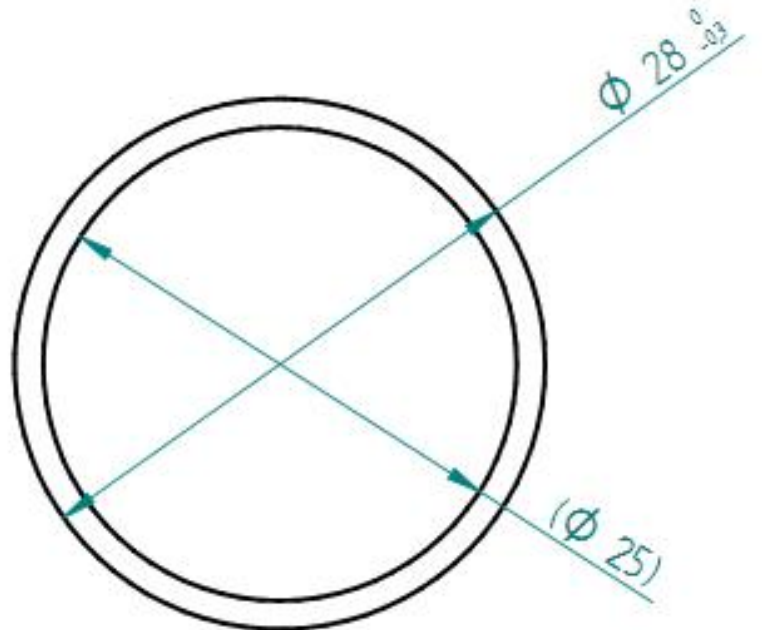
SCALE 1:1



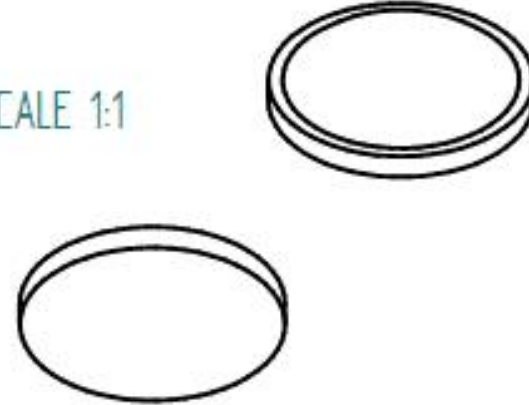

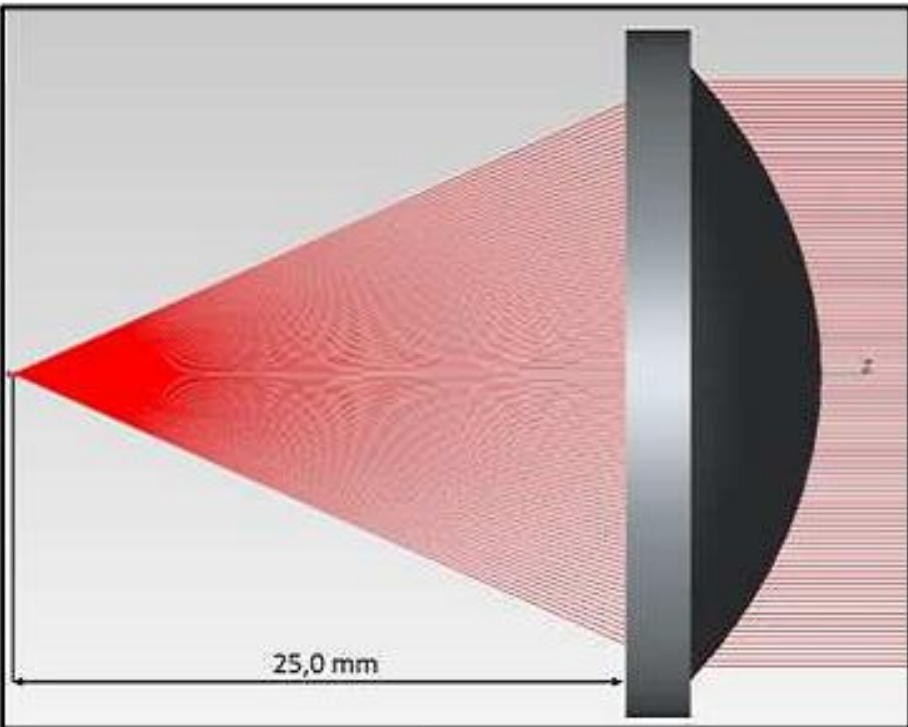
DRAWN	krutsky	DATE	05/29/20	
CHECKED				
ENG APPR				
MGR APPR				
UNLESS OTHERWISE SPECIFIED, DIMENSIONS ARE IN MILLIMETERS				<p style="text-align: center; font-weight: bold; font-size: 1.2em;">A581 2808</p> <p>FILE NAME: A581_small.dxf</p>
SCALE		WEIGHT	8 g	SHEET 1 OF 1

Glass: LIBA or alternative (nd = 1,521)

A581 2808 – simulation results

- Polar Candela Distribution Plot

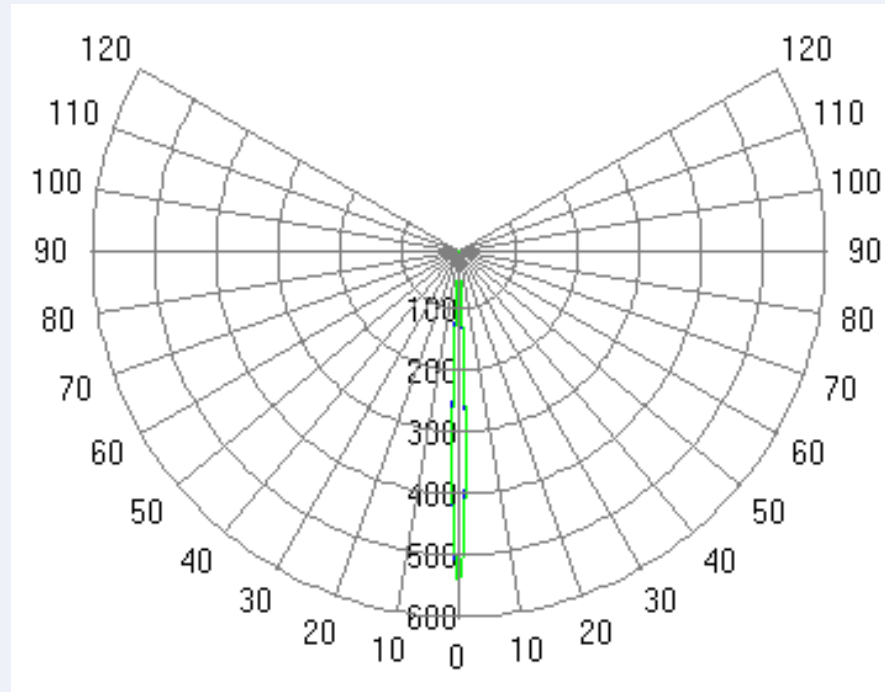

- Rectangular Candela Distribution Plot

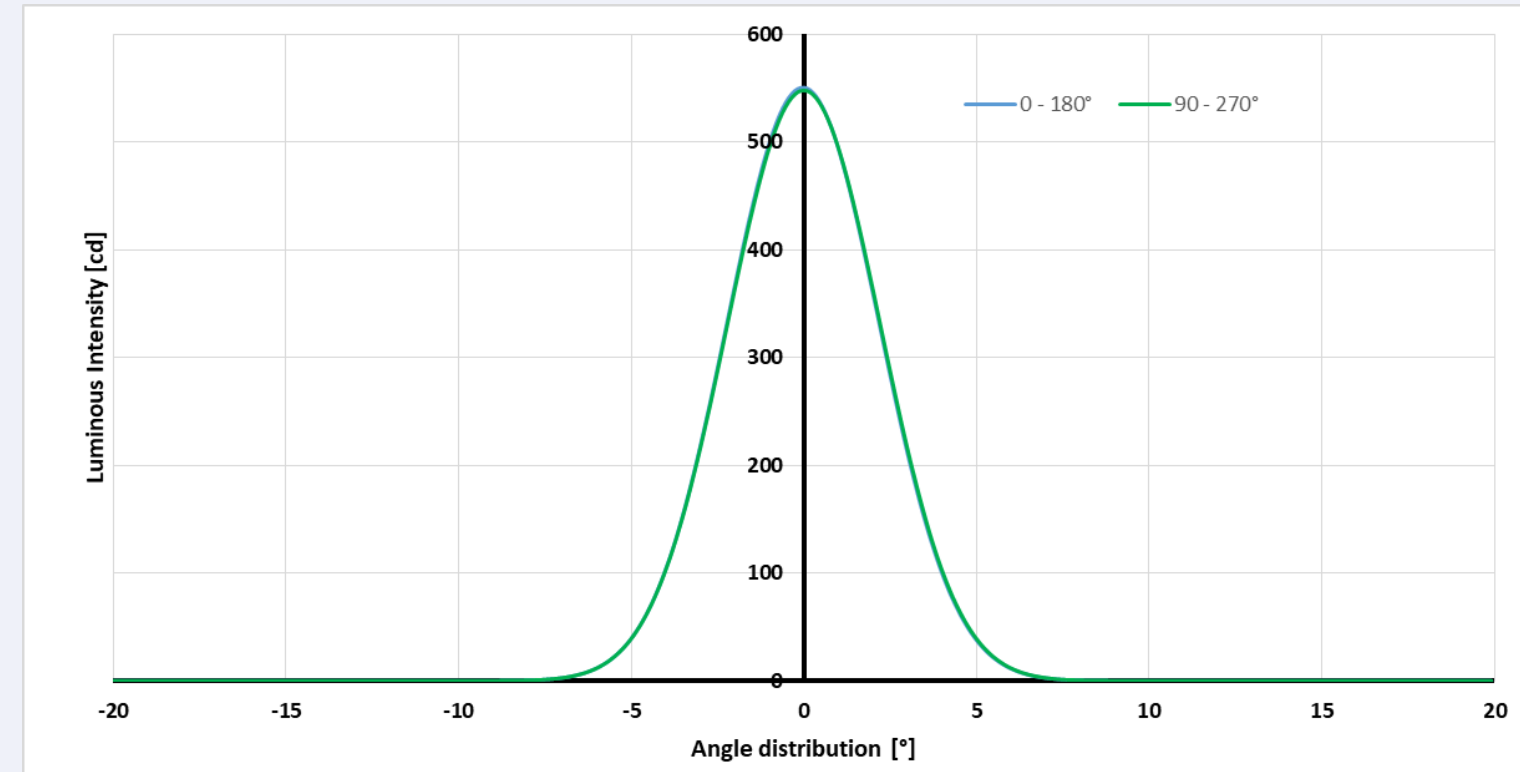

- Projection wall 5x5 m at 1m

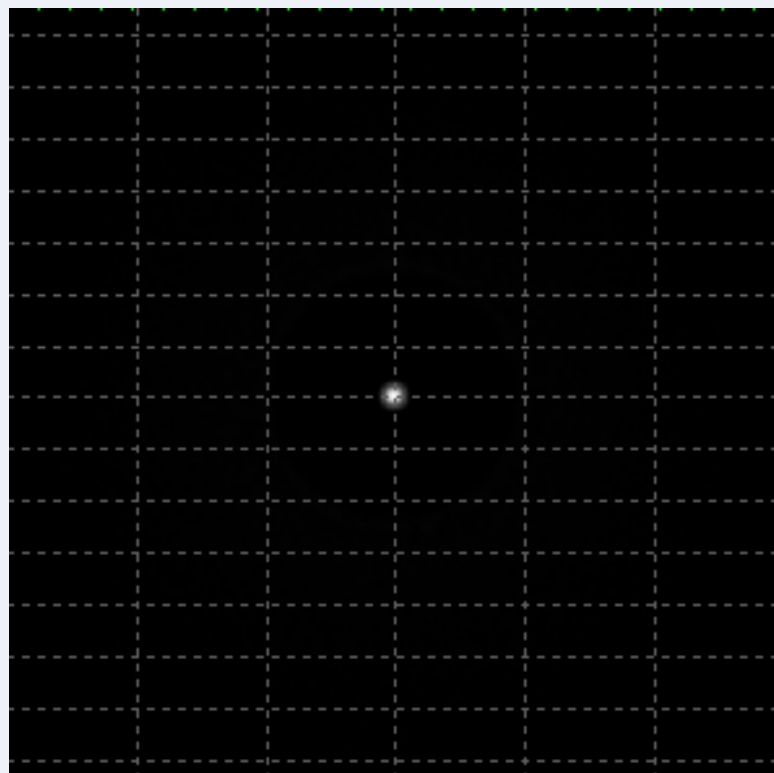

LED used for simulation	Cree XP-G
Luminous flux of LED [lm]	36
FWHM Co [°]	5
FWHM C90 [°]	5

* The ratio between luminous flux on the projection wall (5x5 m at 1 m) and luminous flux of LED

A582 7522

REVISION HISTORY			
REV	DESCRIPTION	DATE	APPROVED

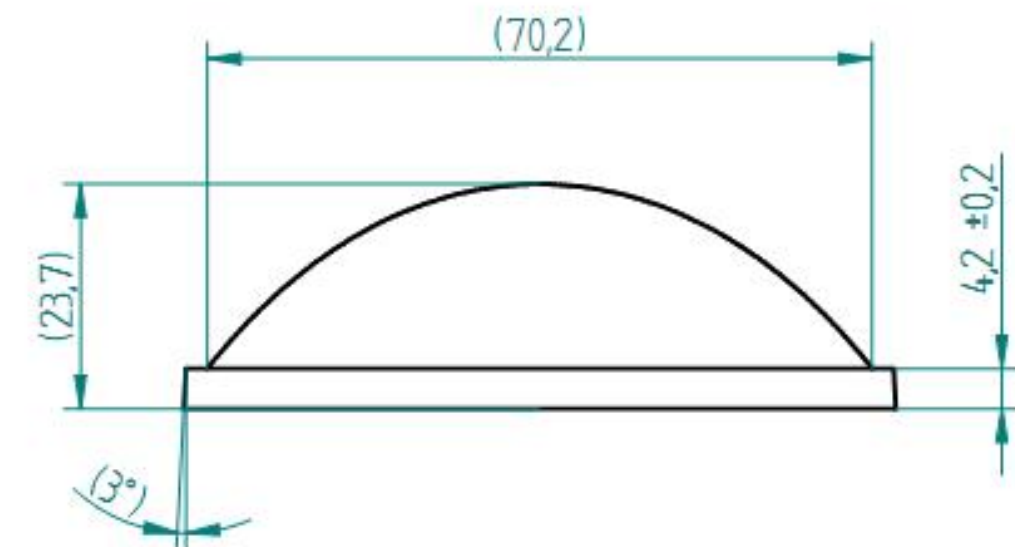
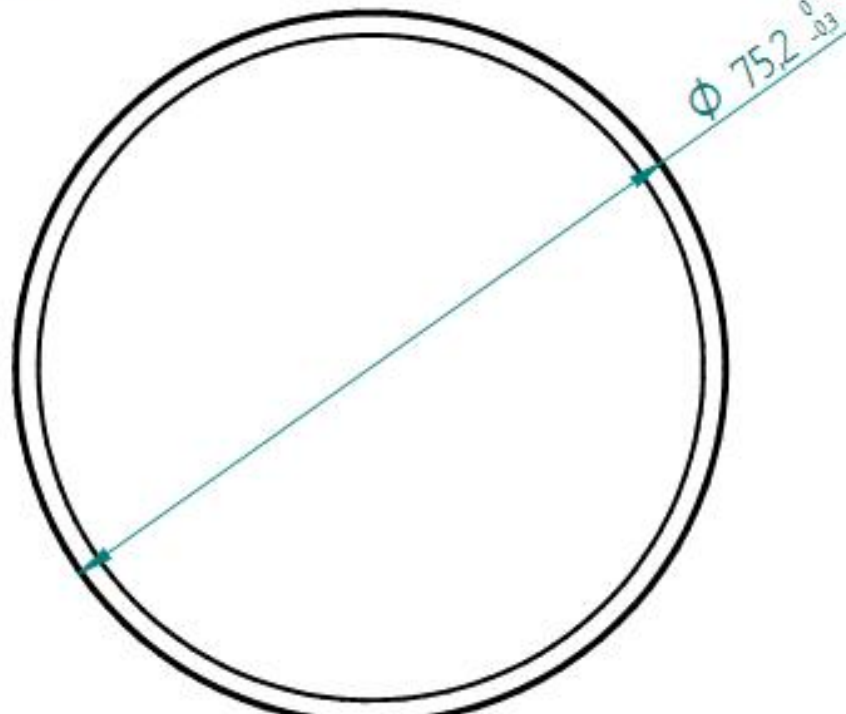

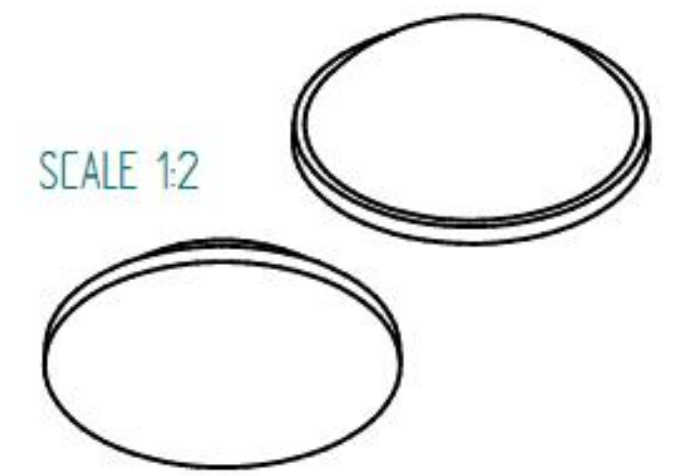

SCALE 1:2

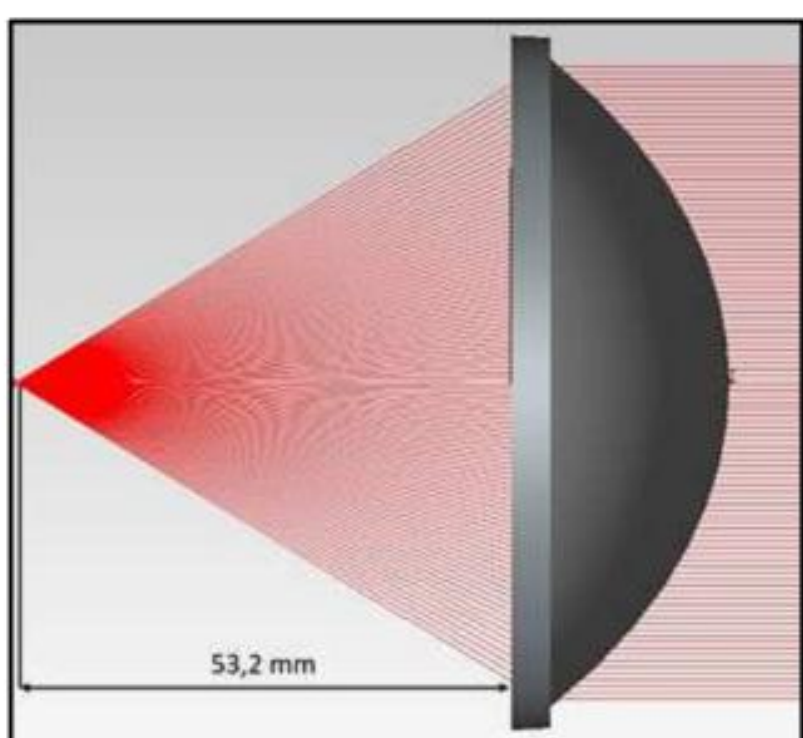

Glass: LIBA or alternative (nd = 1,521)



DRAWN	krutsky	DATE	05/29/20	 <p>A582 7522</p>															
CHECKED																			
ENG APPR																			
MGR APPR																			
UNLESS OTHERWISE SPECIFIED DIMENSIONS ARE IN MILLIMETERS				<table border="1" style="width: 100%; border-collapse: collapse;"> <tr> <td style="font-size: x-small;">SIZE</td> <td style="font-size: x-small;">DWG NO</td> <td style="font-size: x-small;">REV</td> </tr> <tr> <td style="font-size: x-small;">A4</td> <td> </td> <td> </td> </tr> <tr> <td colspan="3" style="font-size: x-small;">FILE NAME: A582_smal.dwg</td> </tr> <tr> <td style="font-size: x-small;">SCALE</td> <td style="font-size: x-small;">WEIGHT</td> <td style="font-size: x-small;">SHEET 1 OF 1</td> </tr> <tr> <td> </td> <td>150 g</td> <td> </td> </tr> </table>	SIZE	DWG NO	REV	A4			FILE NAME: A582_smal.dwg			SCALE	WEIGHT	SHEET 1 OF 1		150 g	
SIZE	DWG NO	REV																	
A4																			
FILE NAME: A582_smal.dwg																			
SCALE	WEIGHT	SHEET 1 OF 1																	
	150 g																		

A582 7522 – simulation results

- Polar Candela Distribution Plot

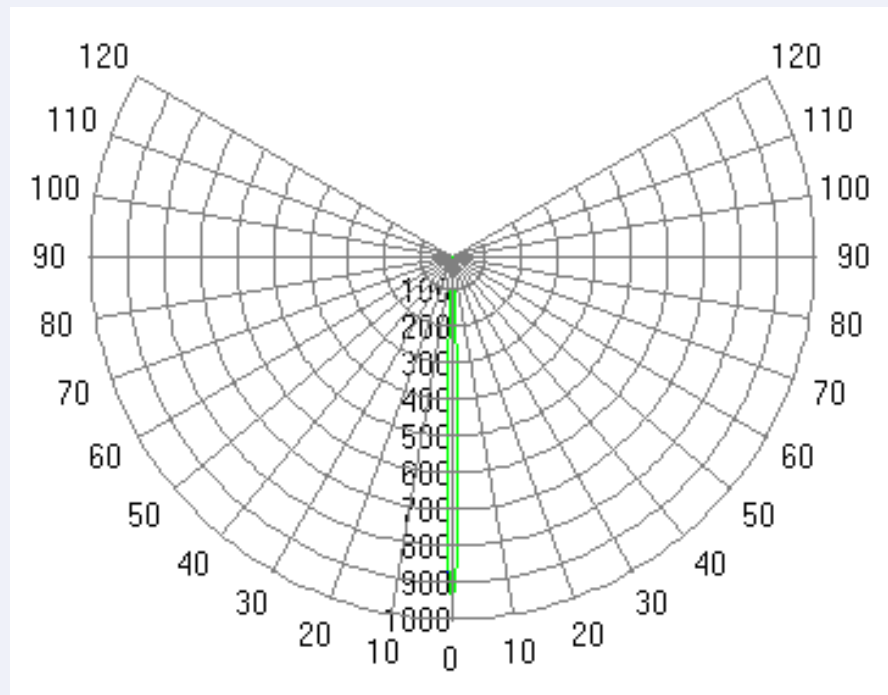

- Rectangular Candela Distribution Plot

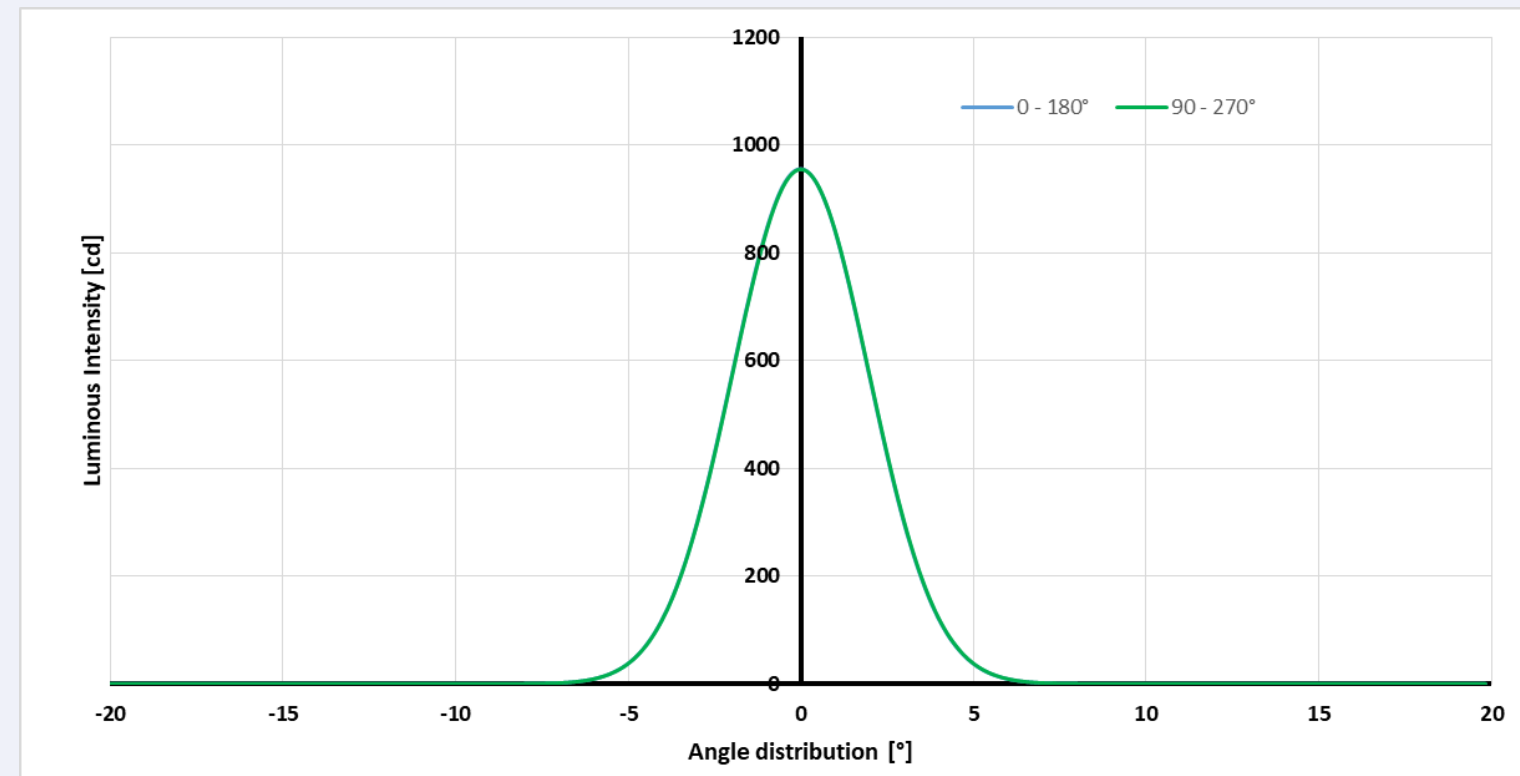

- Projection wall 5x5 m at 1m

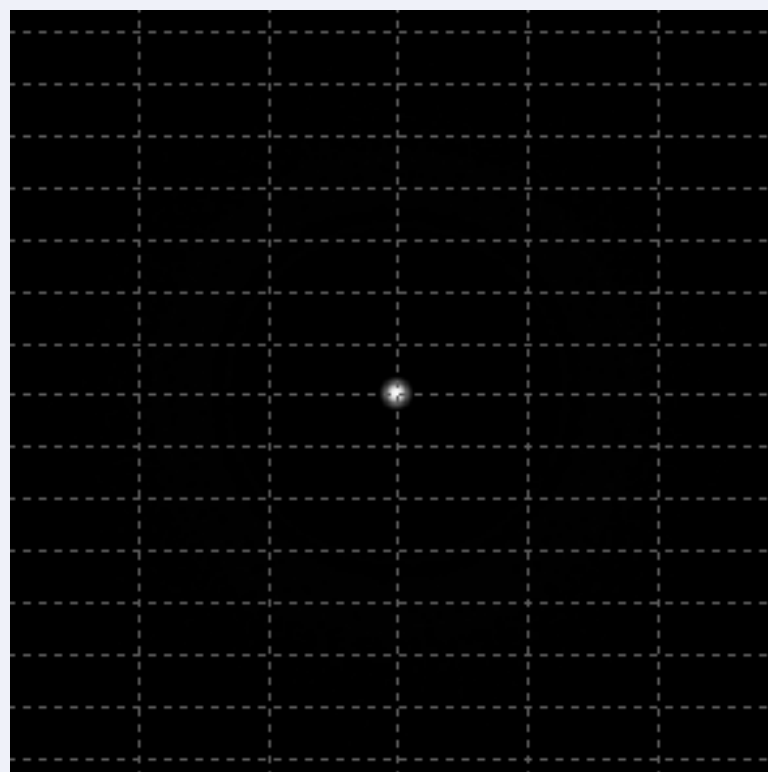

LED used for simulation	Cree XP-G
Luminous flux of LED [lm]	36
FWHM Co [°]	5
FWHM C90 [°]	5

* The ratio between luminous flux on the projection wall (5x5 m at 1 m) and luminous flux of LED

A636 5422

REVISION HISTORY			
REV	DESCRIPTION	DATE	APPROVED

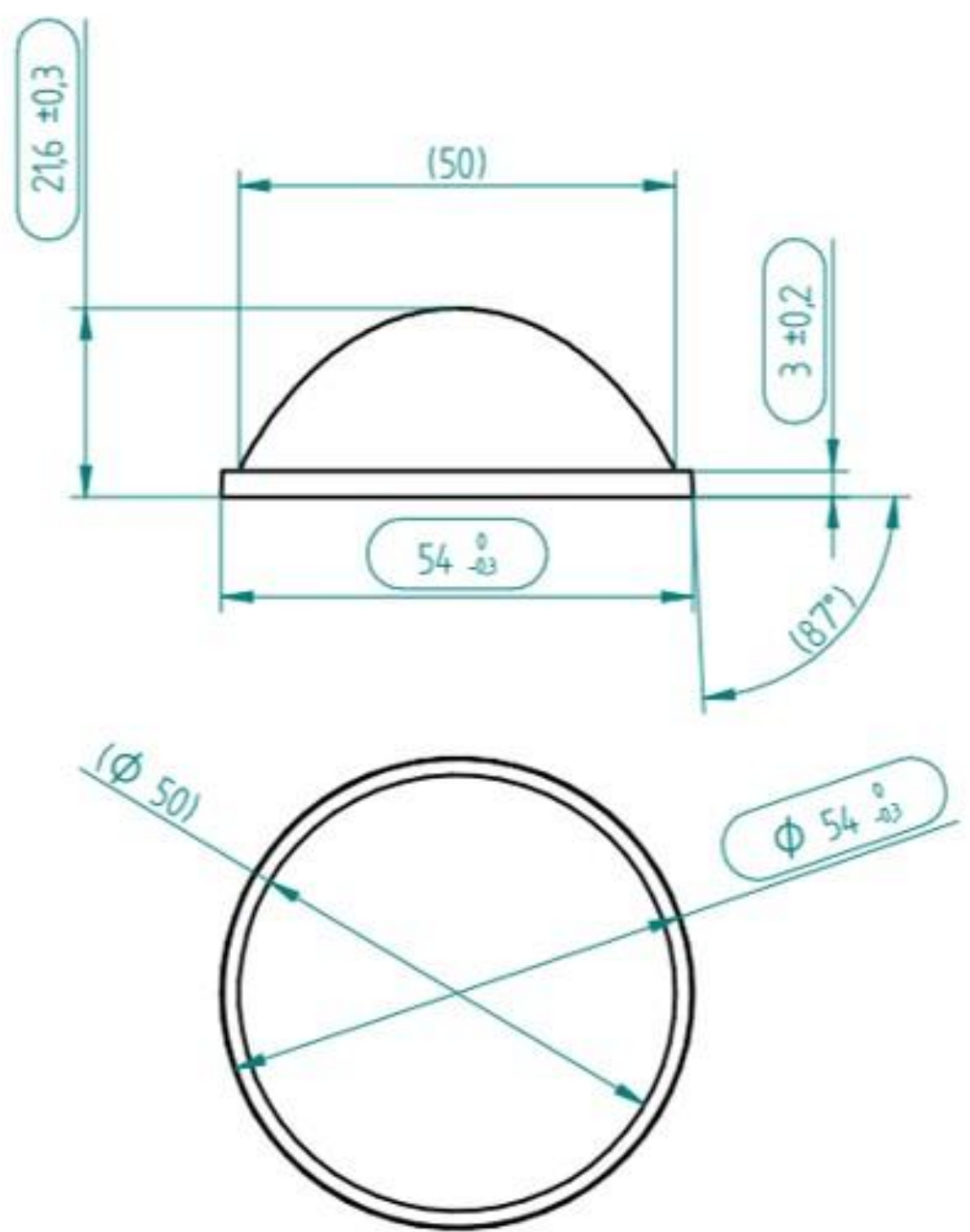

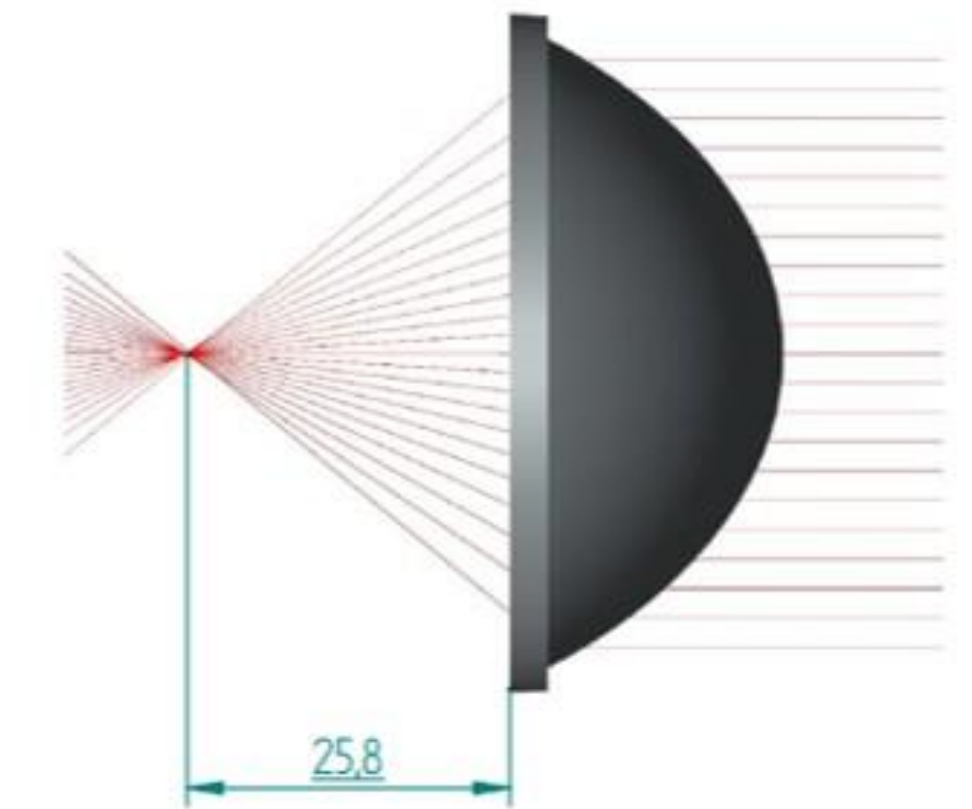

material : GLASS nd = 1.520

	NAME	DATE			
DRAWN	jkocarek	10/20/23			
CHECKED					
ENG APPR					
MGR APPR			TITLE aspheric lens		
UNLESS OTHERWISE SPECIFIED DIMENSIONS ARE IN MILLIMETERS ANGLES ±XX° 2 PL ±XXX 3 PL ±XXXX			SIZE A4	DWG NO A636 5422	REV
			FILE NAME: A636 5422.dft		
			SCALE:	WEIGHT:	SHEET 1 OF 1

A636 5422 – simulation results



- Polar Candela Distribution Plot

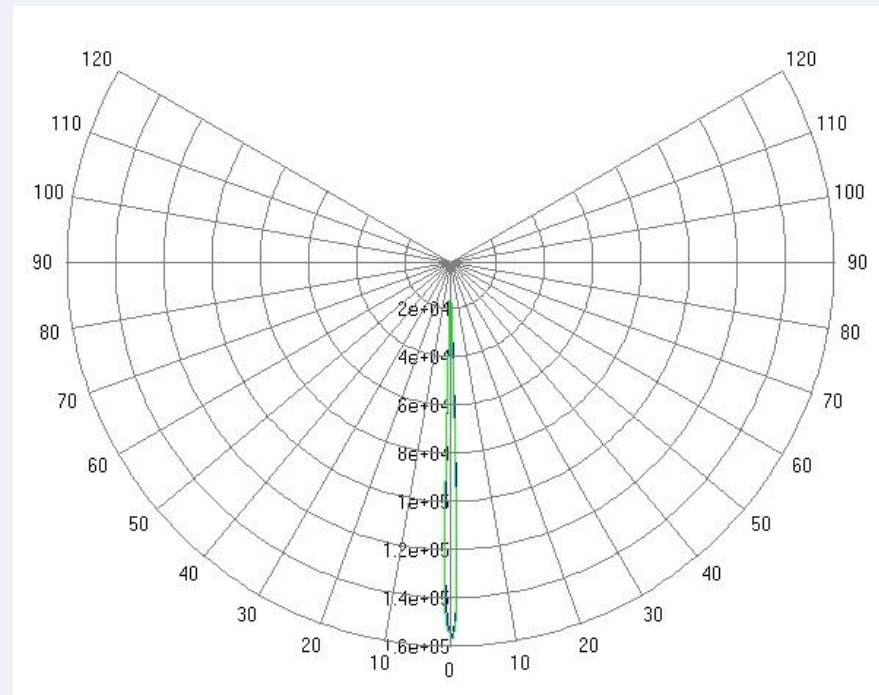

- Rectangular Candela Distribution Plot

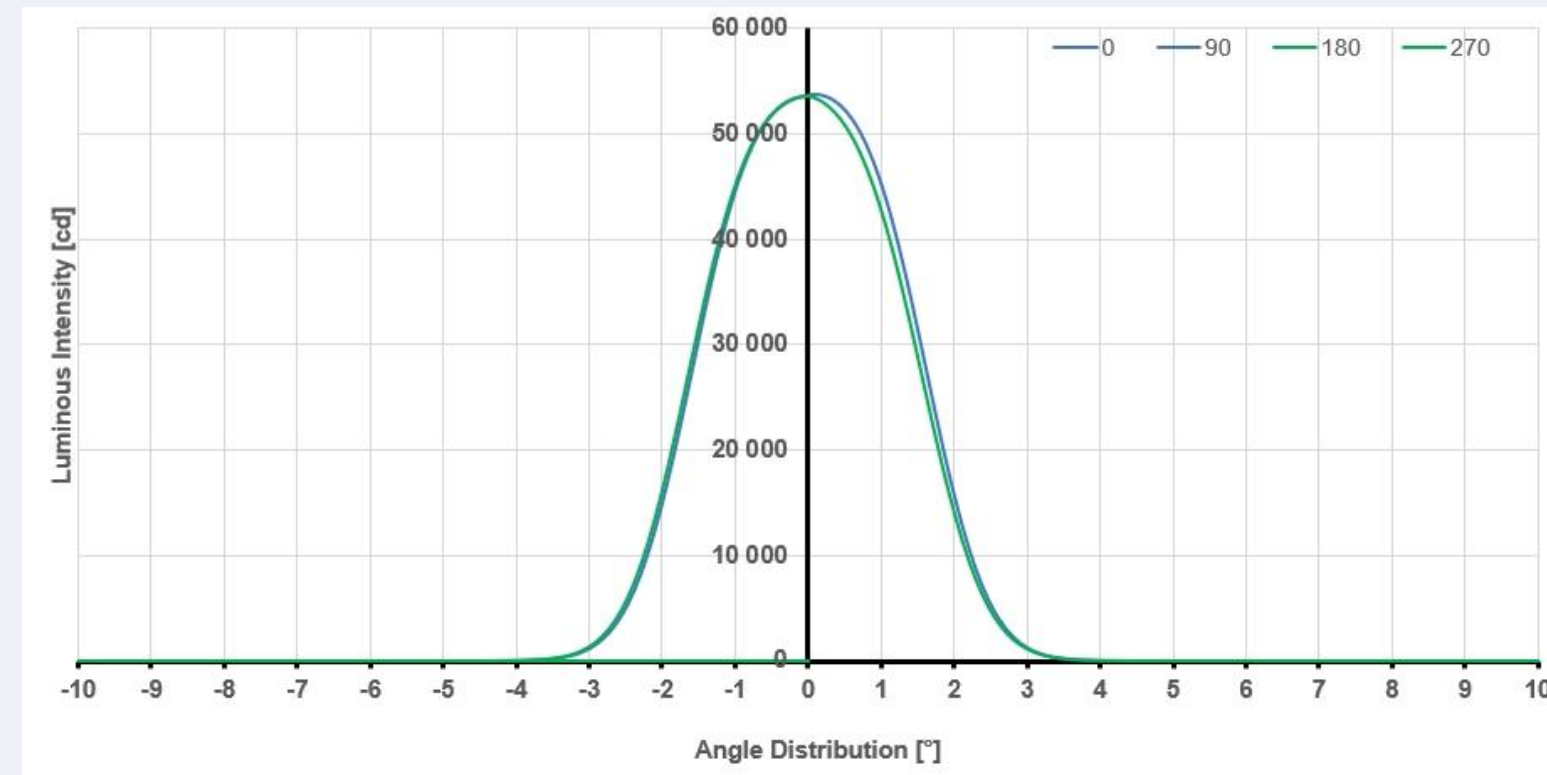

- Projection wall 3x3 m at 1m

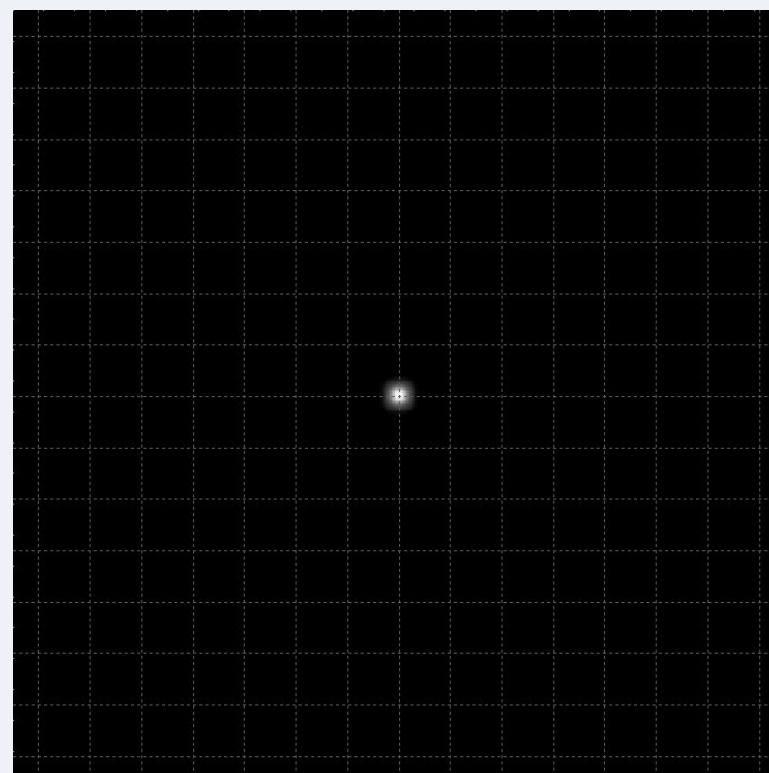

LED used for simulation	XP-G4
Luminous flux of LED [lm]	357
FWHM Co [°]	3
FWHM C90 [°]	3

* The ratio between luminous flux on the projection wall (3x3 m at 1 m) and luminous flux of LED

A650 8034

REVISION HISTORY			
REV	DESCRIPTION	DATE	APPROVED

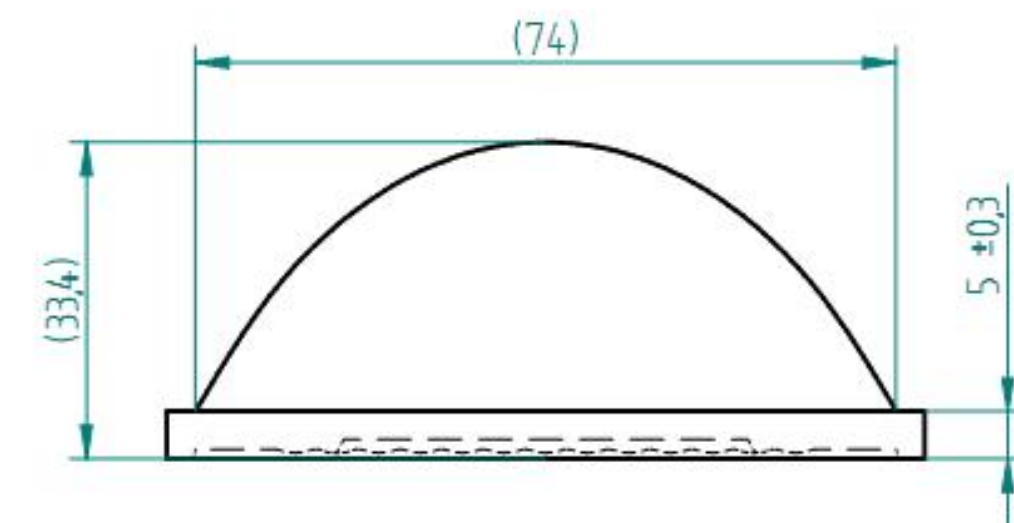
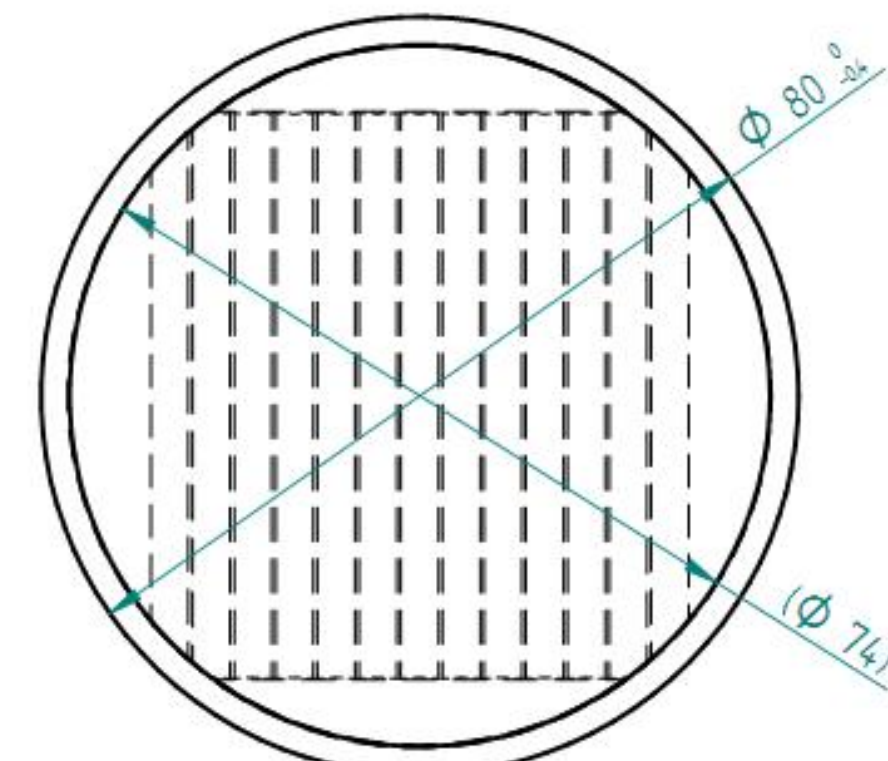
SCALE 1:2



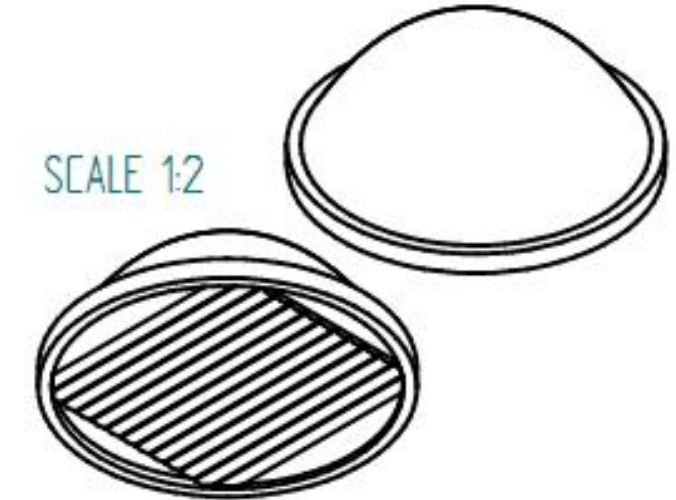
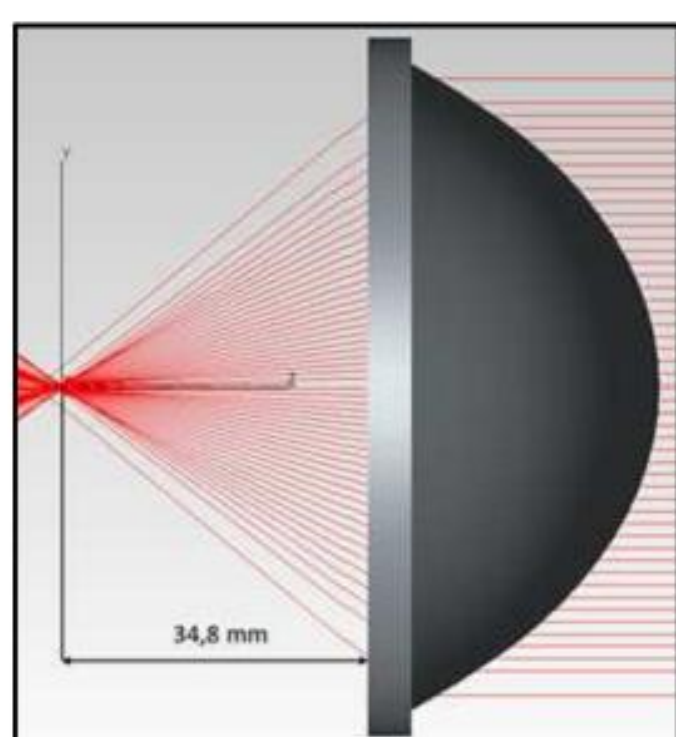

Glass: LIBA or alternative (nd = 1,521)

DRAWN	krutsky	DATE	05/29/20	 A650 8034												
CHECKED																
ENG APPR																
MER APPR																
UNLESS OTHERWISE SPECIFIED DIMENSIONS ARE IN MILLIMETERS				<table border="1" style="width: 100%; border-collapse: collapse;"> <tr> <td>SIZE</td> <td>DWG NO</td> <td>REV</td> </tr> <tr> <td>A4</td> <td> </td> <td> </td> </tr> <tr> <td>SCALE</td> <td>WEIGHT</td> <td>SHEET</td> </tr> <tr> <td> </td> <td>223 g</td> <td>1 OF 1</td> </tr> </table>	SIZE	DWG NO	REV	A4			SCALE	WEIGHT	SHEET		223 g	1 OF 1
SIZE	DWG NO	REV														
A4																
SCALE	WEIGHT	SHEET														
	223 g	1 OF 1														

A650 8034 – simulation results

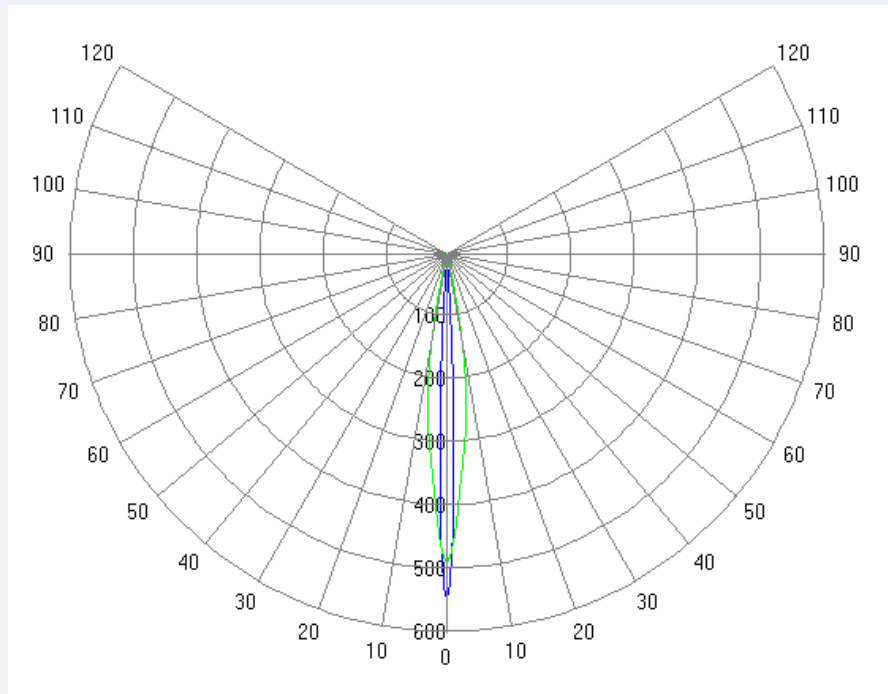
- Polar Candela Distribution Plot



- Rectangular Candela Distribution Plot

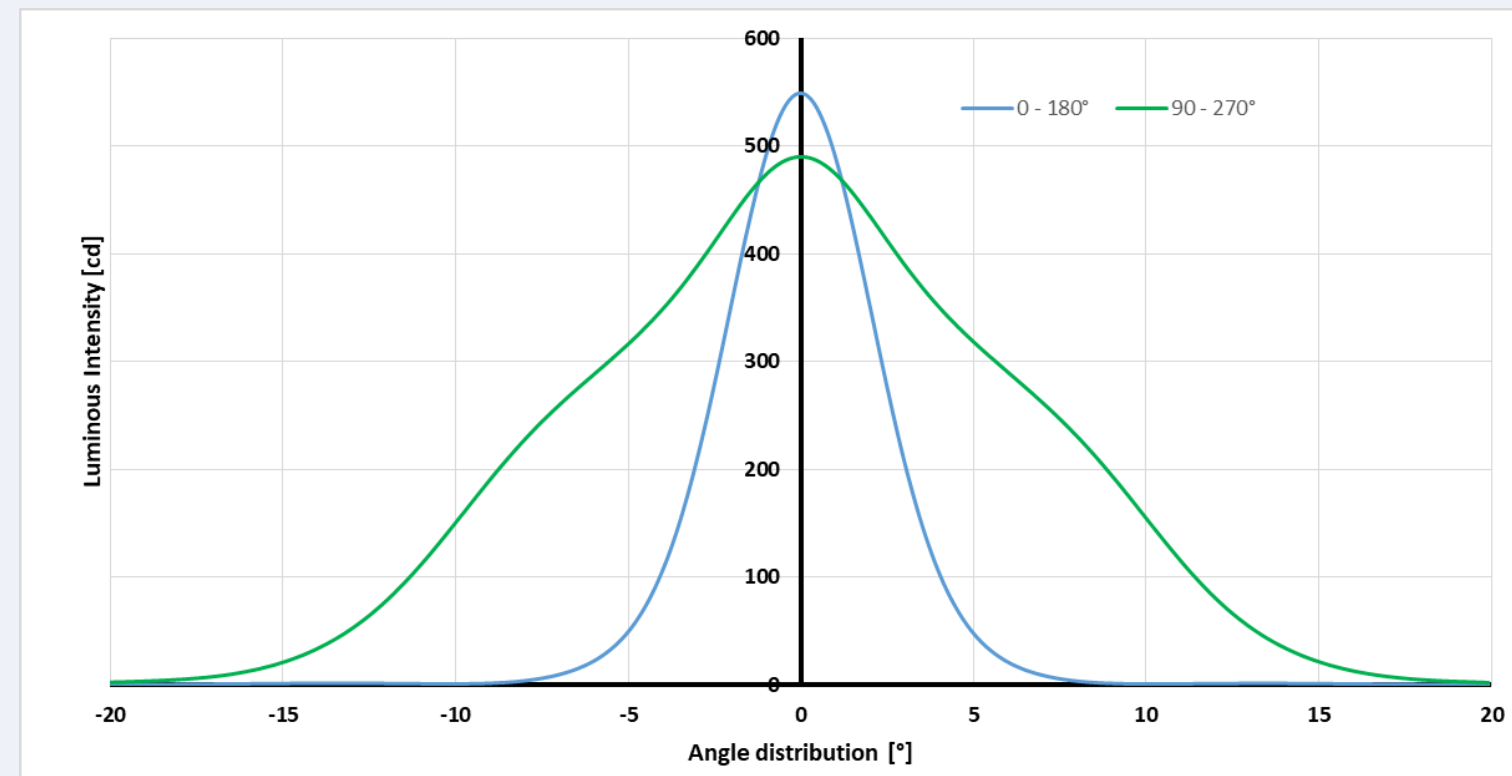

- Projection wall 3x3 m at 1m

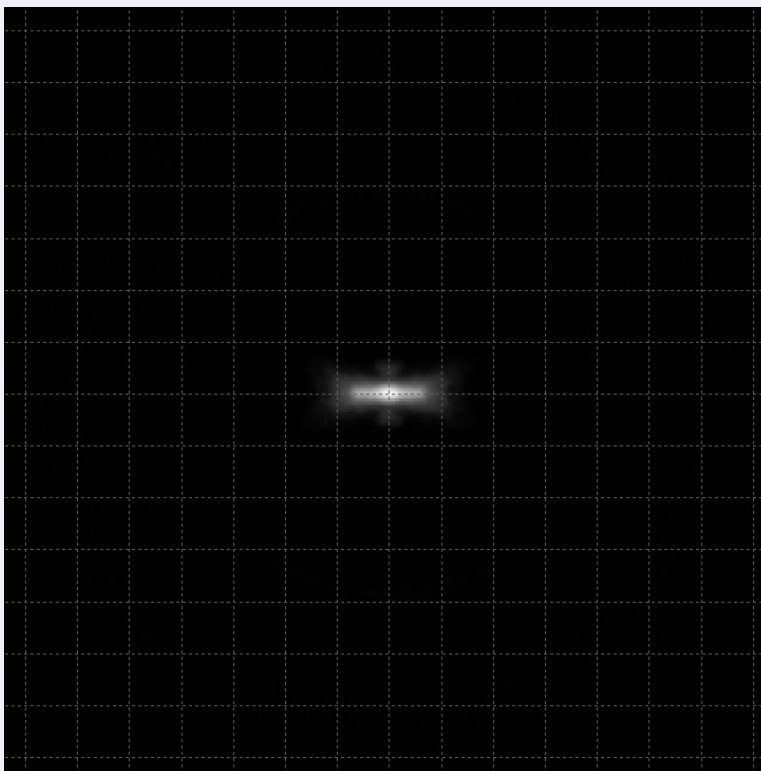

LED used for simulation	Cree XP-G
Luminous flux of LED [lm]	36
FWHM Co [°]	5
FWHM C90 [°]	15

* The ratio between luminous flux on the projection wall (3x3 m at 1 m) and luminous flux of LED

A837 3515

REVISION HISTORY			
REV	DESCRIPTION	DATE	APPROVED

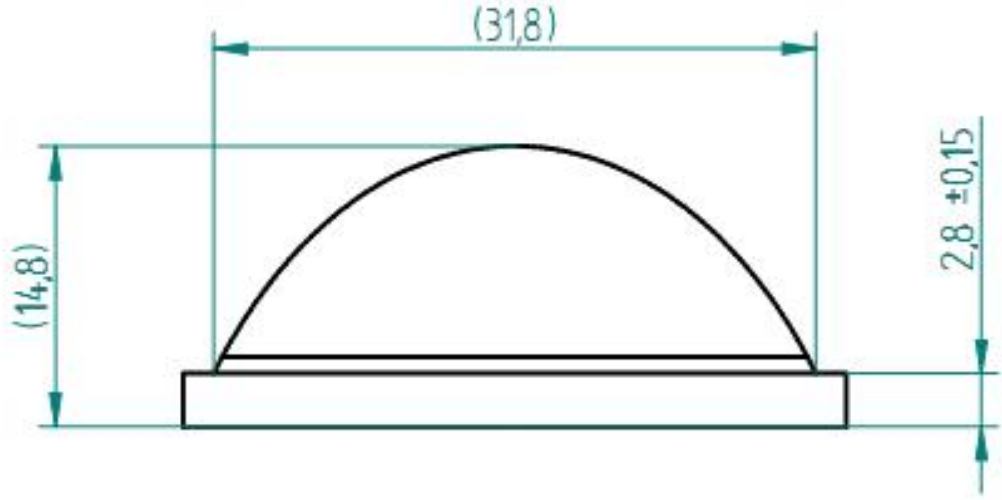
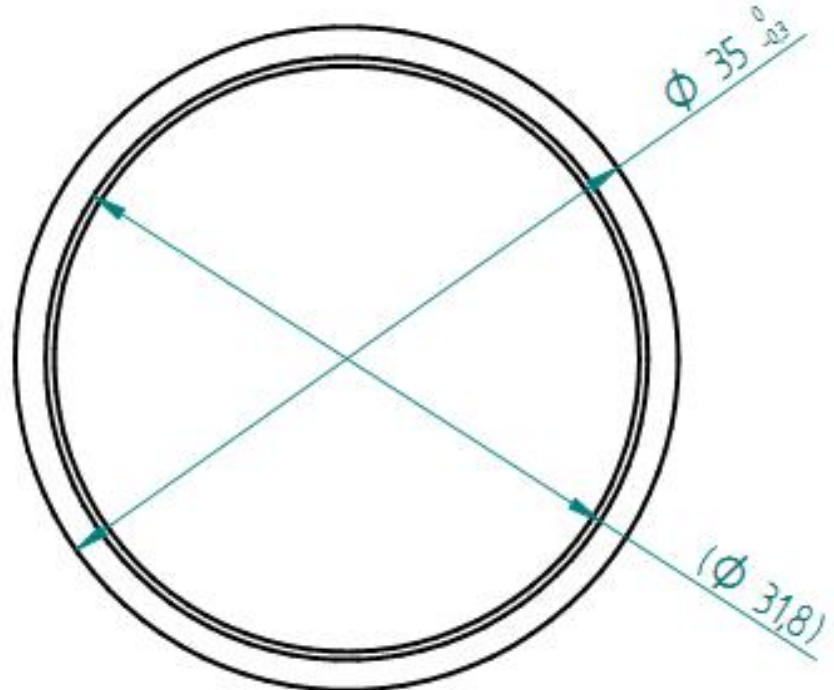
SCALE 1:1



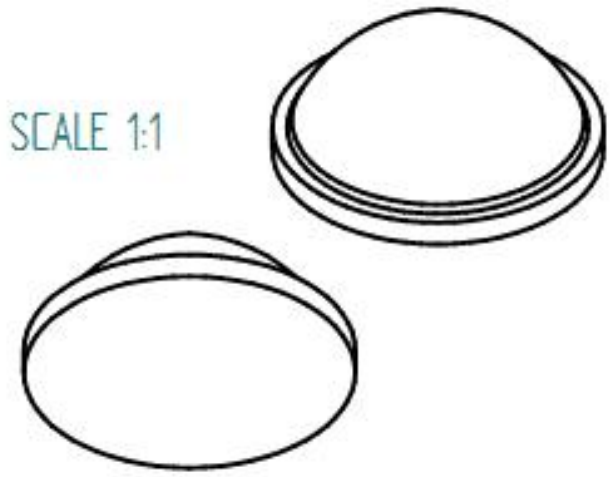
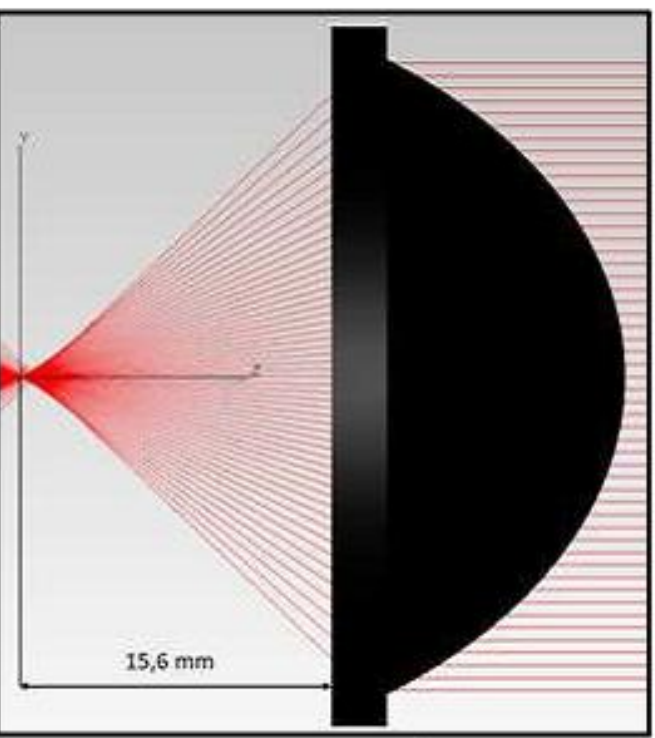

Glass: LIBA or alternative (nd = 1,521)

DRAWN	krutsky	DATE	05/28/20	 A837 3515
CHECKED				
ENG APPR				
MER APPR				
UNLESS OTHERWISE SPECIFIED DIMENSIONS ARE IN MILLIMETERS				SIZE: A4 FILE NAME: A837_small.dwg SCALE: WEIGHT: 20 g SHEET 1 OF 1

A837 3515 – simulation results

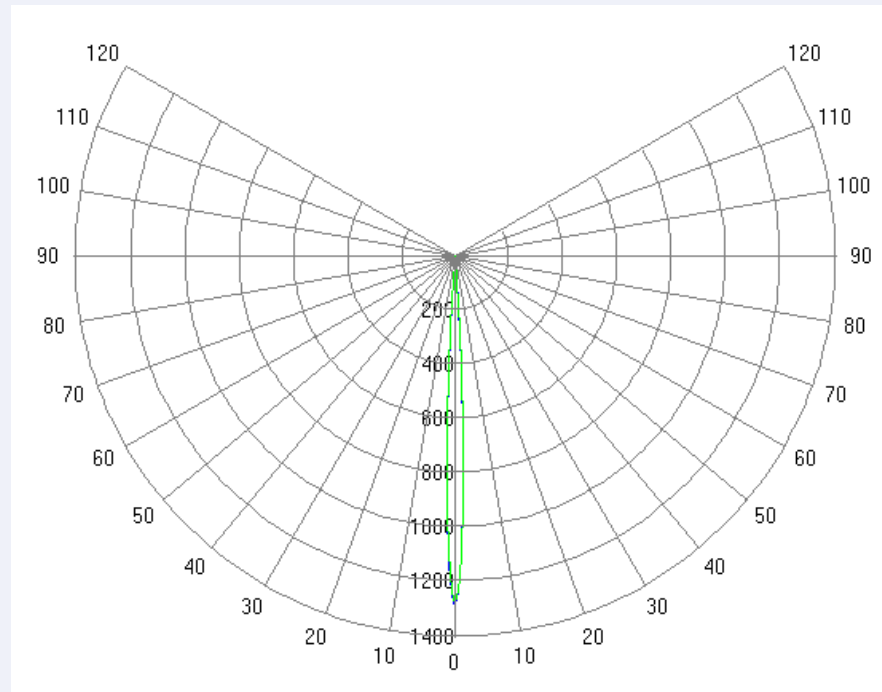
- Polar Candela Distribution Plot



- Rectangular Candela Distribution Plot

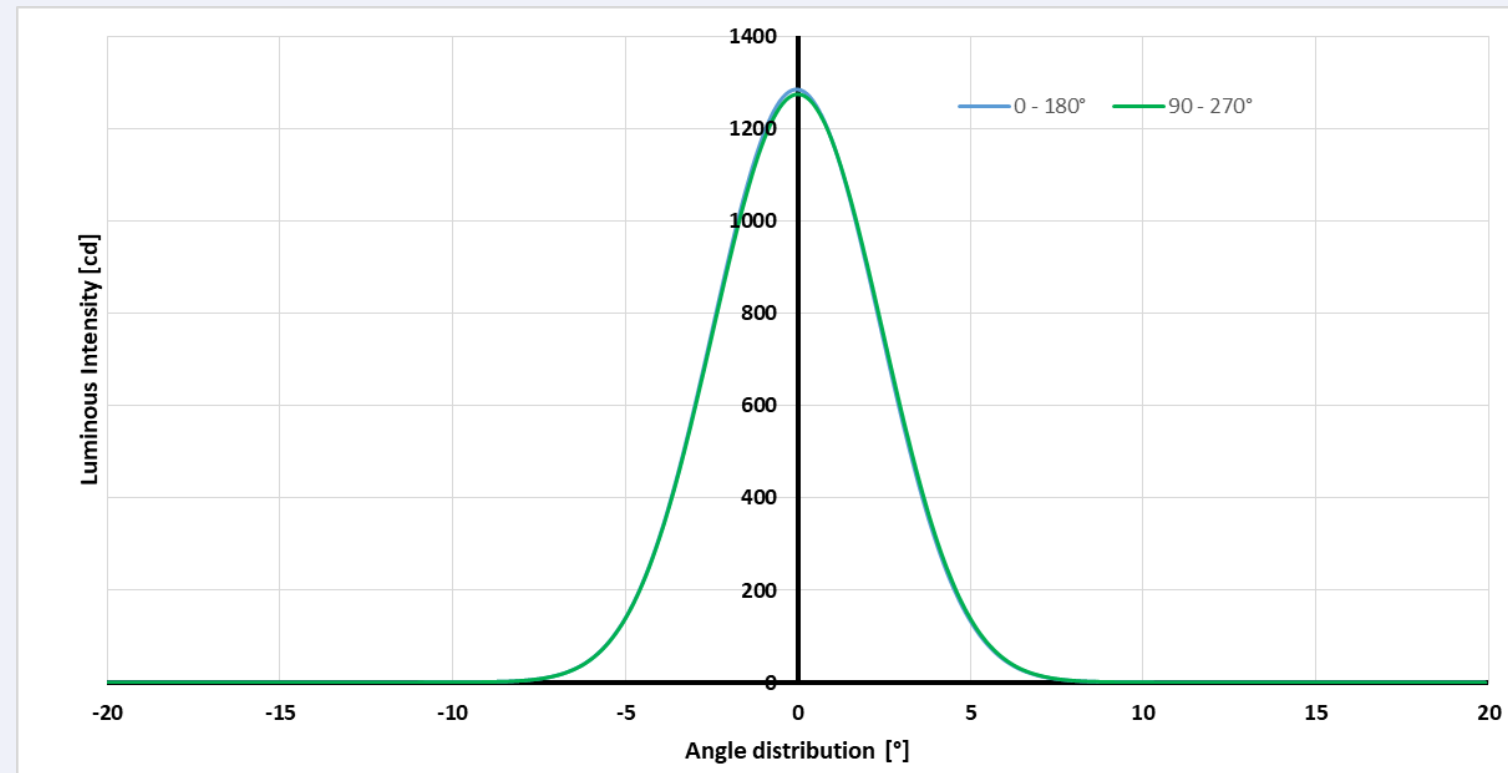

- Projection wall 5x5 m at 1m

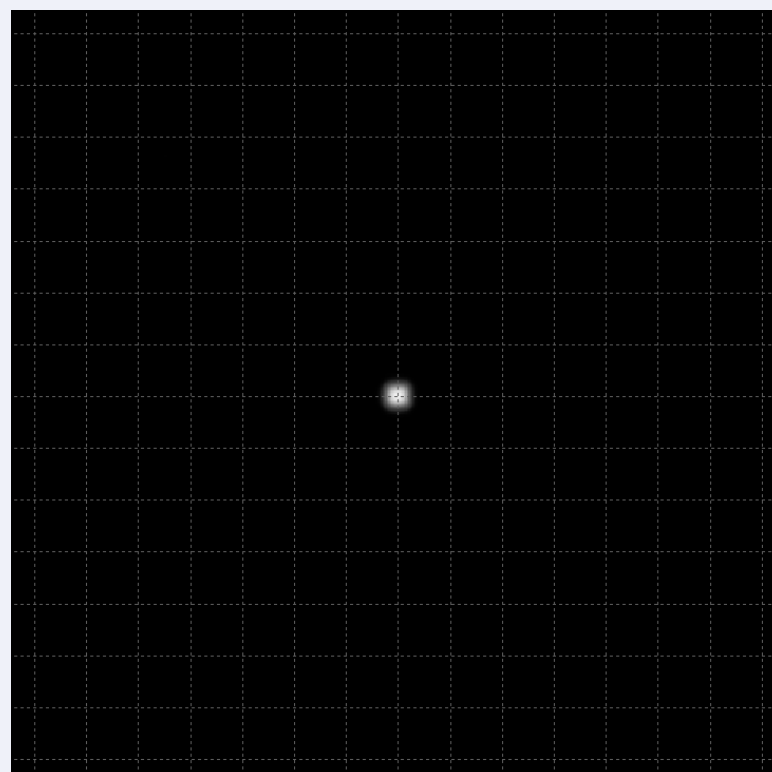

LED used for simulation	Cree XP-G
Luminous flux of LED [lm]	36
FWHM Co [°]	6
FWHM C90 [°]	6

* The ratio between luminous flux on the projection wall (5x5 m at 1 m) and luminous flux of LED

A838 1605

REVISION HISTORY			
REV	DESCRIPTION	DATE	APPROVED

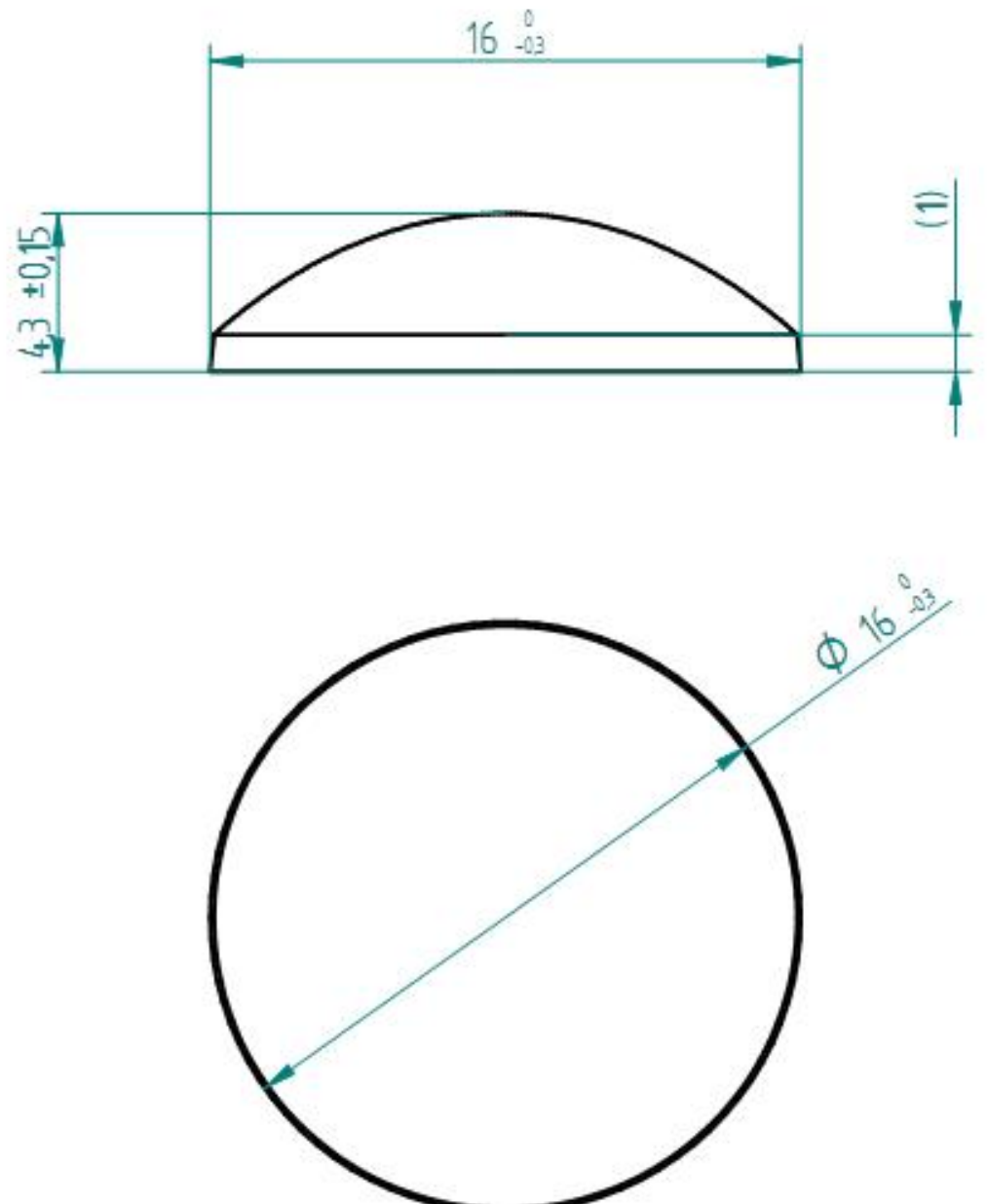

SCALE 2:1

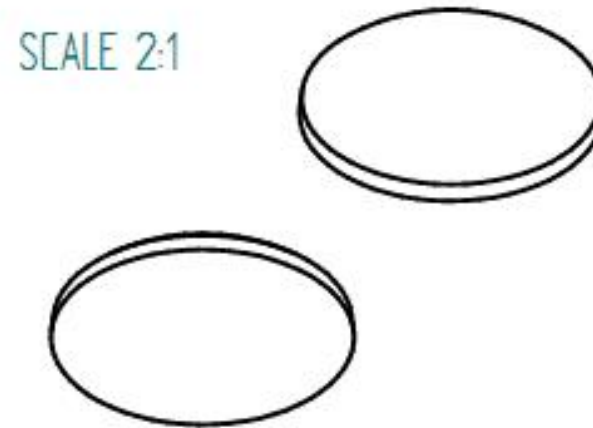

Glass: LIBA or alternative (nd = 1,521)

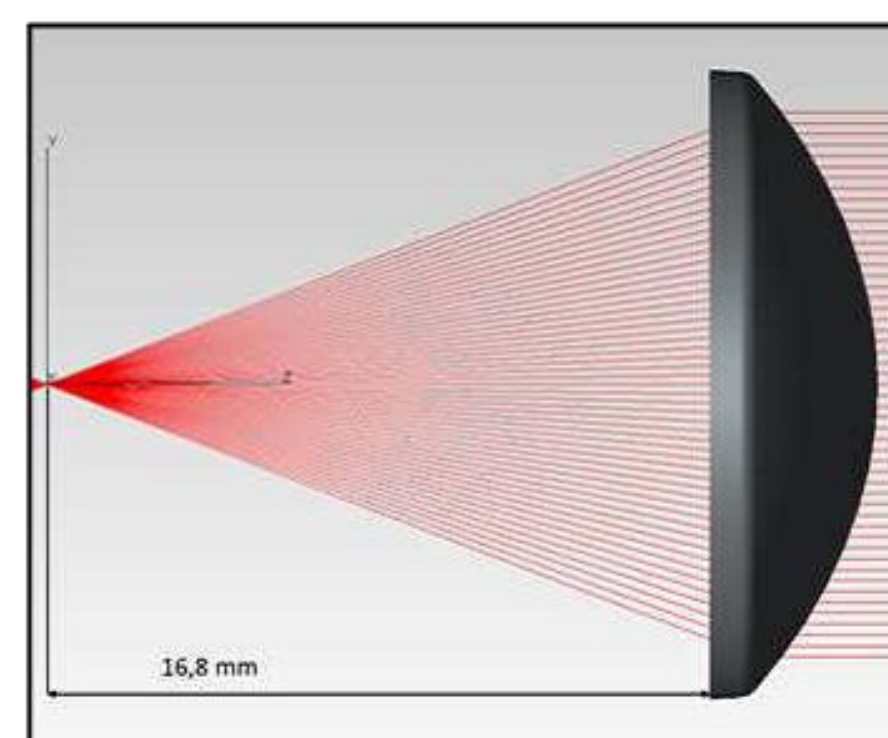

DRAWN	krutsky	DATE	05/28/20	
CHECKED				
ENG APPR				
MGR APPR				
UNLESS OTHERWISE SPECIFIED DIMENSIONS ARE IN MILLIMETERS				<p>A838 1605</p> <p>SIZE: A4 DWG NO: REV: </p> <p>FILE NAME: A838_small.dwg</p> <p>SCALE: WEIGHT: 1 g SHEET 1 OF 1</p>

A838 1605 – simulation results

- Polar Candela Distribution Plot

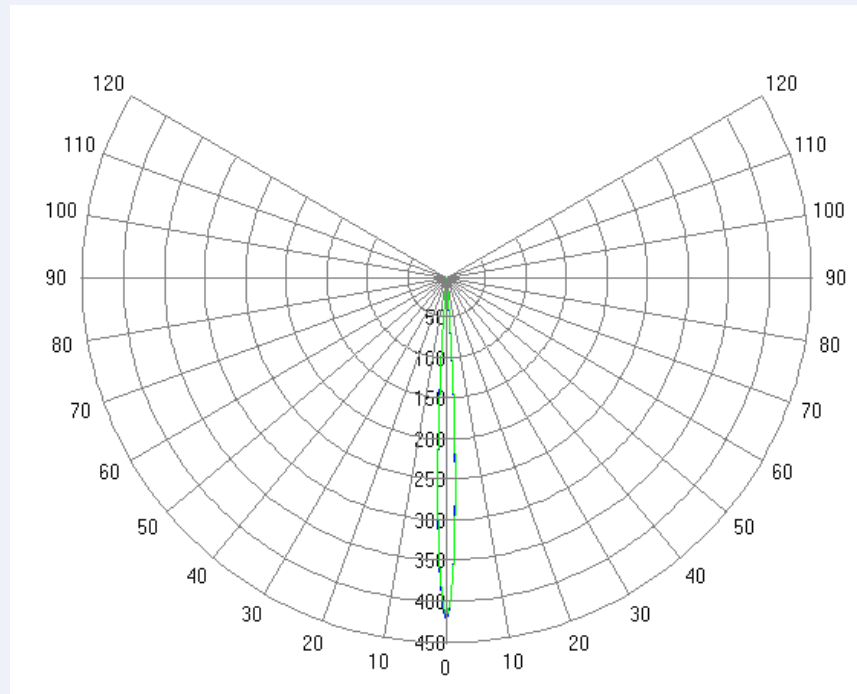

- Rectangular Candela Distribution Plot

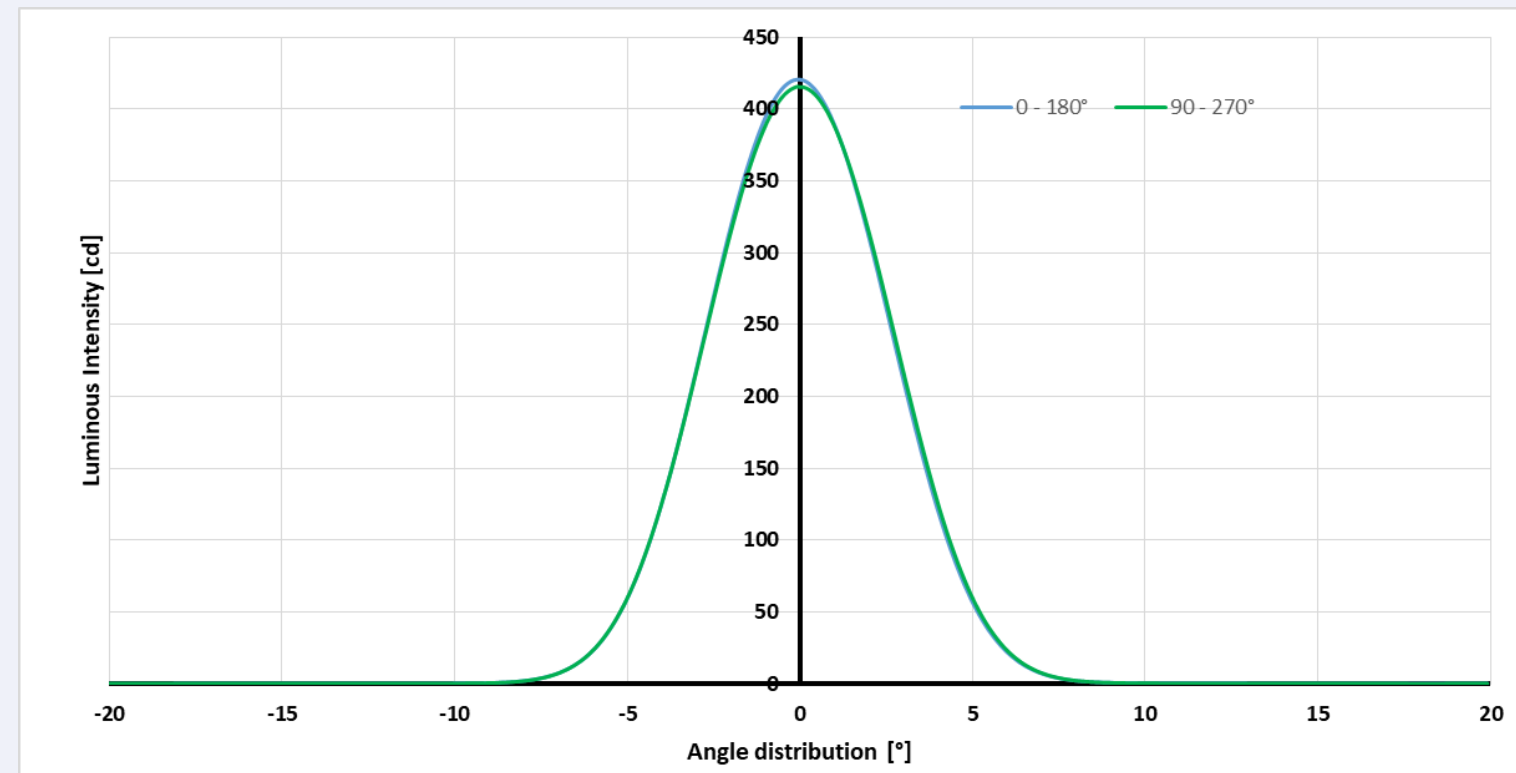

- Projection wall 5x5 m at 1m

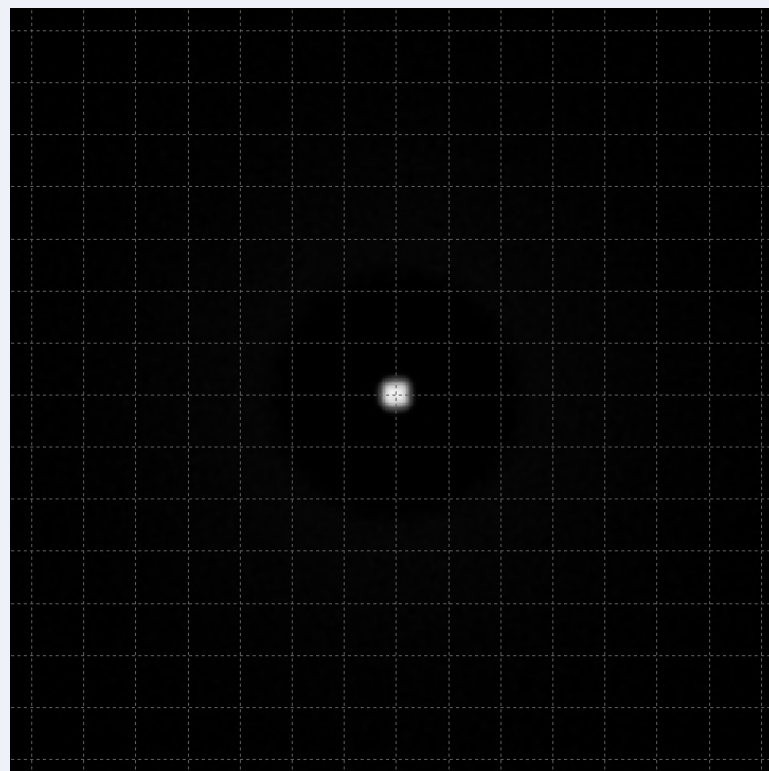

LED used for simulation	Cree XP-G
Luminous flux of LED [lm]	36
FWHM C ₀ [°]	6
FWHM C ₉₀ [°]	6

* The ratio between luminous flux on the projection wall (5x5 m at 1 m) and luminous flux of LED

A850 6315

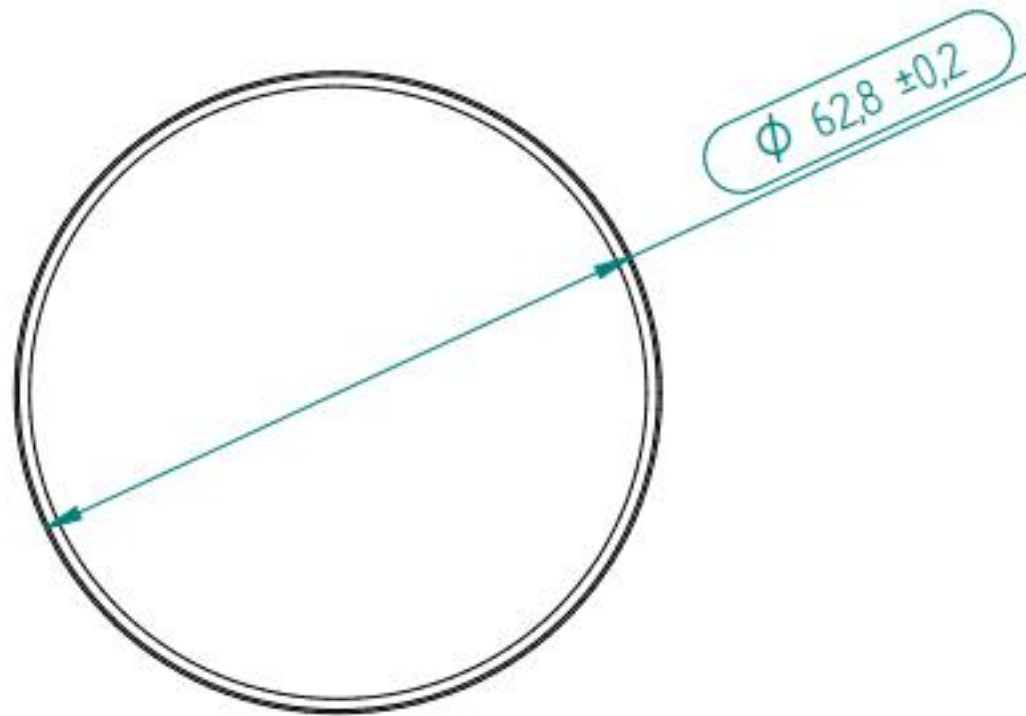
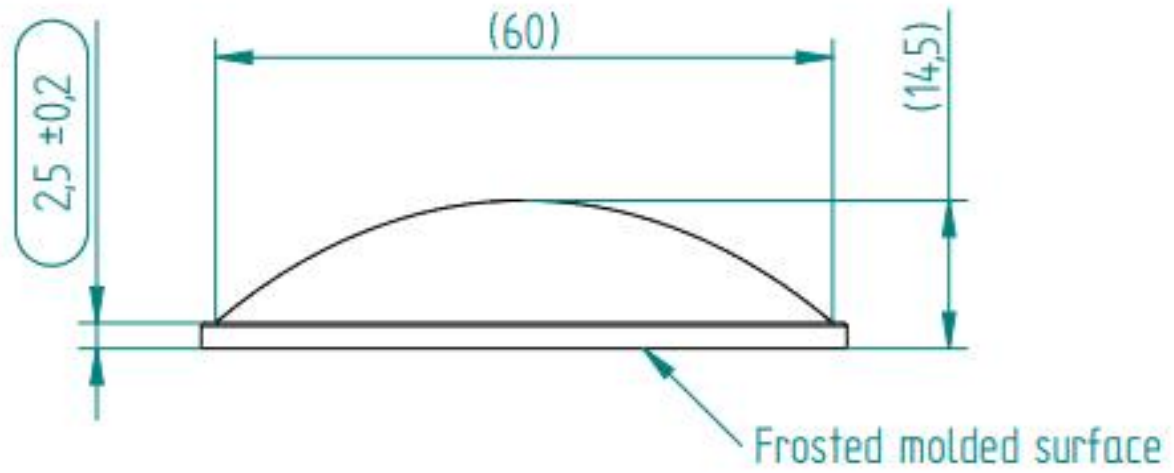

REVISION HISTORY			
REV	DESCRIPTION	DATE	APPROVED

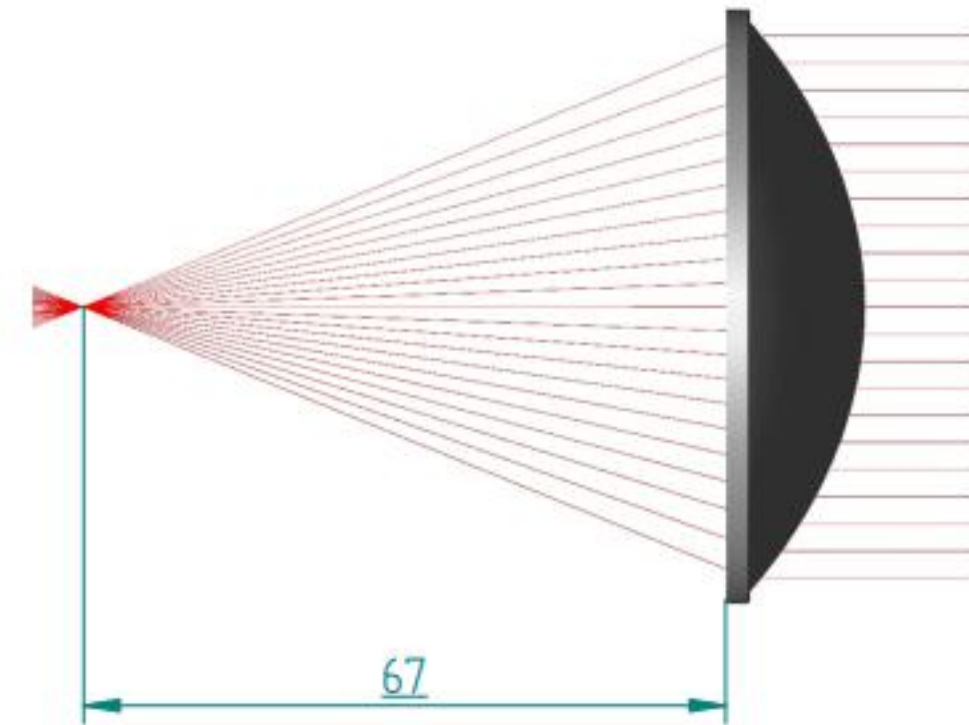

material : GLASS nd = 1,520

	NAME	DATE			
DRAWN	jkocarek	09/14/23			
CHECKED					
ENG APPR					
MGR APPR			TITLE Aspheric lens structured flat side		
UNLESS OTHERWISE SPECIFIED DIMENSIONS ARE IN MILLIMETERS ANGLES ±X.X° 2 PL ±X.XX 3 PL ±X.XXX			SIZE A4	DWG NO A850 6315	REV
			FILE NAME: A850 6315.dft		
			SCALE:	WEIGHT:	SHEET 1 OF 1

A904 4512

REVISION HISTORY			
REV	DESCRIPTION	DATE	APPROVED

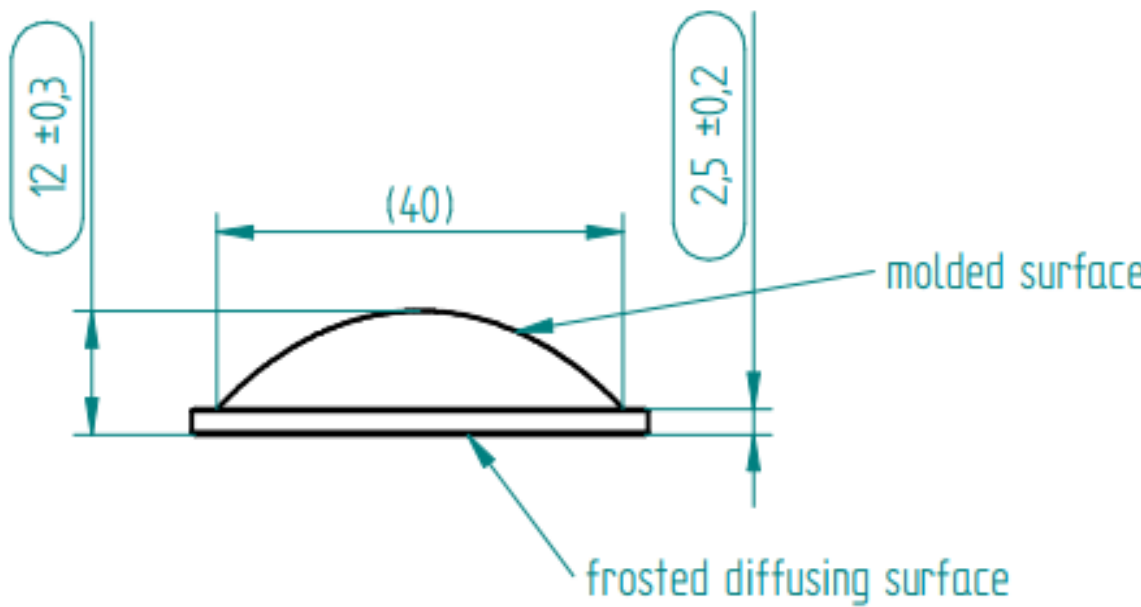

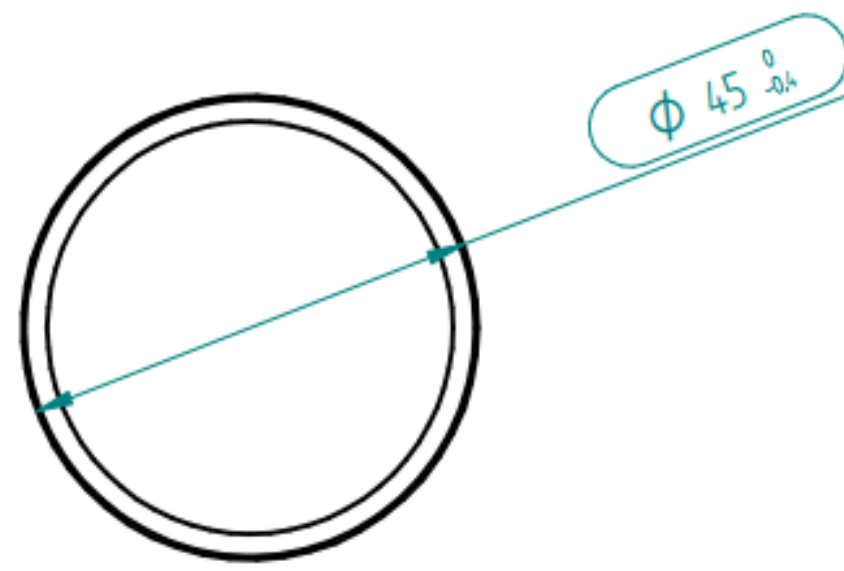

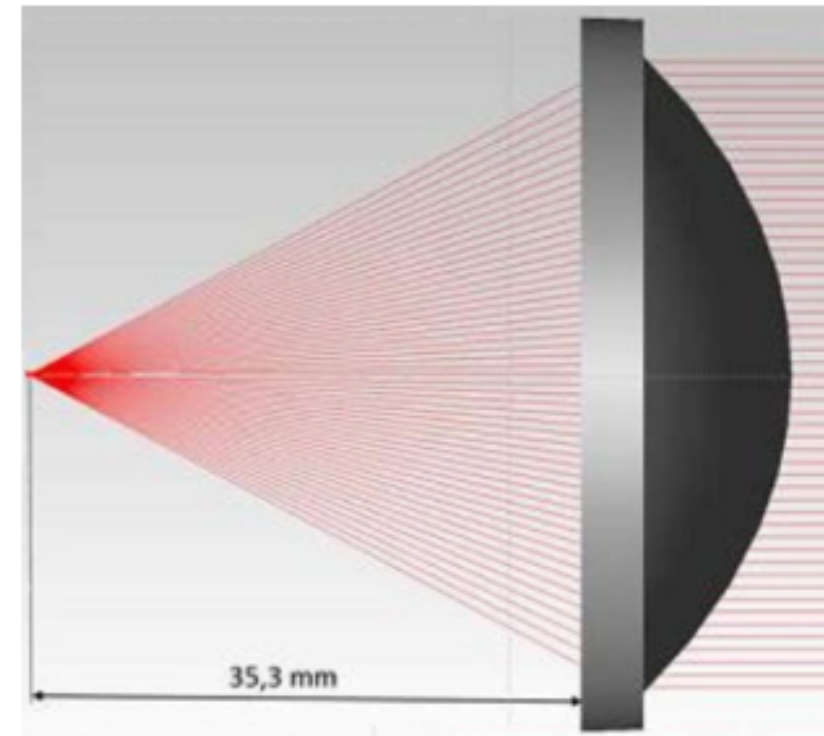

material : GLASS nd=1,520
mass: about 30g

	NAME	DATE	
DRAWN	jkocarek	03/13/23	
CHECKED			
ENG APPR			
MGR APPR			
UNLESS OTHERWISE SPECIFIED DIMENSIONS ARE IN MILLIMETERS ANGLES ±X.X° 2 PL ±X.XX 3 PL ±X.XXX			TITLE Aspheric Lens D45BF35 frosted
SIZE	DWG NO	REV	
A4	A904 4512	AP01	
FILE NAME: A904 4512.dft			
SCALE:	WEIGHT:	SHEET 1 OF 1	

A912 5225

REVISION HISTORY			
REV	DESCRIPTION	DATE	APPROVED

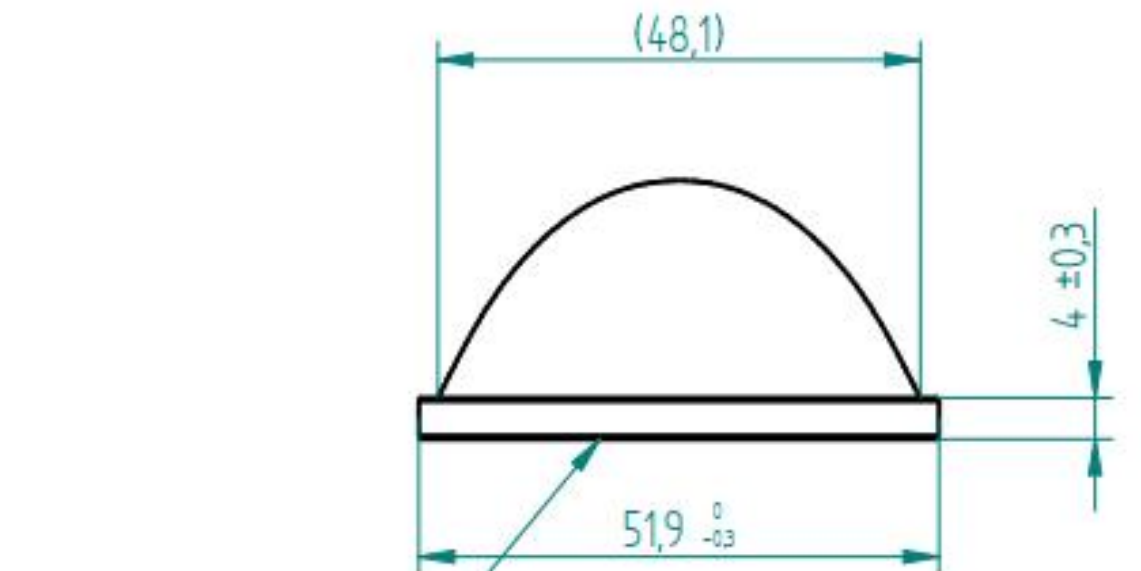

frosted surface

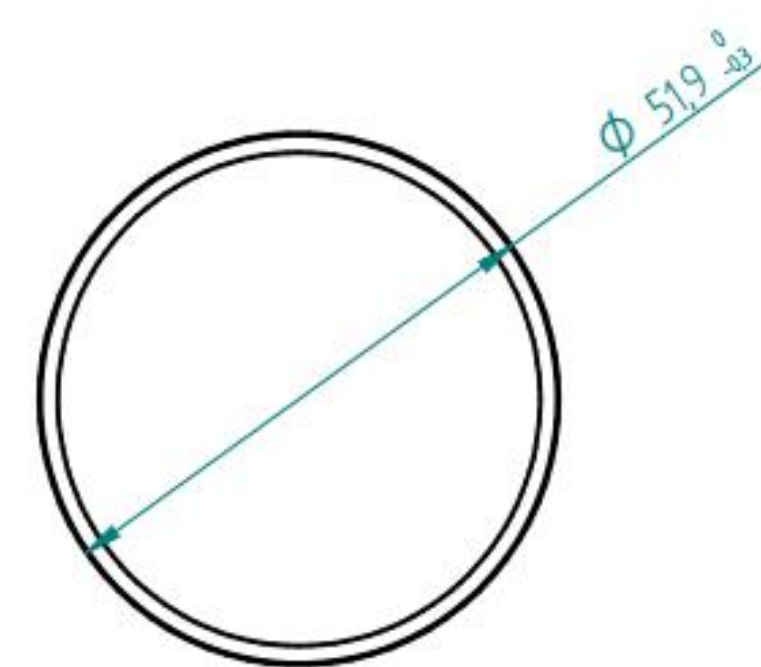

SCALE 1:2

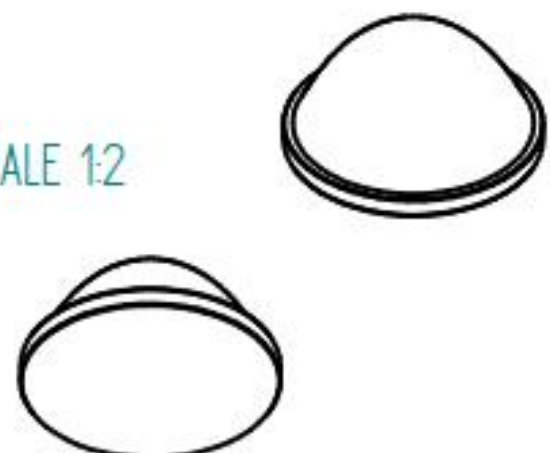

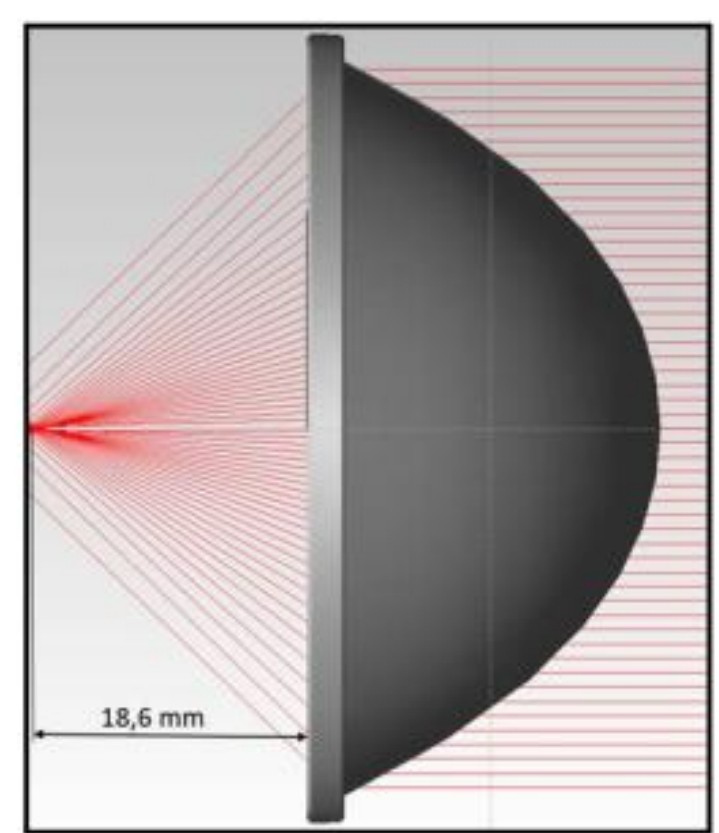

Glass: LIBA or alternative (nd = 1,521)

DRAWN	krutsky	DATE	07/15/23
CHECKED			
ENG APPR			
MGR APPR			



ECOGLOSS

A912 5225

UNLESS OTHERWISE SPECIFIED DIMENSIONS ARE IN MILLIMETERS	SEC AL	DWG NO	REV
SCALE:	WEIGHT:	75 g	SHEET 1 OF 1

ECOGLOSS TIR Lenses					
ECOGLOSS code	Lens type	Beam angles FWHM (°) *		Diameter (mm)	Thickness (mm)
		Co (0°)	C90 (90°)		
A469 CE	Collimator	20	40	27,0	16,3
A470 C10	Collimator	10	10	27,0	19,3
A471 C40	Collimator	40	40	27,0	14,8
A492 C40	Collimator	40	40	27,0	15,2
A493 C40	Collimator	50	50	27,0	19,8
A559 5631	Collimator	6,5	6,5	56,0	30,8
A561 7041	Collimator	5,6	5,6	70,0	41,0
A562 3929	Collimator	7,8	7,8	39,0	26,0
A643 C20	Collimator	20	20	27,0	16,4



A469 CE

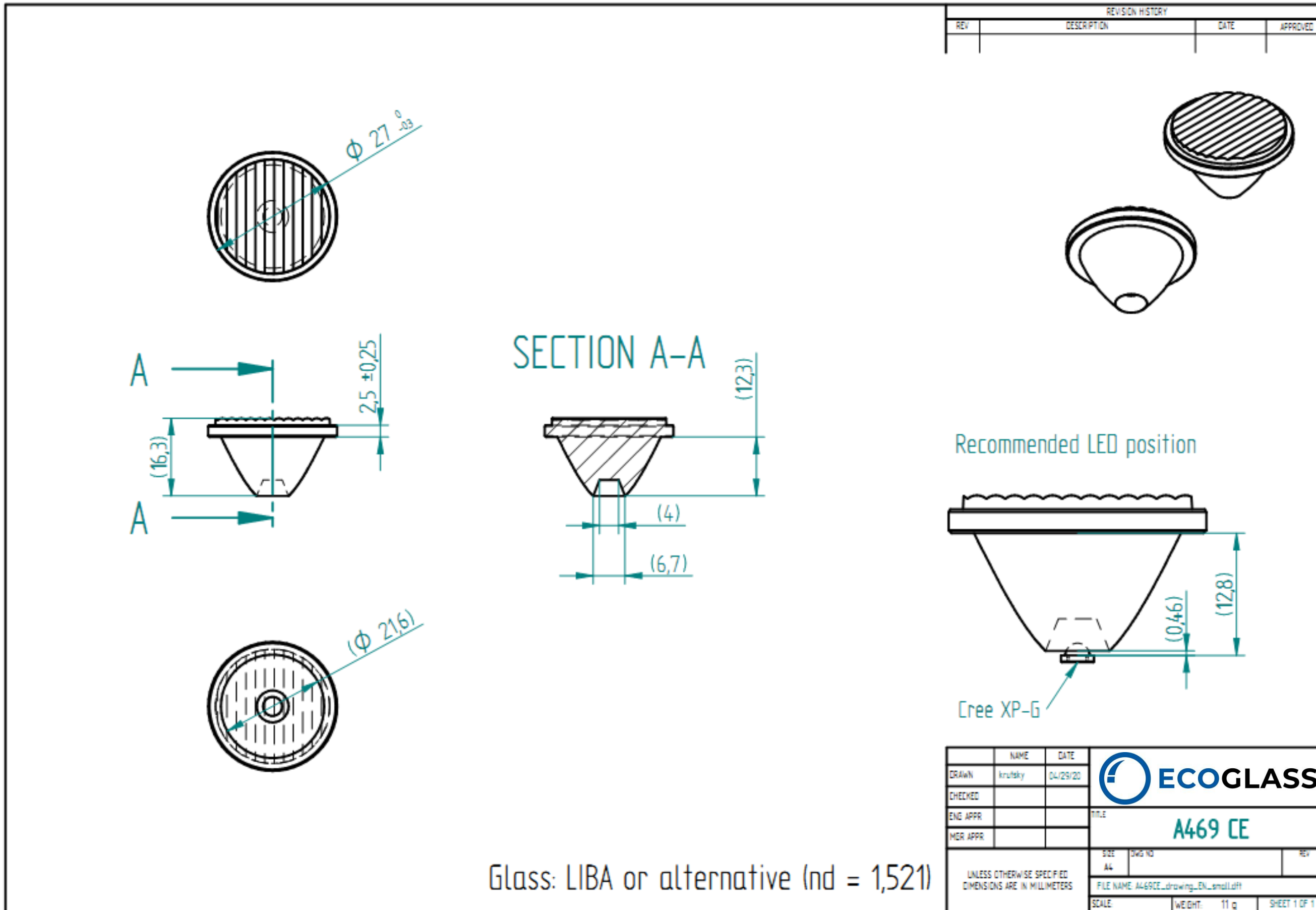

Glass: LIBA or alternative (nd = 1,521)

A46g CE- simulation results

- Polar Candela Distribution Plot

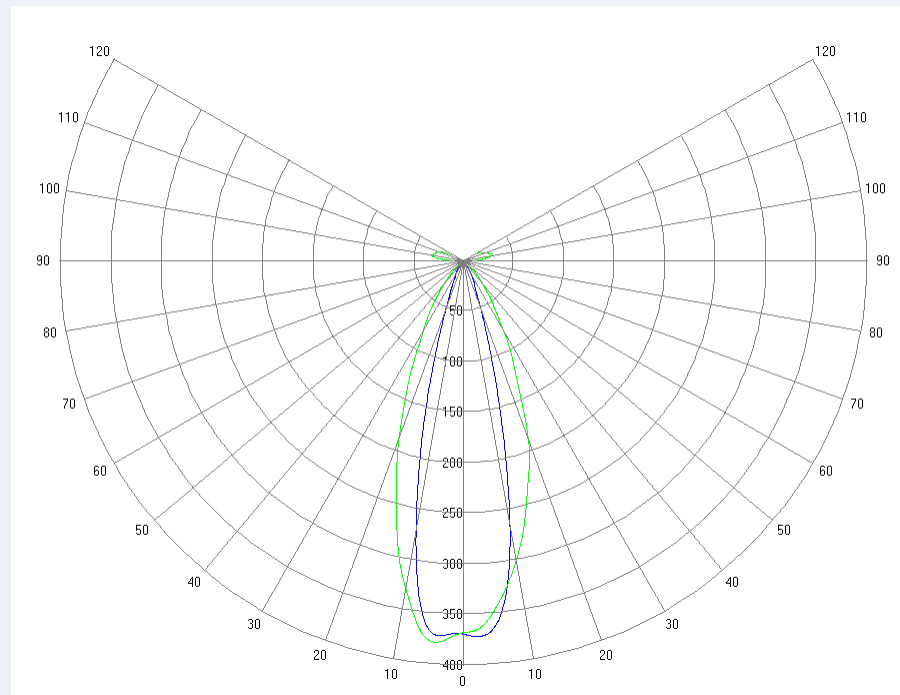

- Rectangular Candela Distribution Plot

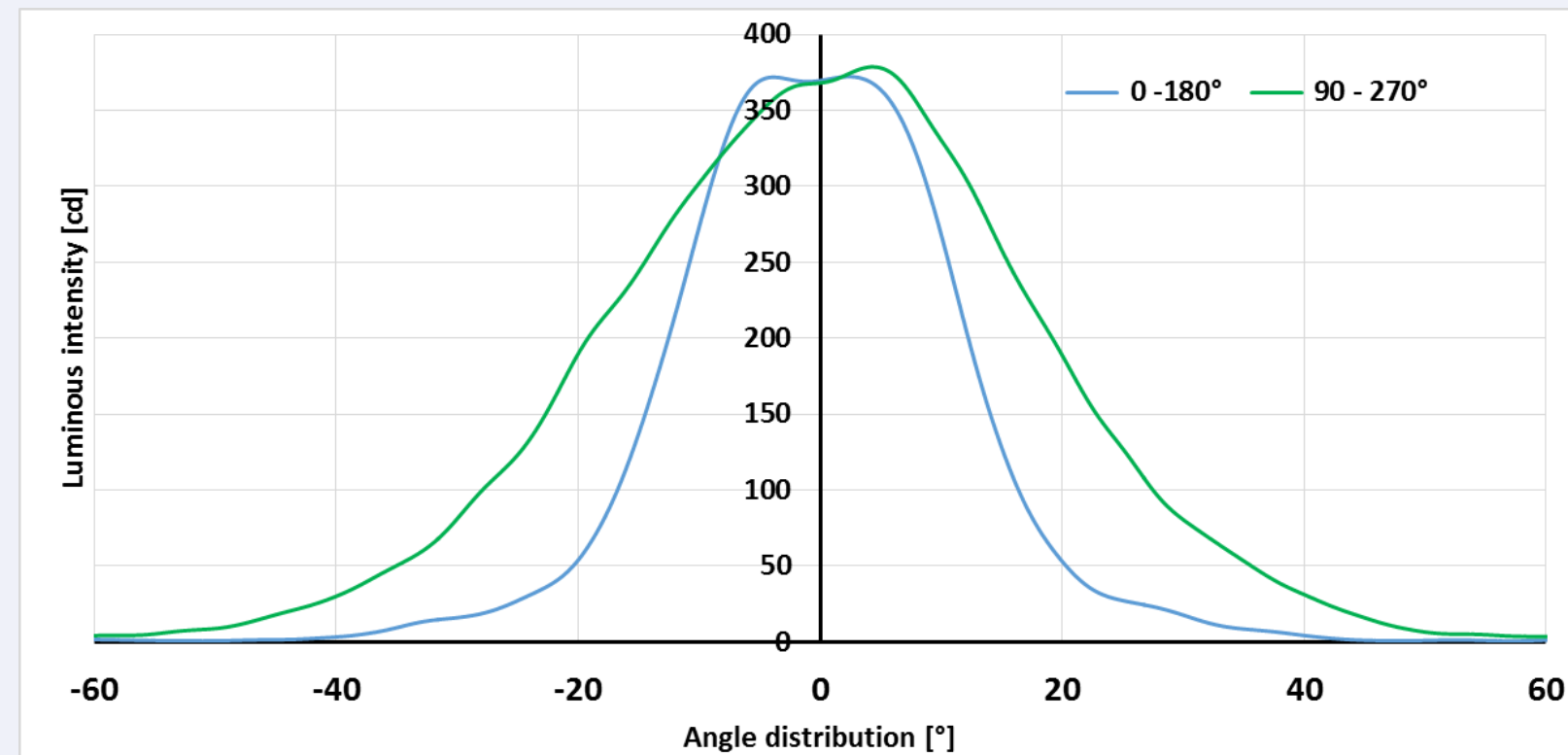

- Projection wall 3x3 m at 1m

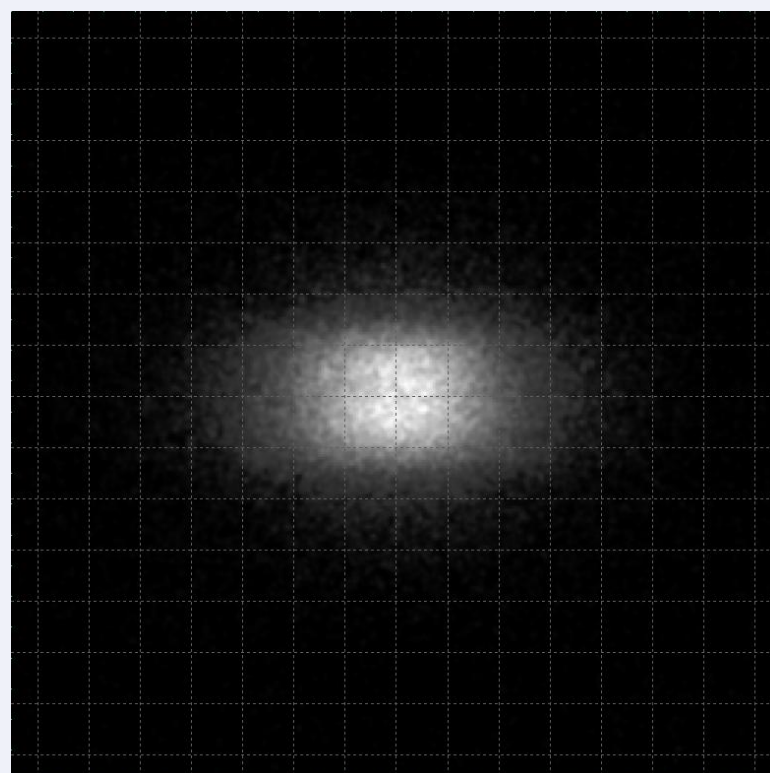

LED used for simulation	Cree XP-G
Luminous flux of LED [lm]	36
Efficiency [%]*	81
FWHM Co [°]	20
FWHM C90 [°]	40

* The ratio between luminous flux on the projection wall (3x3 m at 1 m) and luminous flux of LED

A470 C10

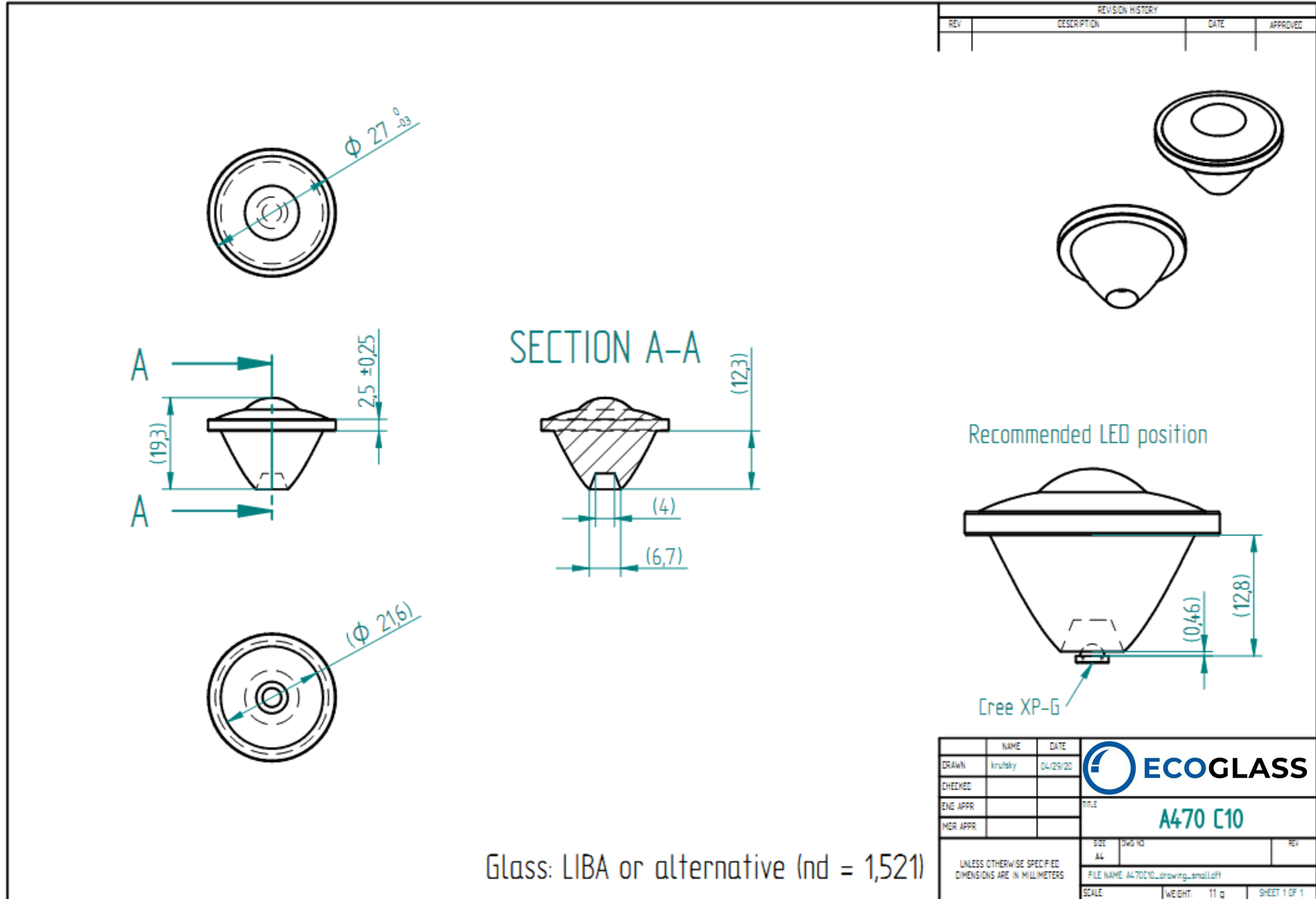

A470 C10- simulation results

- Polar Candela Distribution Plot

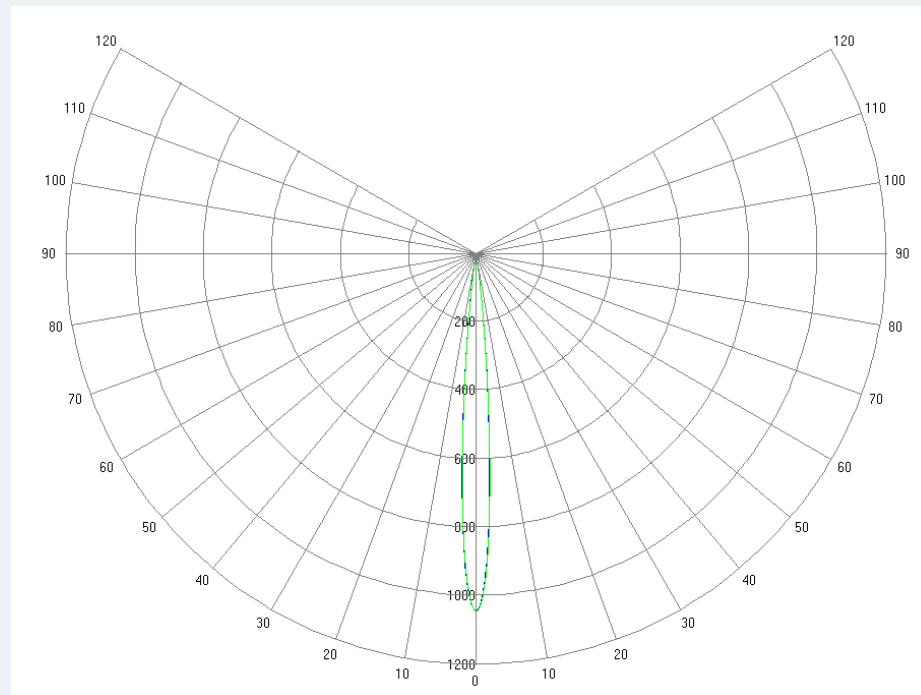

- Rectangular Candela Distribution Plot

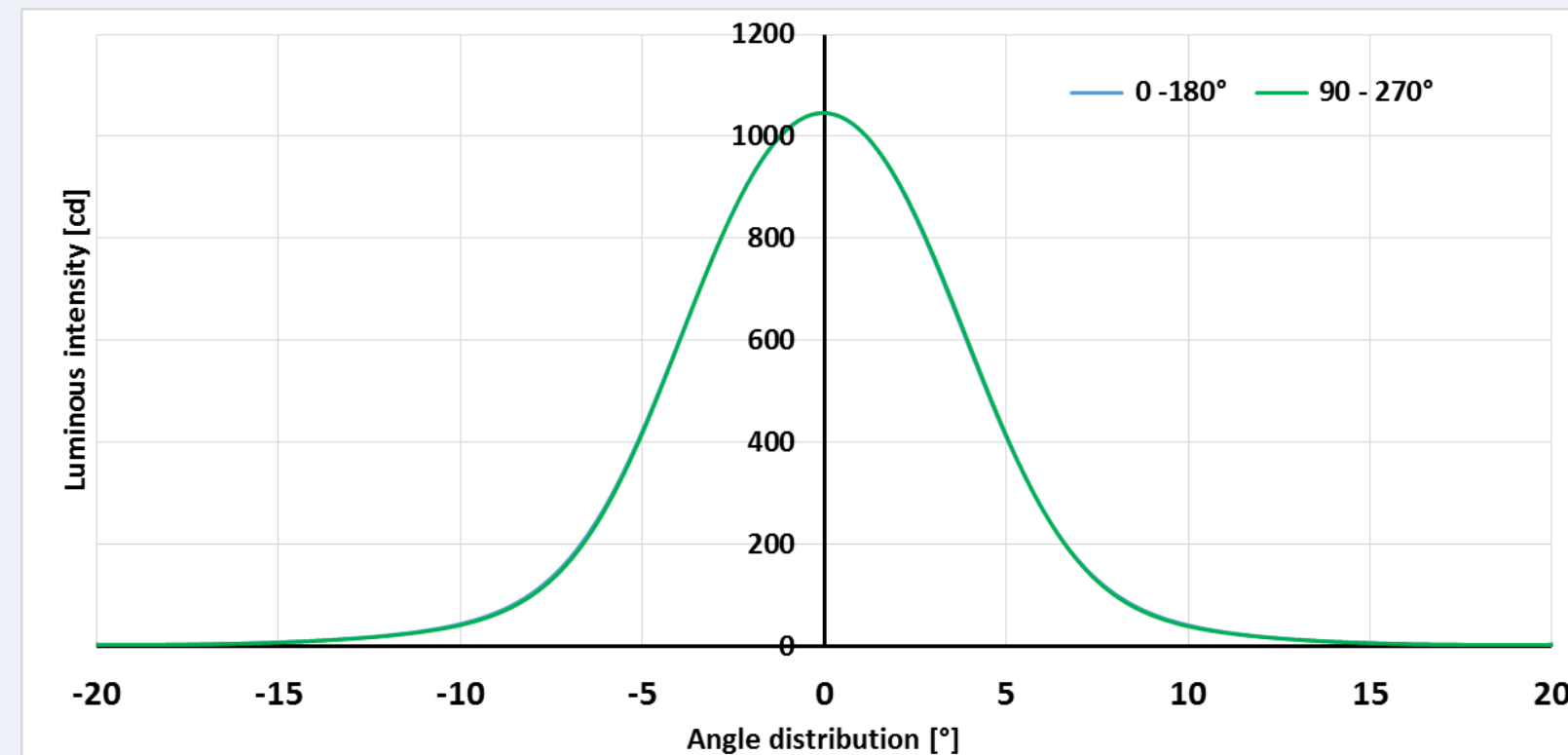

- Projection wall 3x3 m at 1m

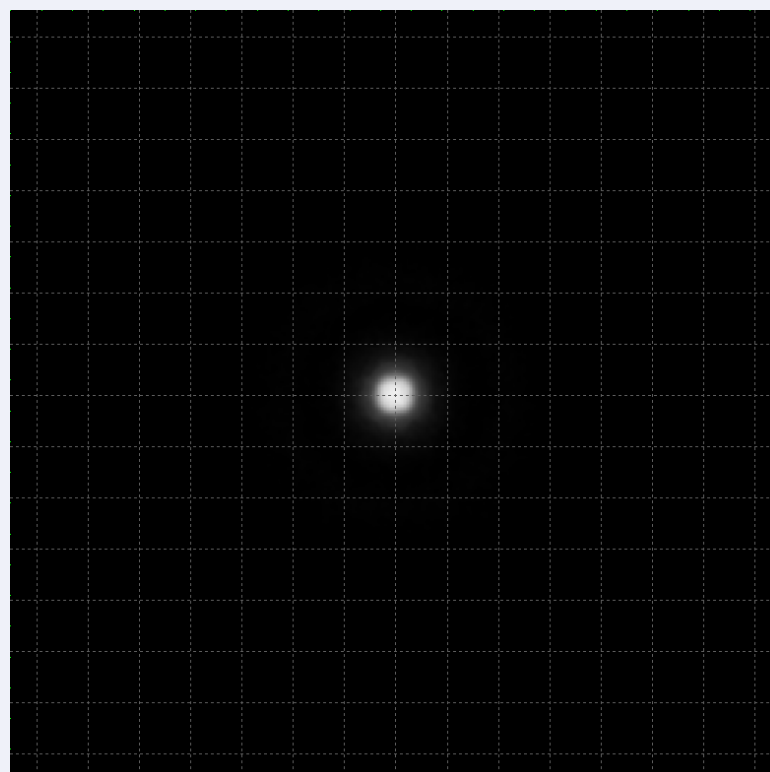

LED used for simulation	Cree XP-G
Luminous flux of LED [lm]	36
Efficiency [%]*	87
FWHM Co [°]	10
FWHM C90 [°]	10

* The ratio between luminous flux on the projection wall (3x3 m at 1 m) and luminous flux of LED

A471 C40

REVISION HISTORY			
REV	DESCRIPTION	DATE	APPROVE

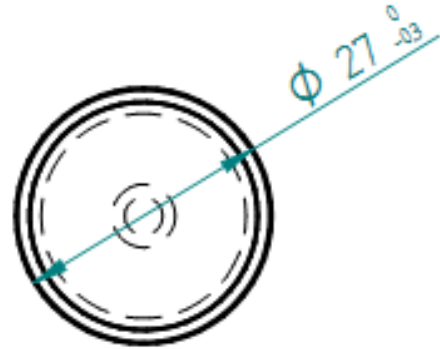
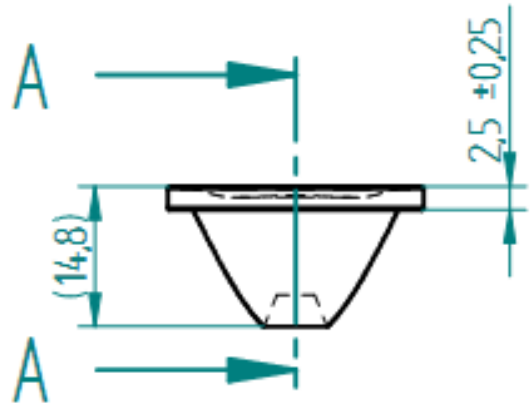
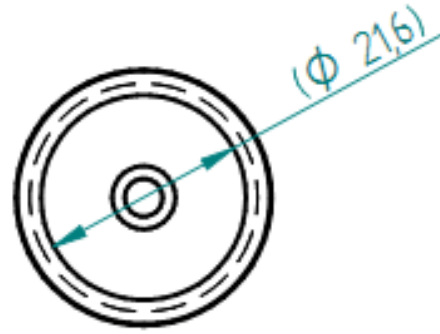

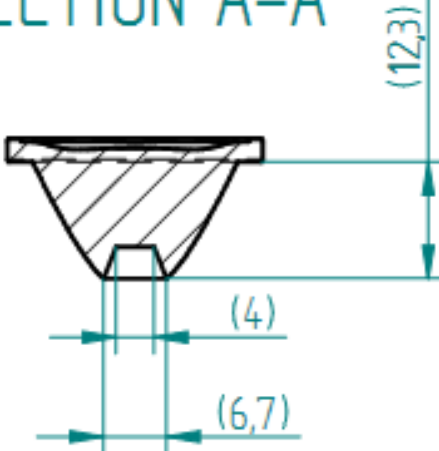

SECTION A-A

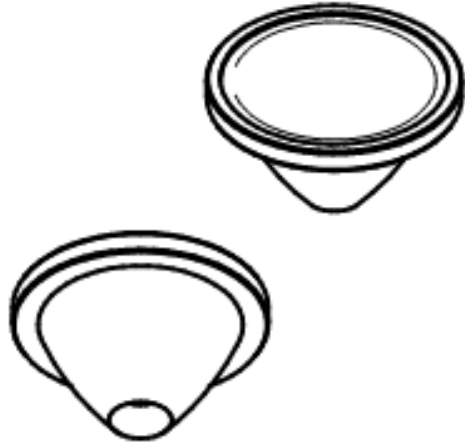

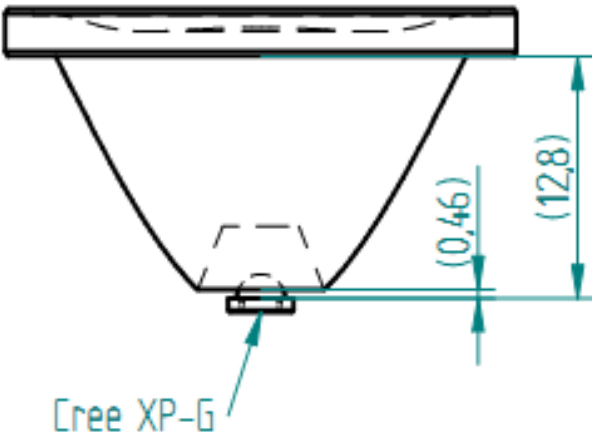

Recommended LED position



Glass: LIBA or alternative (nd = 1,521)

DRAWN	krutsky	DATE	04/29/20	 ECOGLOSS
CHECKED				
ENG. APPR.				
MGR. APPR.				
UNLESS OTHERWISE SPECIFIED DIMENSIONS ARE IN MILLIMETERS				A471 C40
SIZE	A4	DWG. NO.		REV.
SCALE		FILE NAME	A471w40 Husko_EN_small.dwg	
		WEIGHT	9 g	SHEET 1 OF 1

A471 C40- simulation results

- Polar Candela Distribution Plot

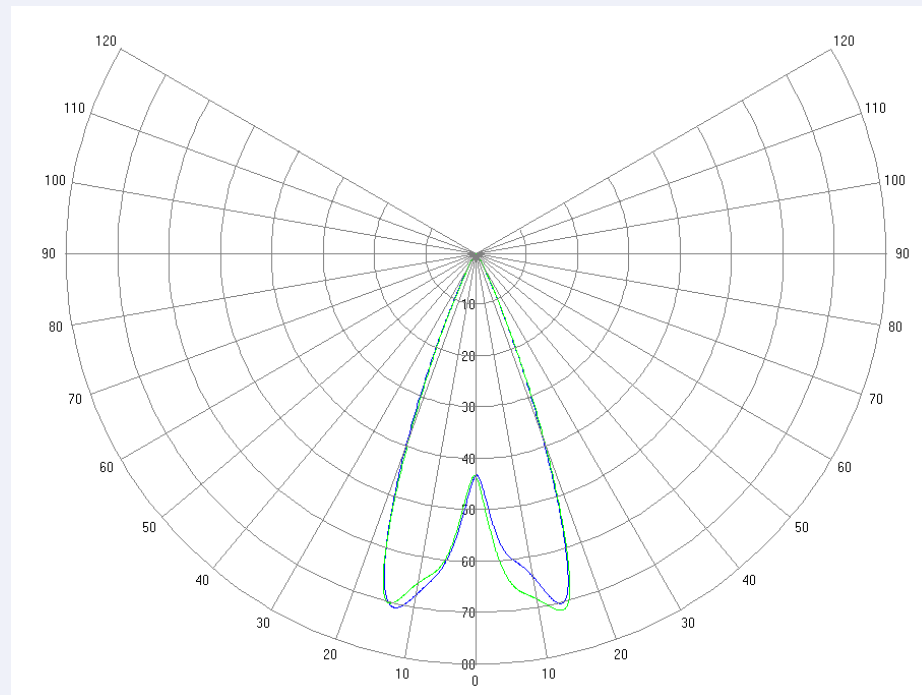

- Rectangular Candela Distribution Plot

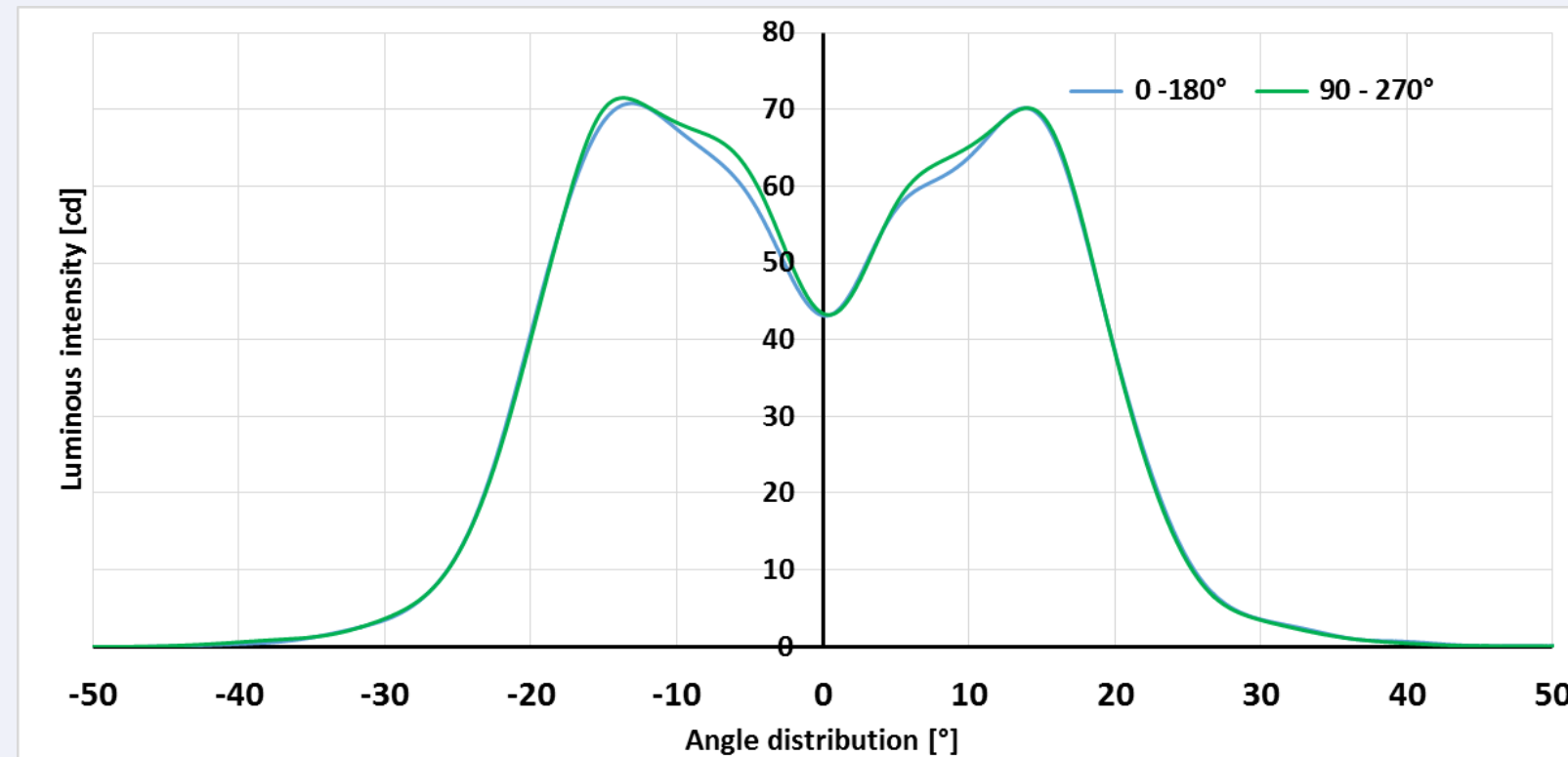

- Projection wall 3x3 m at 1m

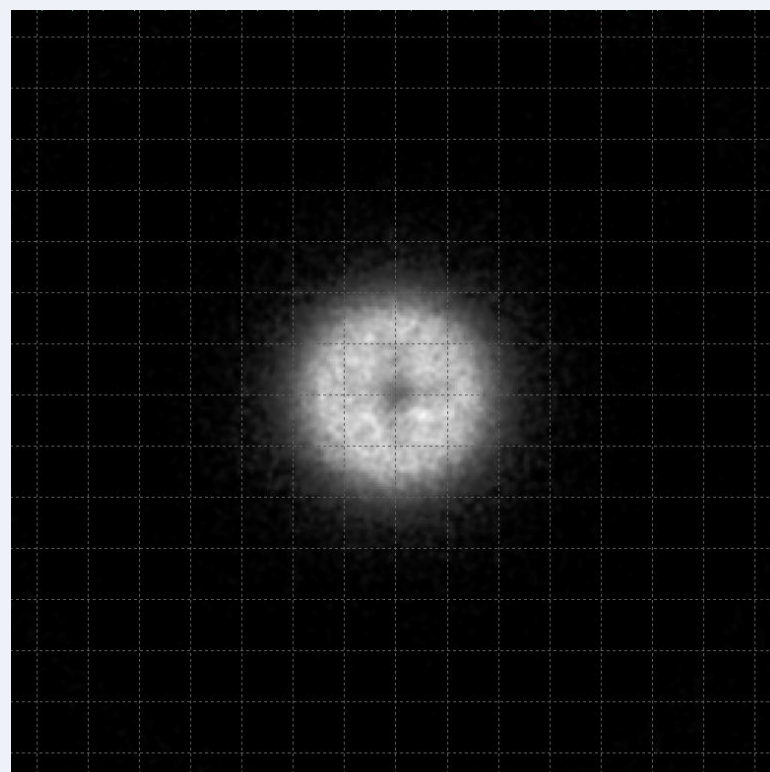

LED used for simulation	Cree XP-G
Luminous flux of LED [lm]	36
Efficiency [%]*	88
FWHM Co [°]	40
FWHM C90 [°]	40

* The ratio between luminous flux on the projection wall (3x3 m at 1 m) and luminous flux of LED

A492 C40

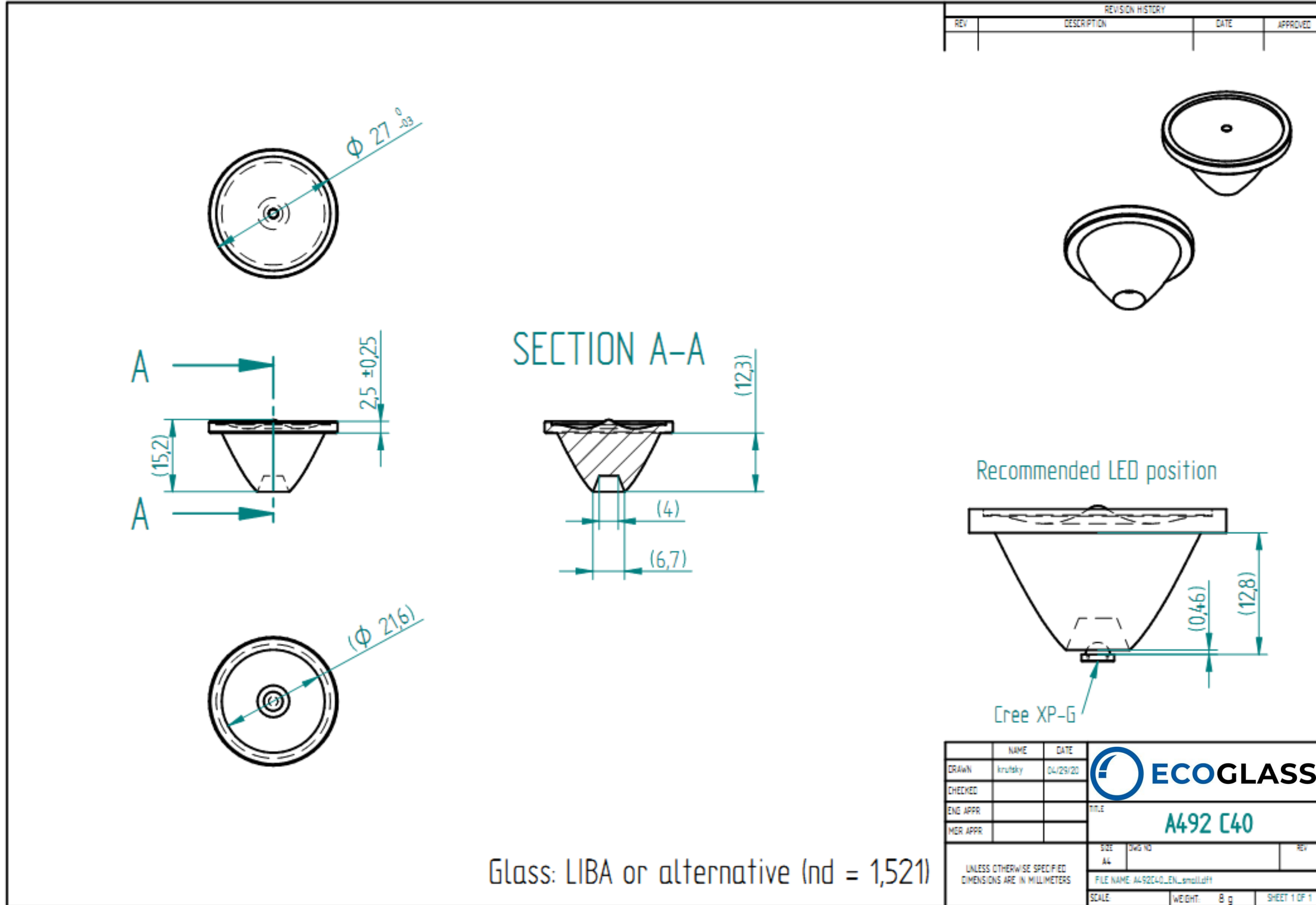

A492 C40 – simulation results

- Polar Candela Distribution Plot

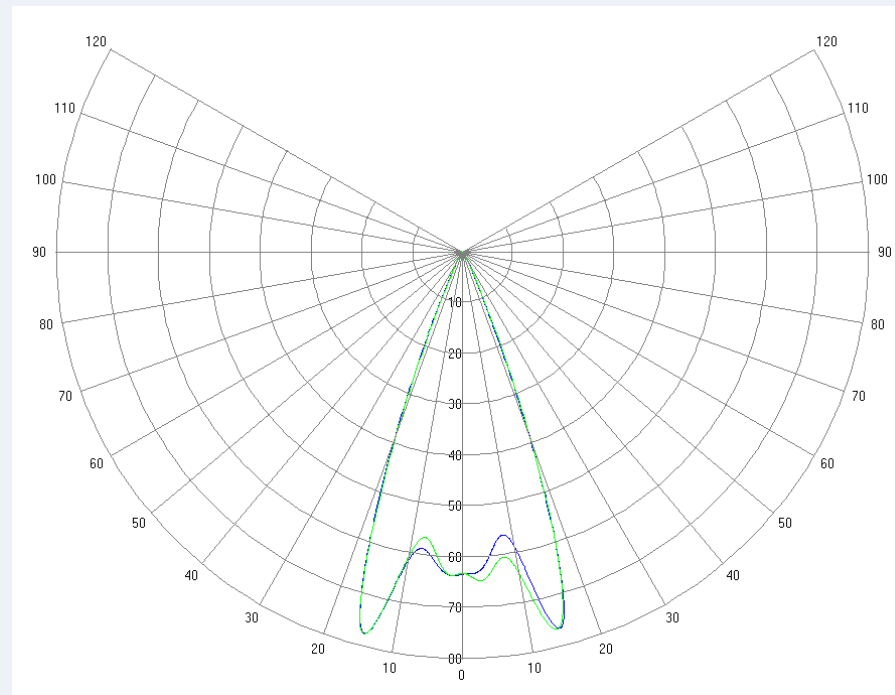

- Rectangular Candela Distribution Plot

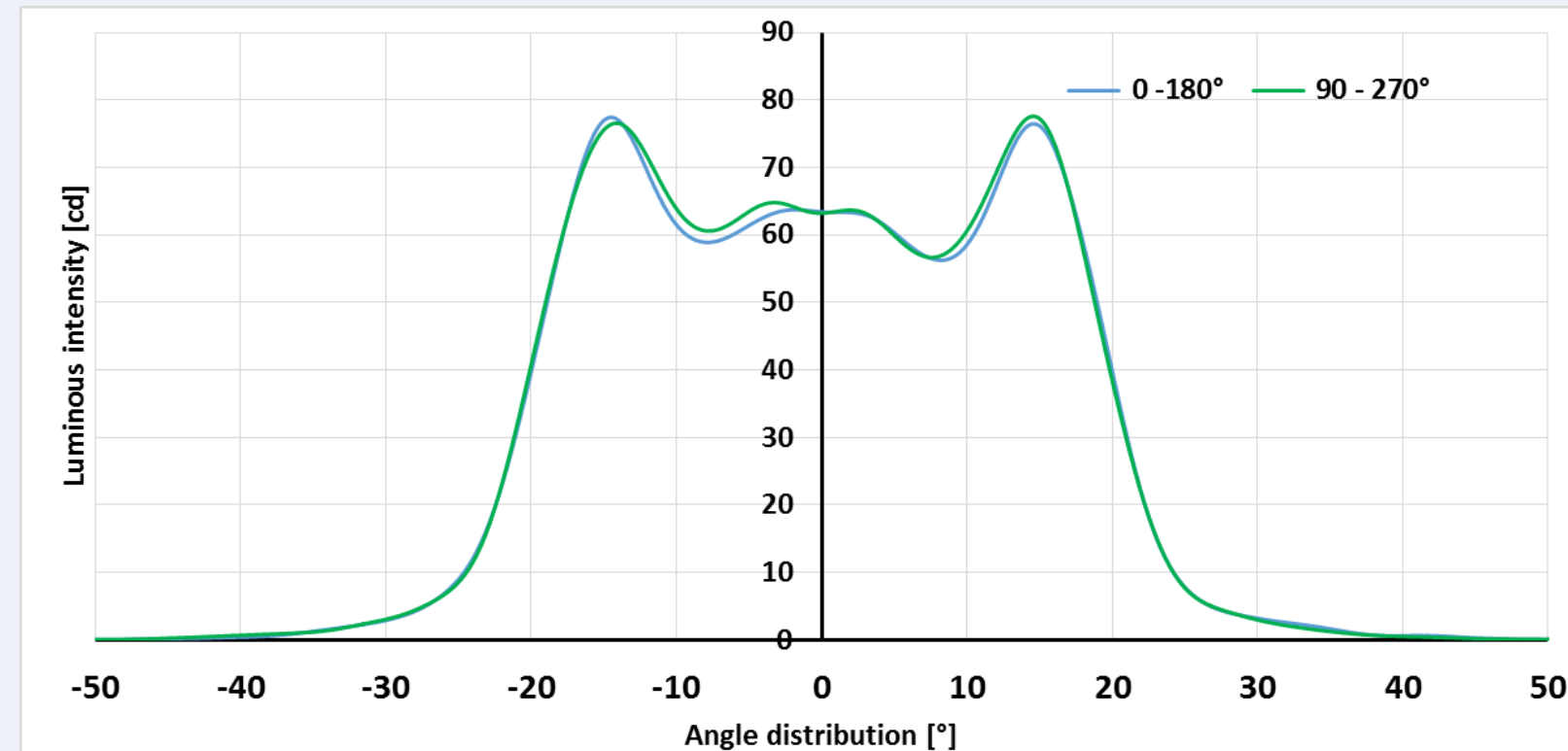

- Projection wall 3x3 m at 1m

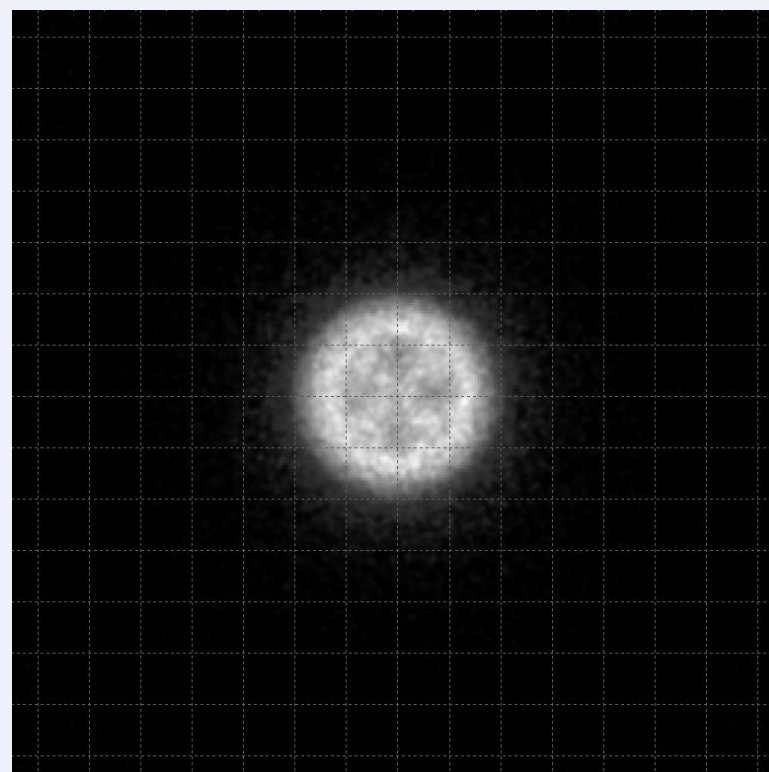

LED used for simulation	Cree XP-G
Luminous flux of LED [lm]	36
Efficiency [%]*	87
FWHM Co [°]	40
FWHM C90 [°]	40

* The ratio between luminous flux on the projection wall (3x3 m at 1 m) and luminous flux of LED

A493 C40

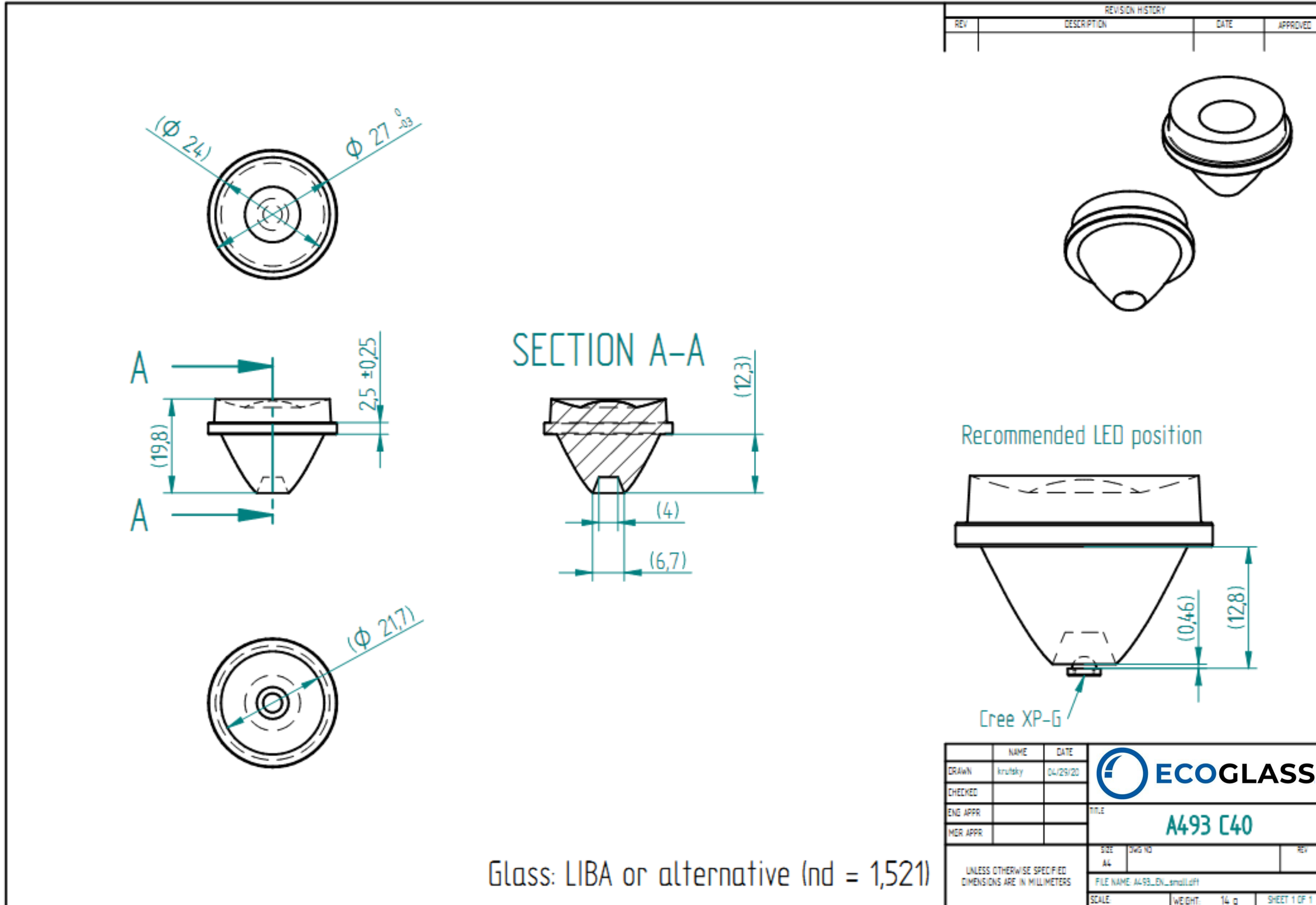

A493 C40- simulation results

- Polar Candela Distribution Plot

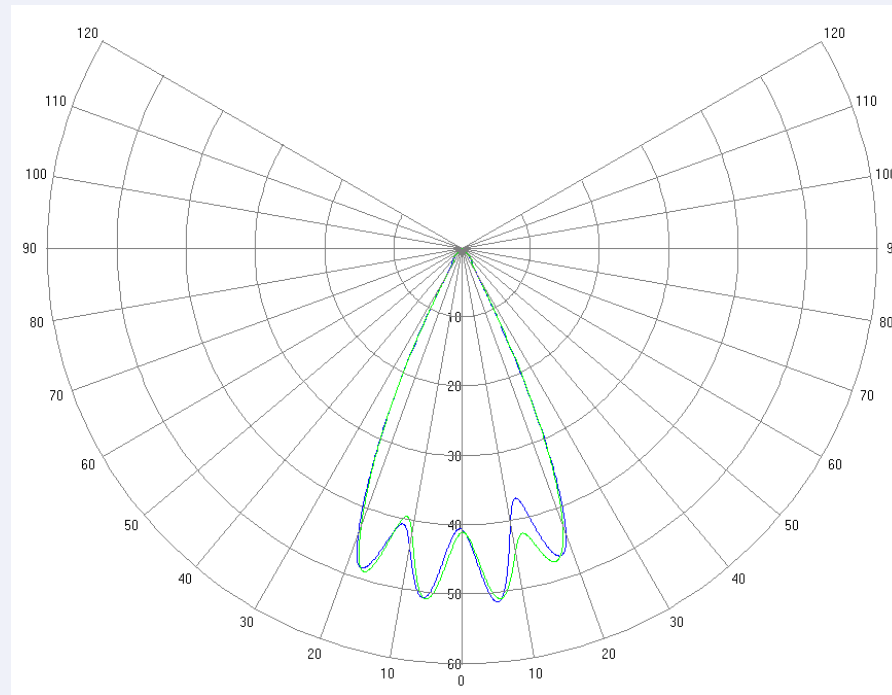

- Rectangular Candela Distribution Plot

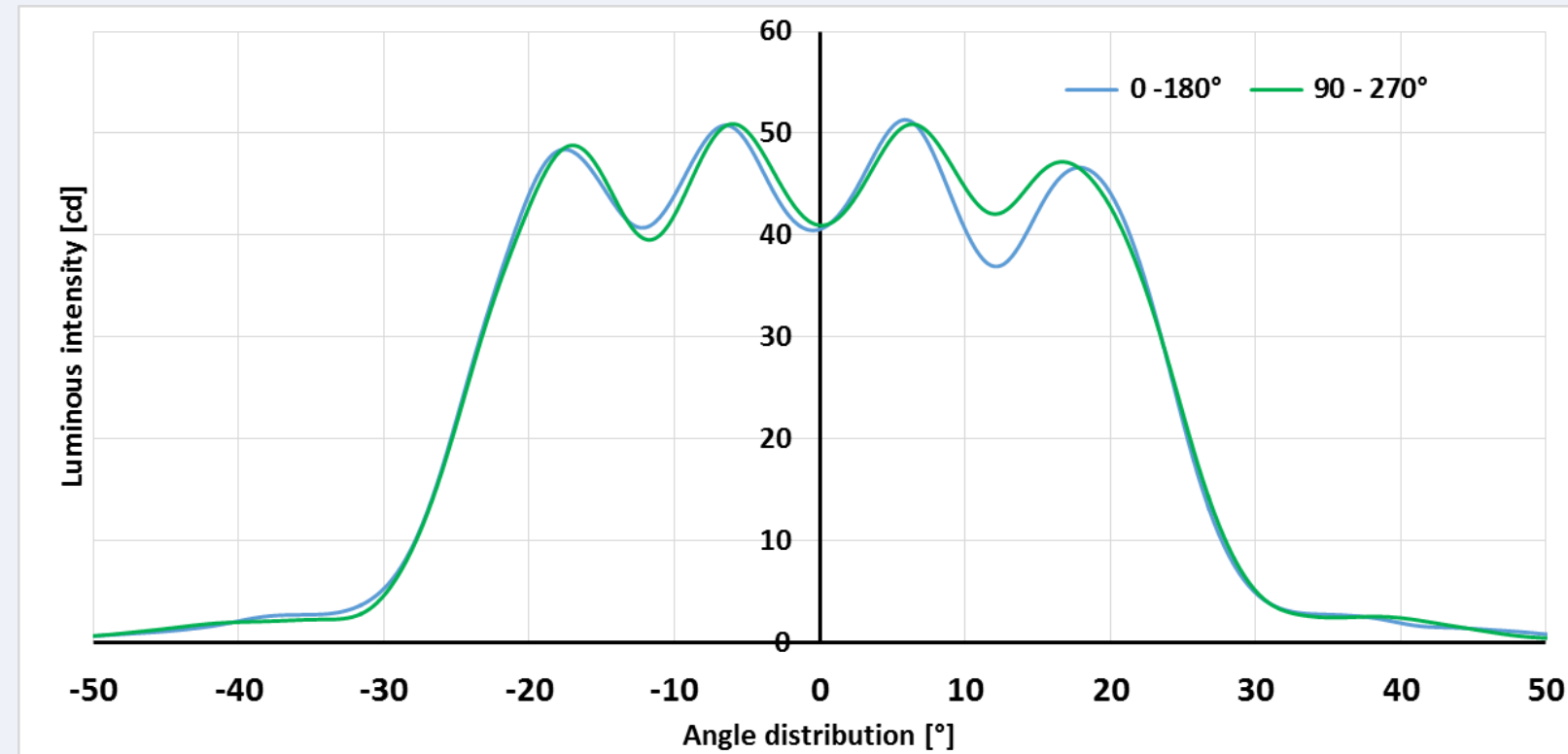

- Projection wall 3x3 m at 1m

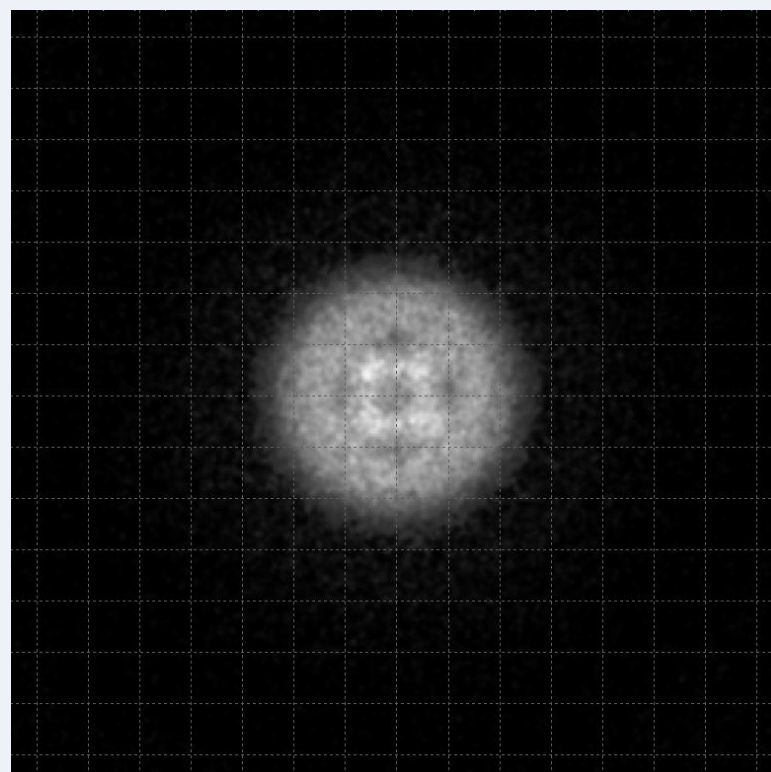

LED used for simulation	Cree XP-G
Luminous flux of LED [lm]	36
Efficiency [%]*	87
FWHM Co [°]	50
FWHM C90 [°]	50

* The ratio between luminous flux on the projection wall (3x3 m at 1 m) and luminous flux of LED

A559 5631

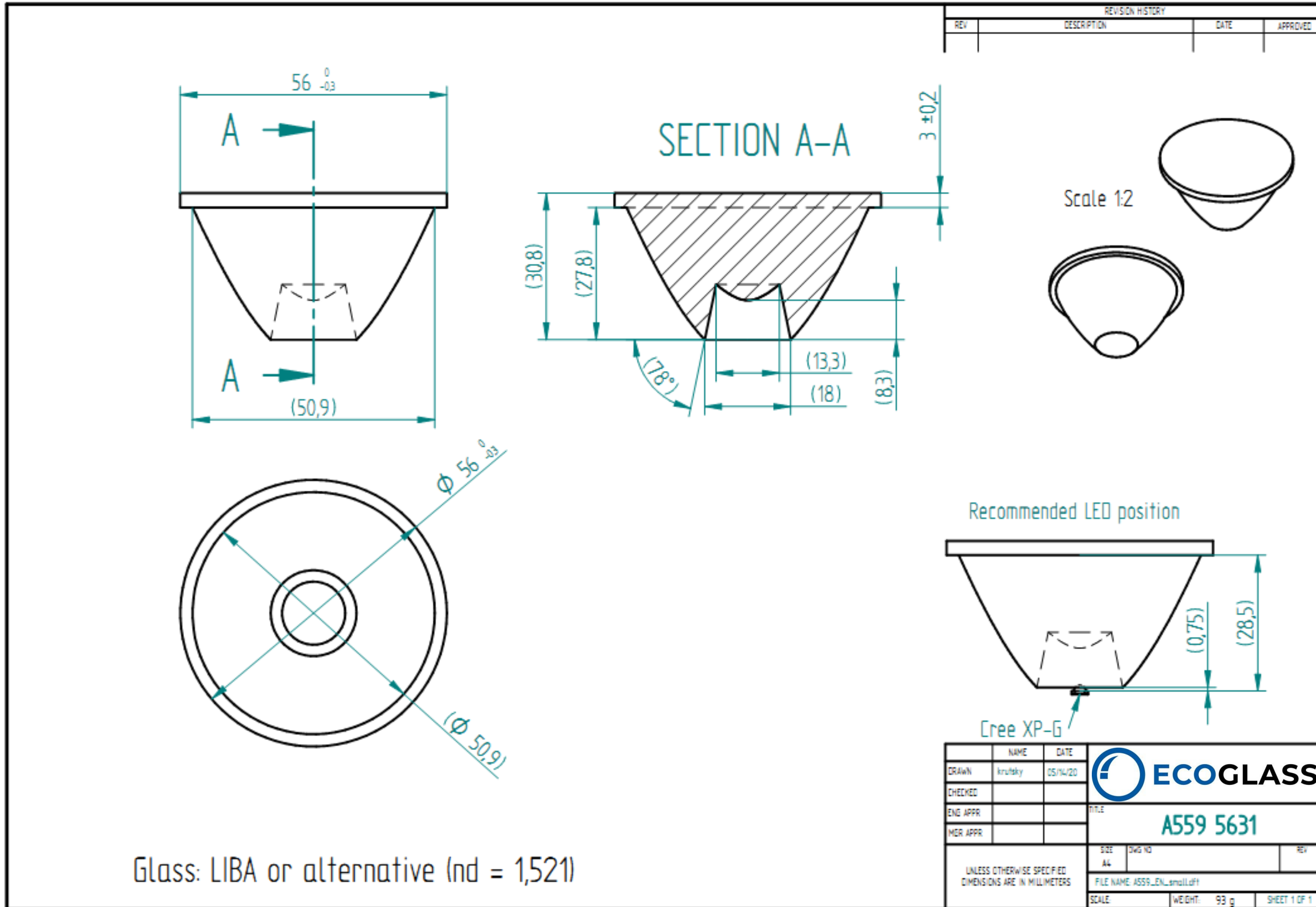

A559 5631- simulation results

- Polar Candela Distribution Plot

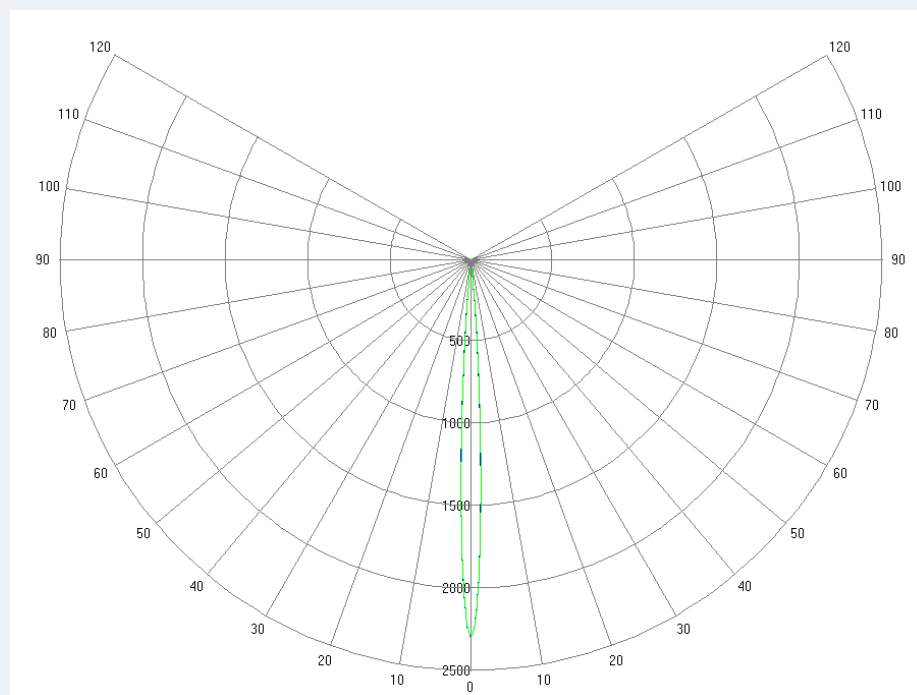

- Rectangular Candela Distribution Plot

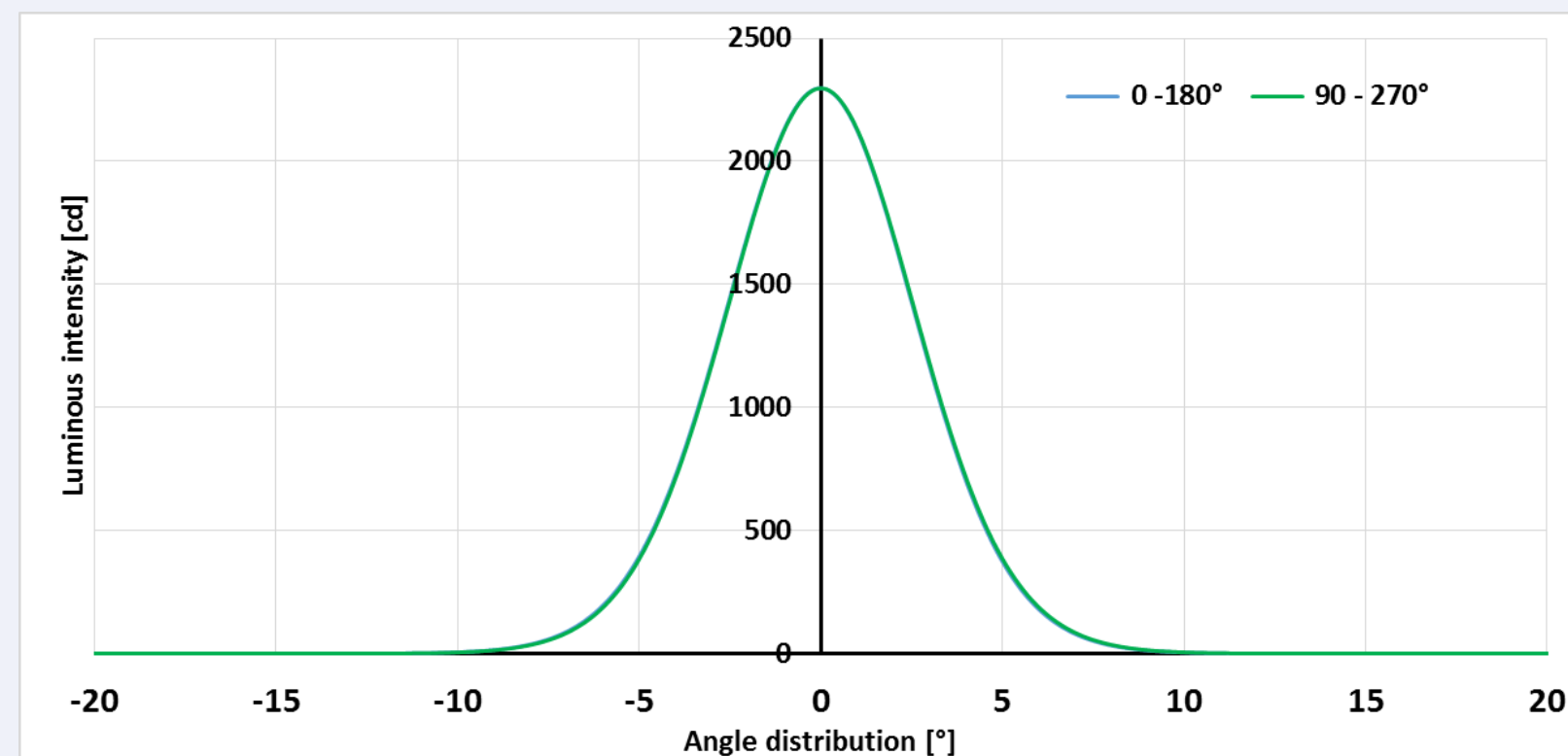

- Projection wall 3x3 m at 1m

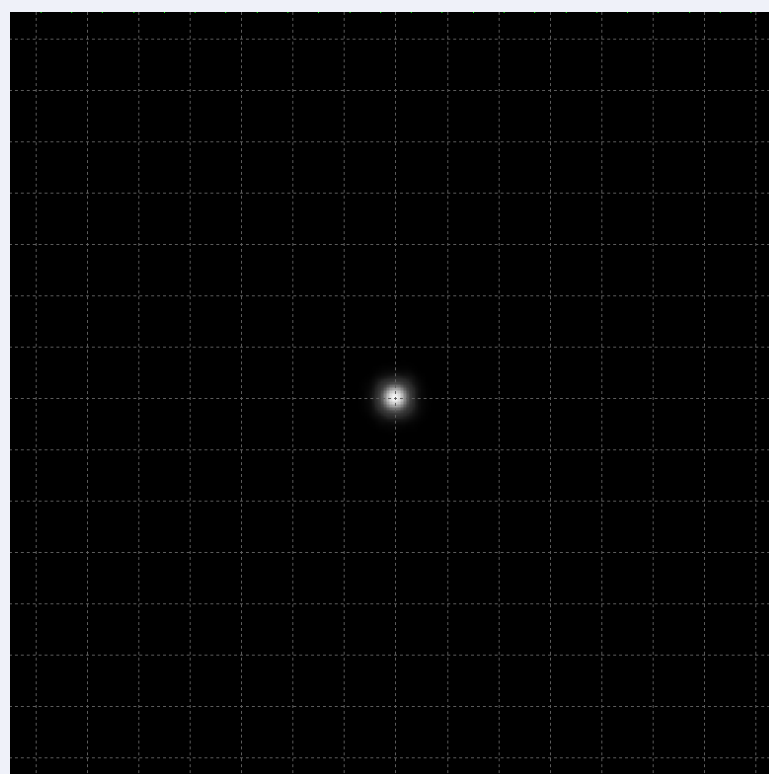

LED used for simulation	Cree XP-G
Luminous flux of LED [lm]	36
Efficiency [%]*	89
FWHM Co [°]	6,5
FWHM C90 [°]	6,5

* The ratio between luminous flux on the projection wall (3x3 m at 1 m) and luminous flux of LED

A561 7041

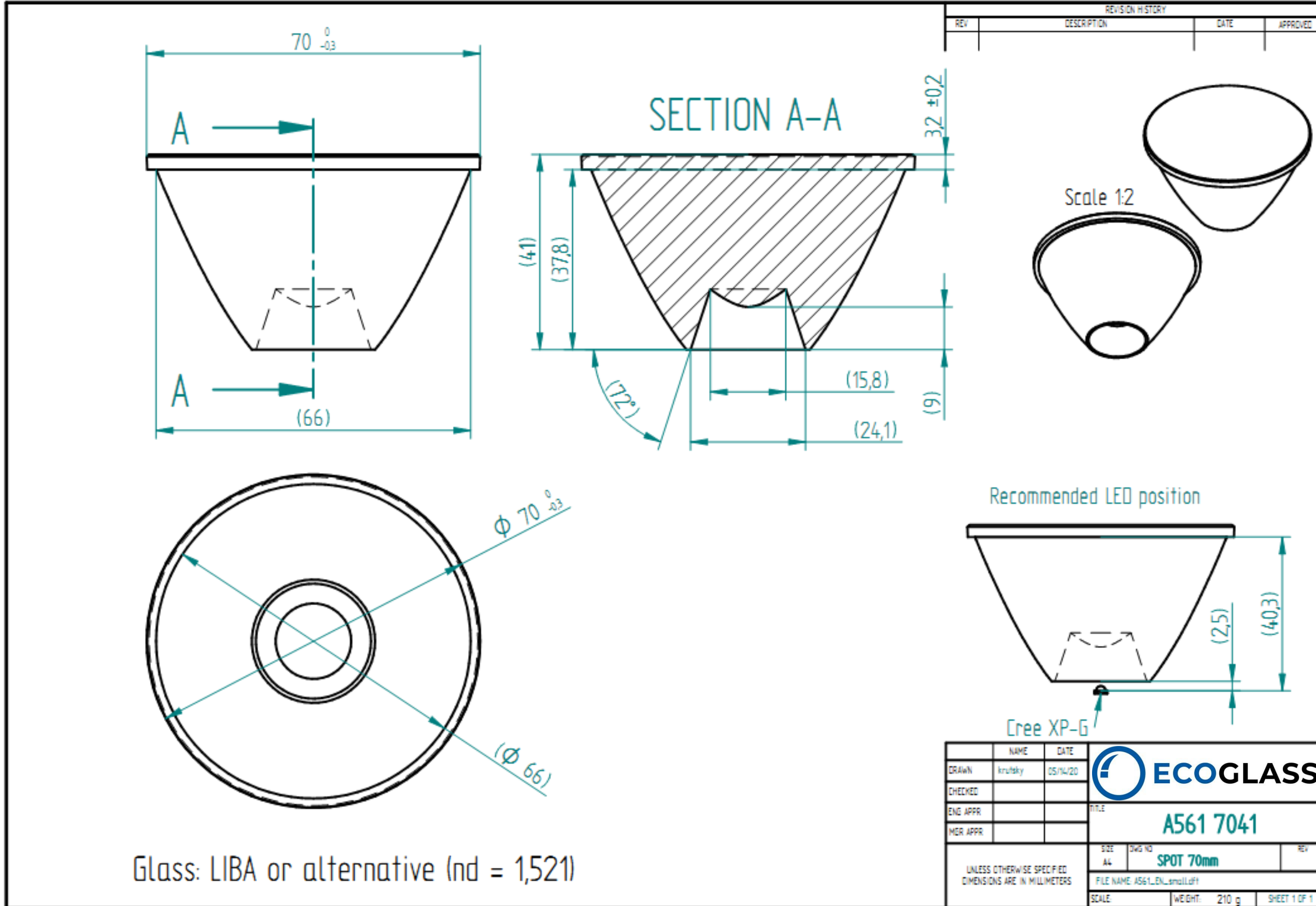

Glass: LIBA or alternative (nd = 1,521)

A561 7041- simulation results

- Polar Candela Distribution Plot

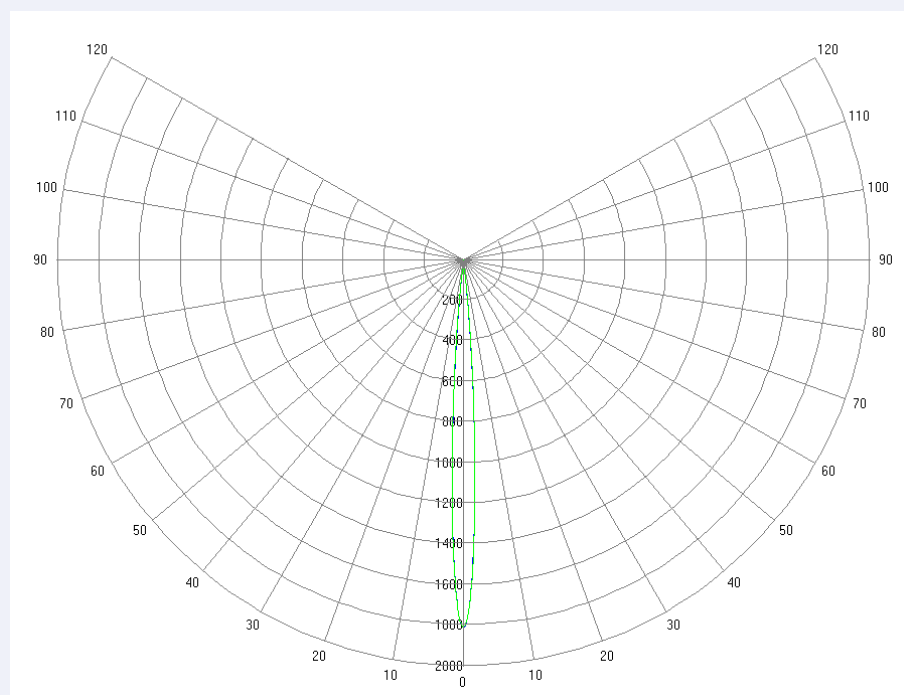

- Rectangular Candela Distribution Plot

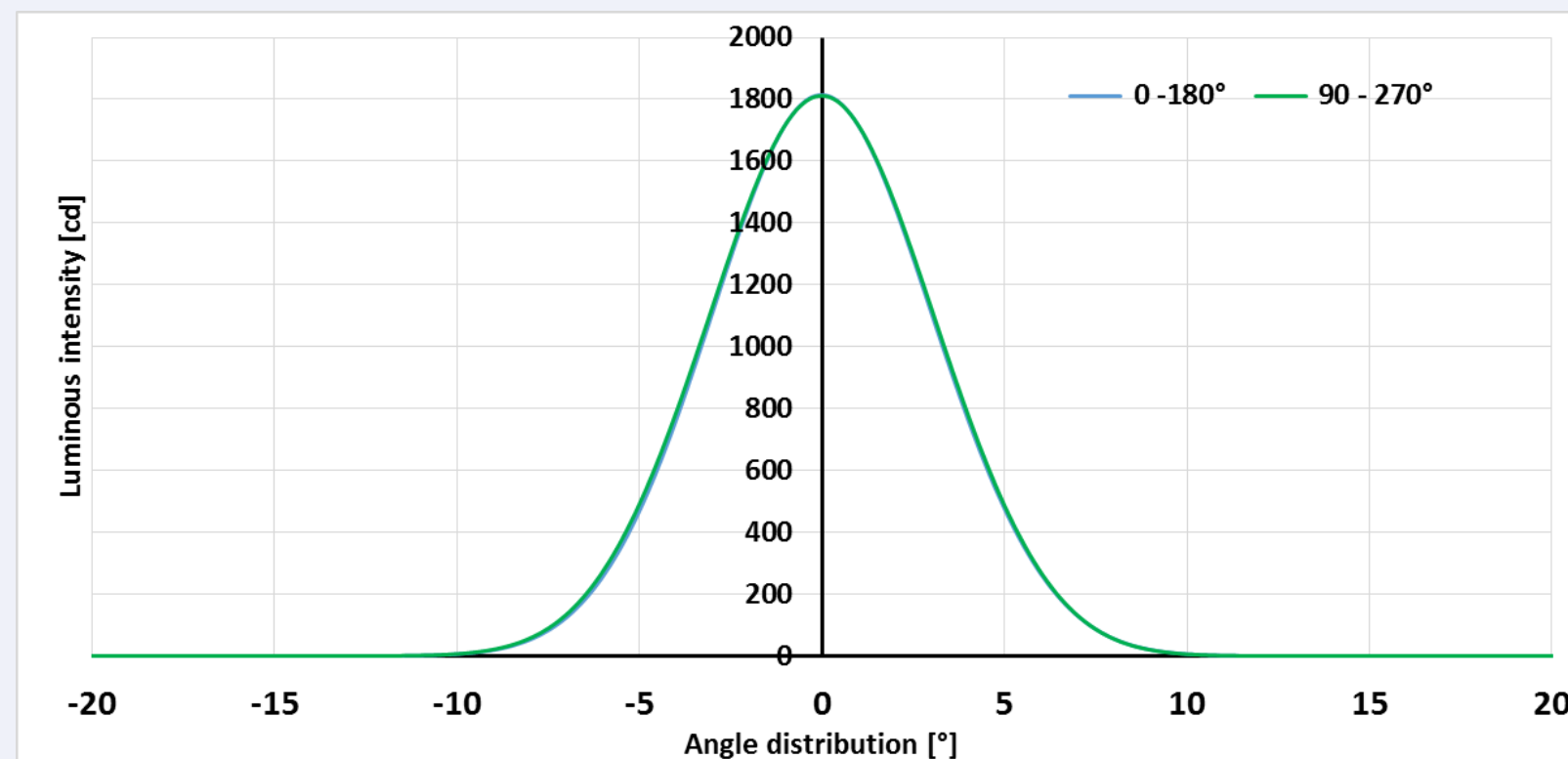

- Projection wall 3x3 m at 1m

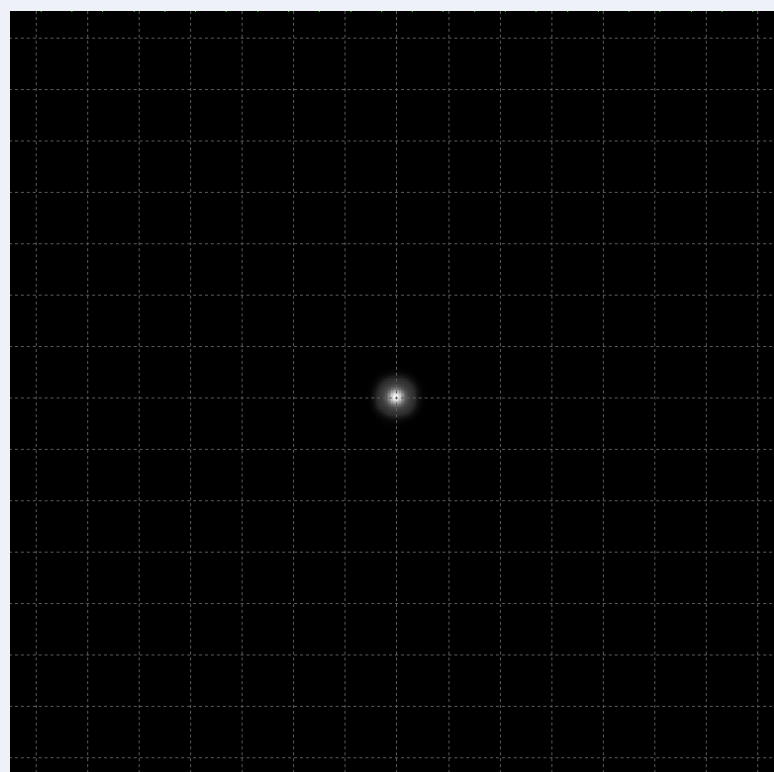

LED used for simulation	Cree XP-G
Luminous flux of LED [lm]	36
Efficiency [%]*	87
FWHM Co [°]	5,6
FWHM C90 [°]	5,6

* The ratio between luminous flux on the projection wall (3x3 m at 1 m) and luminous flux of LED

A562 3929

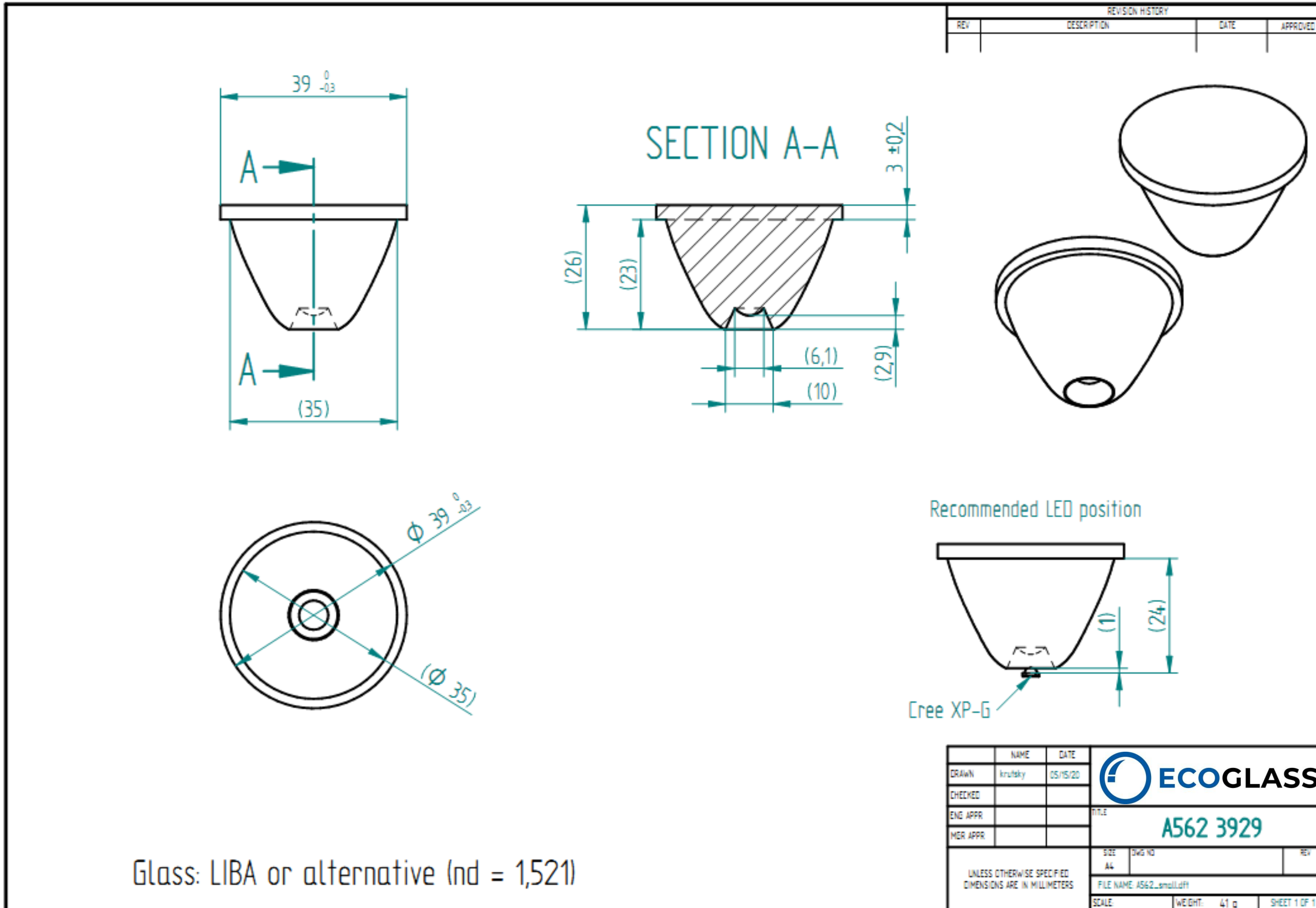

Glass: LIBA or alternative (nd = 1,521)

A562 3929 – simulation results

- Polar Candela Distribution Plot

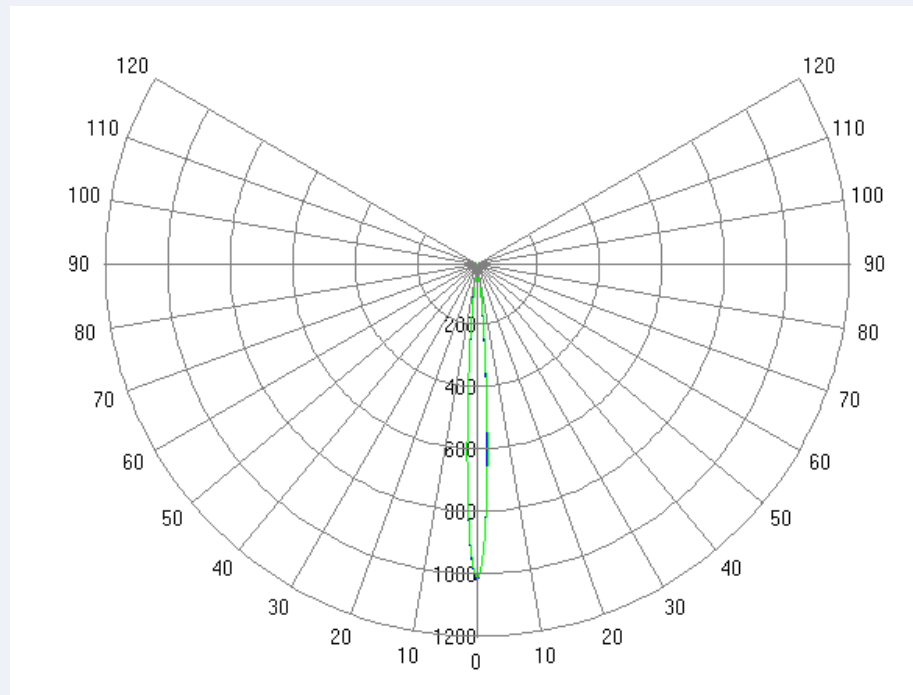

- Rectangular Candela Distribution Plot

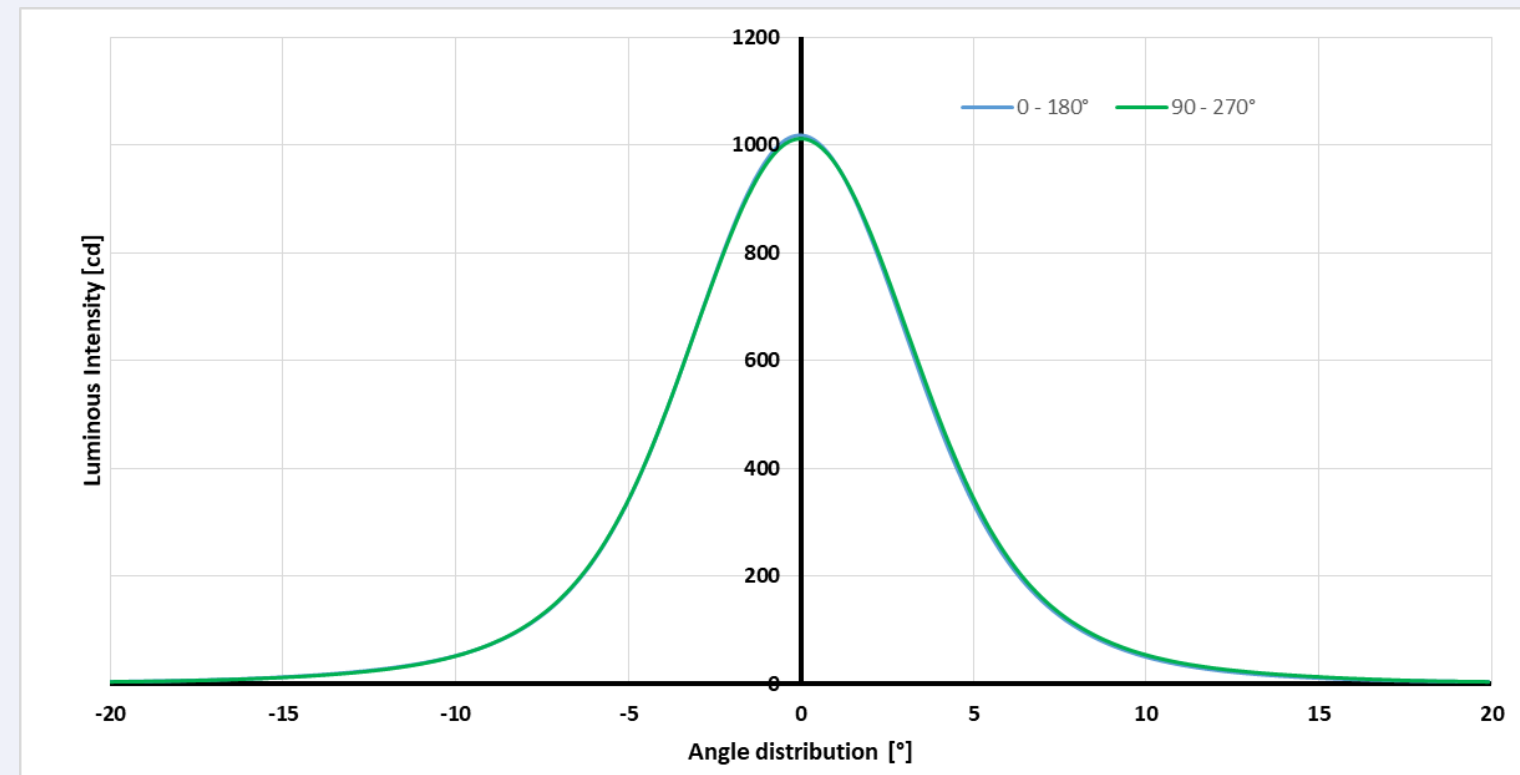

- Projection wall 3x3 m at 1m

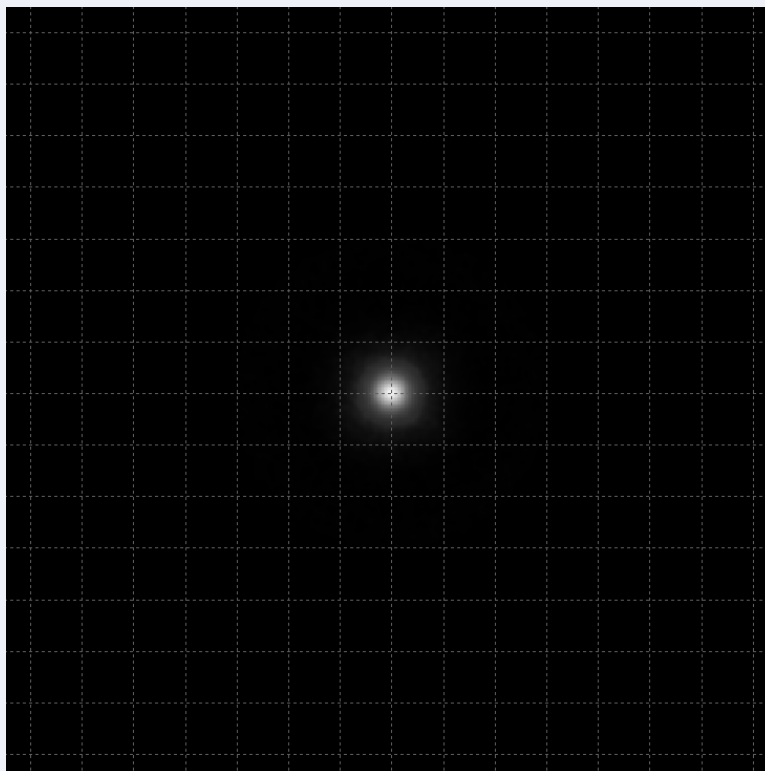

LED used for simulation	Cree XP-G
Luminous flux of LED [lm]	36
Efficiency [%]*	88
FWHM Co [°]	7,8
FWHM C90 [°]	7,8

* The ratio between luminous flux on the projection wall (3x3 m at 1 m) and luminous flux of LED

A643 C20

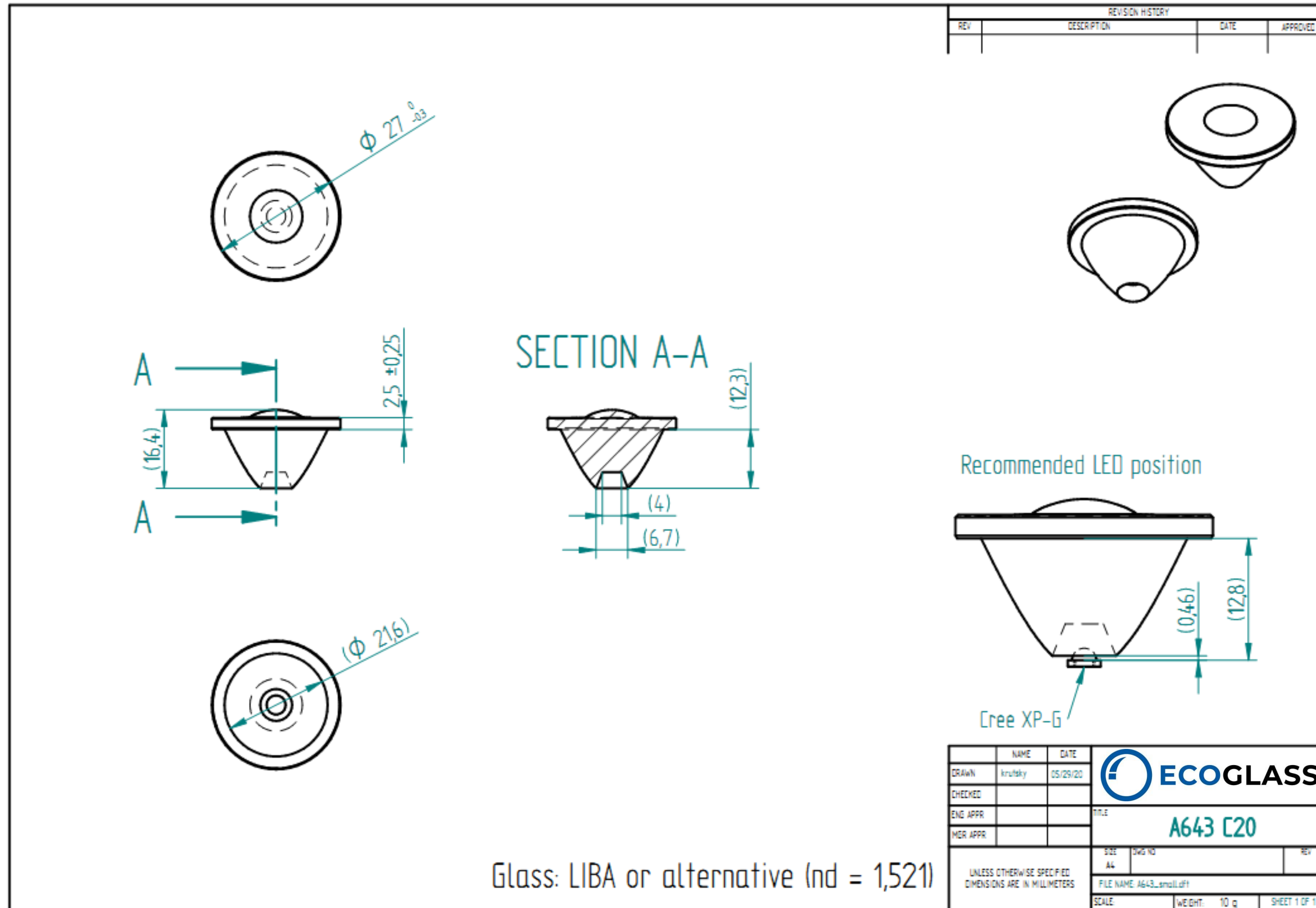

A643 C20- simulation results

- Polar Candela Distribution Plot

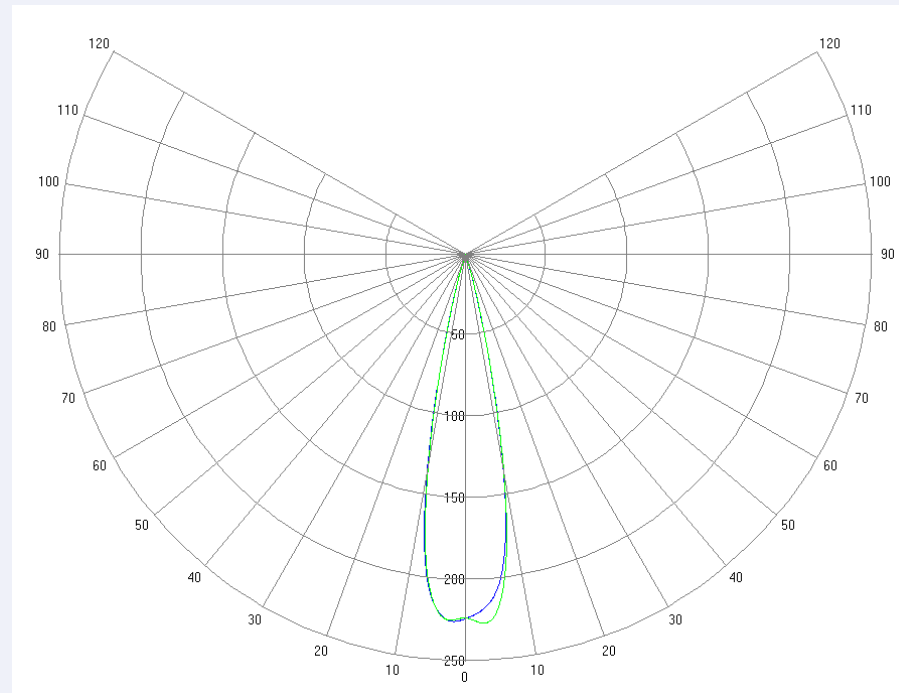

- Rectangular Candela Distribution Plot

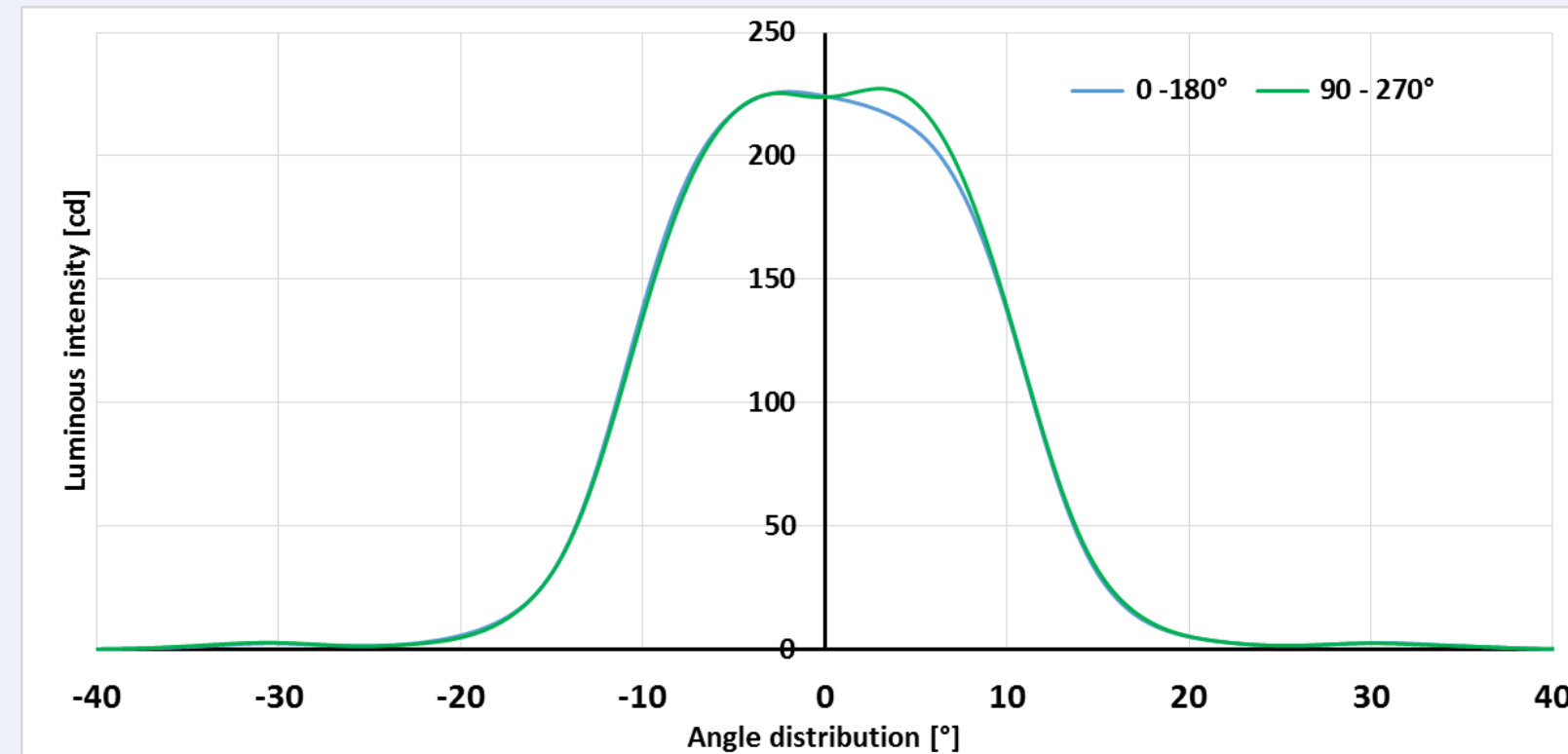

- Projection wall 3x3 m at 1m

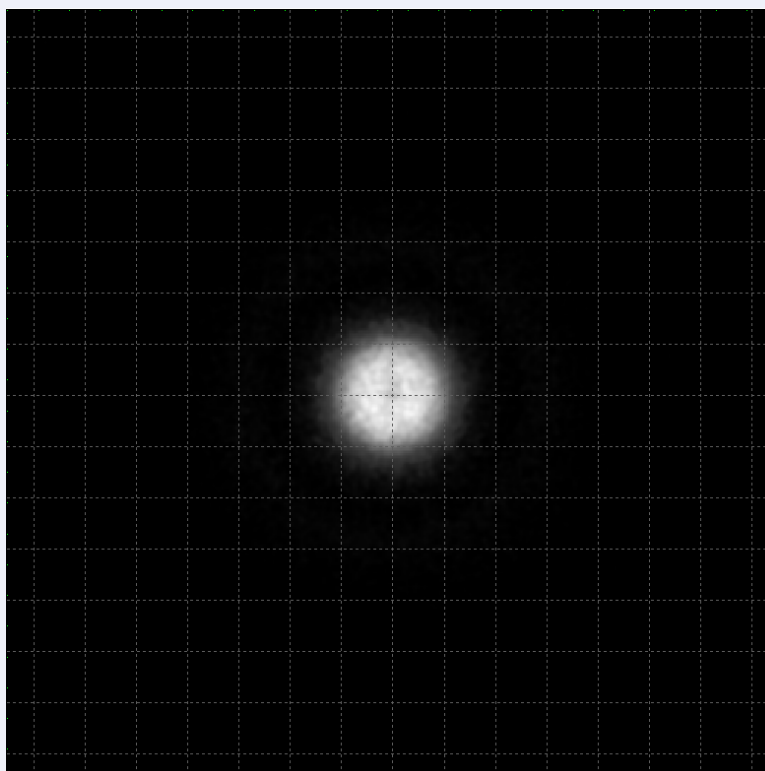

LED used for simulation	Cree XP-G
Luminous flux of LED [lm]	36
Efficiency [%]*	87
FWHM Co [°]	20
FWHM C90 [°]	20

* The ratio between luminous flux on the projection wall (3x3 m at 1 m) and luminous flux of LED

ECOGLOSS Cavity Lenses

ECOGLOSS code	Lens type	Beam angles FWHM (°) *		Diameter (mm)	Thickness (mm)
		Co (0°)	C90 (90°)		
A494 C120	Cavity lens	120	120	34,0	13,5
A508 4018	Cavity lens	110	110	40,0	13,5
A569 7624	Cavity lens	20	120	76,0	24,0
A886 6629	Cavity lens	60	60	66	28,7
A892 6624	Cavity lens	90	90	66	25,9
A893 6624	Cavity lens	120	120	66	21,4
A958 7625	Cavity lens	140	50	76	25

* FWHM = full width at half maximum



A494 C120

REVISION HISTORY			
REV	DESCRIPTION	DATE	APPROVED

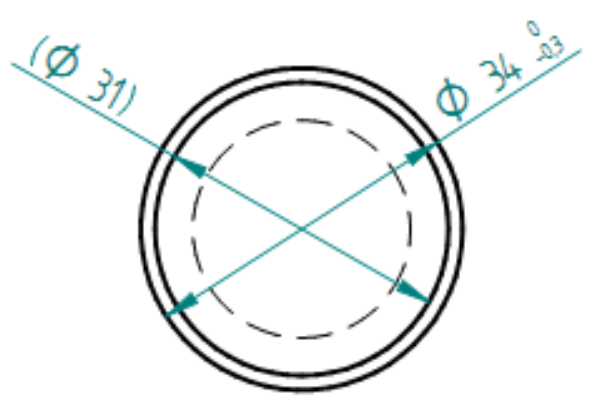
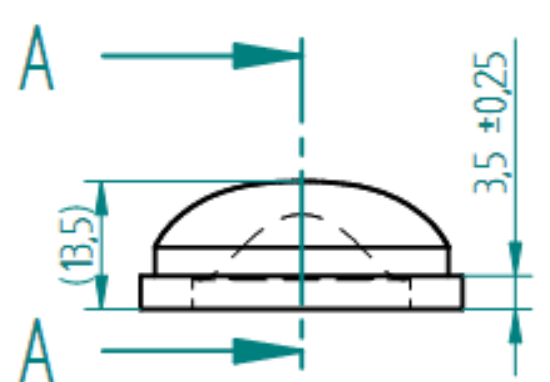
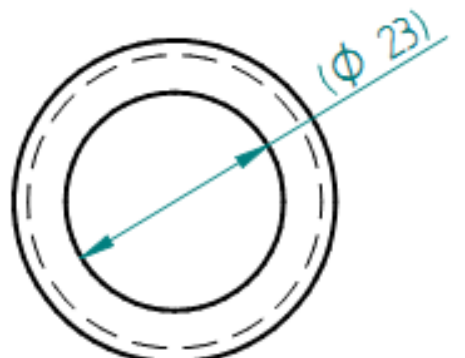



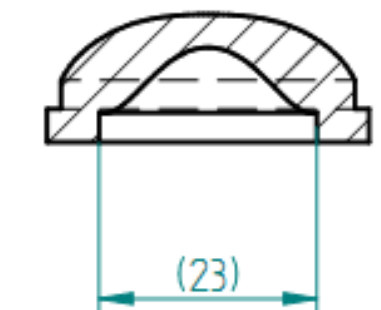

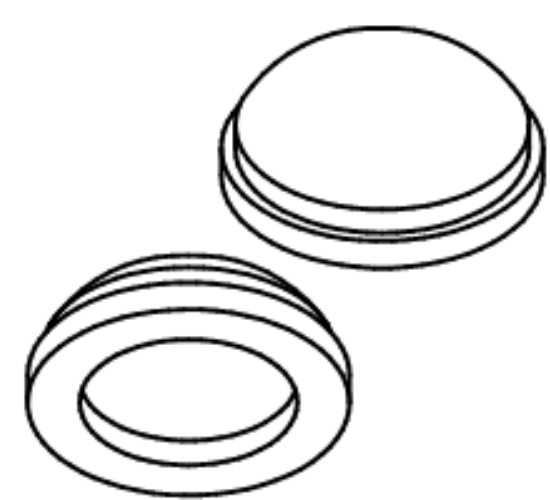
SECTION A-A



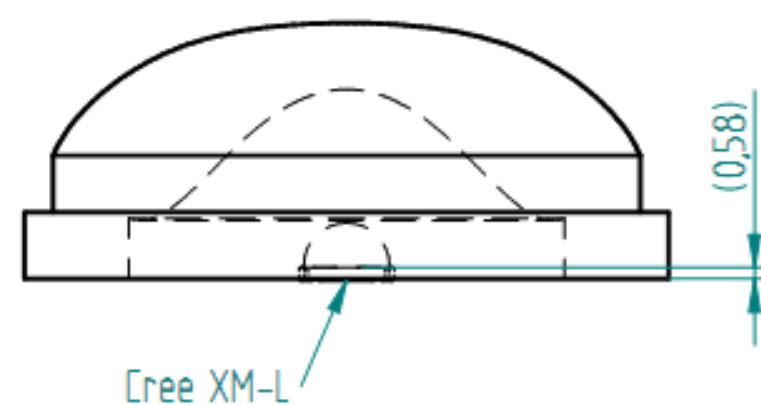

Recommended LED position



DRAWN	krutsky	DATE	04/29/20	
CHECKED				
ENG APPR				
MGR APPR				
A494 C120				TITLE
UNLESS OTHERWISE SPECIFIED, DIMENSIONS ARE IN MILLIMETERS				FILE NAME: A4-94C120_EN_small.dxf
SCALE		WEIGHT: 17 g		SHEET 1 OF 1

Glass: LIBA or alternative (nd = 1,521)

A494 C120 – simulation results

- Polar Candela Distribution Plot

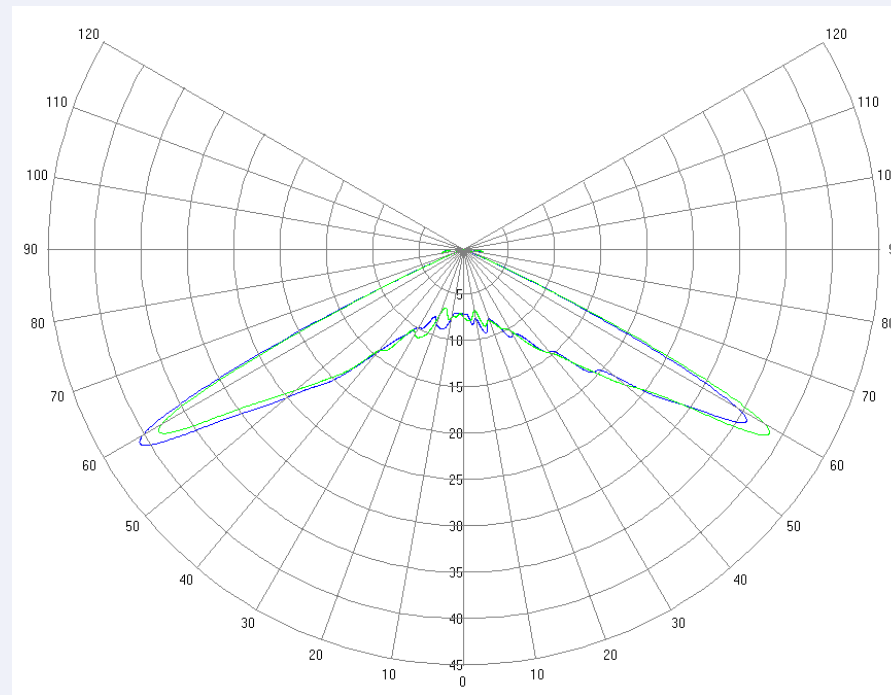

- Rectangular Candela Distribution Plot

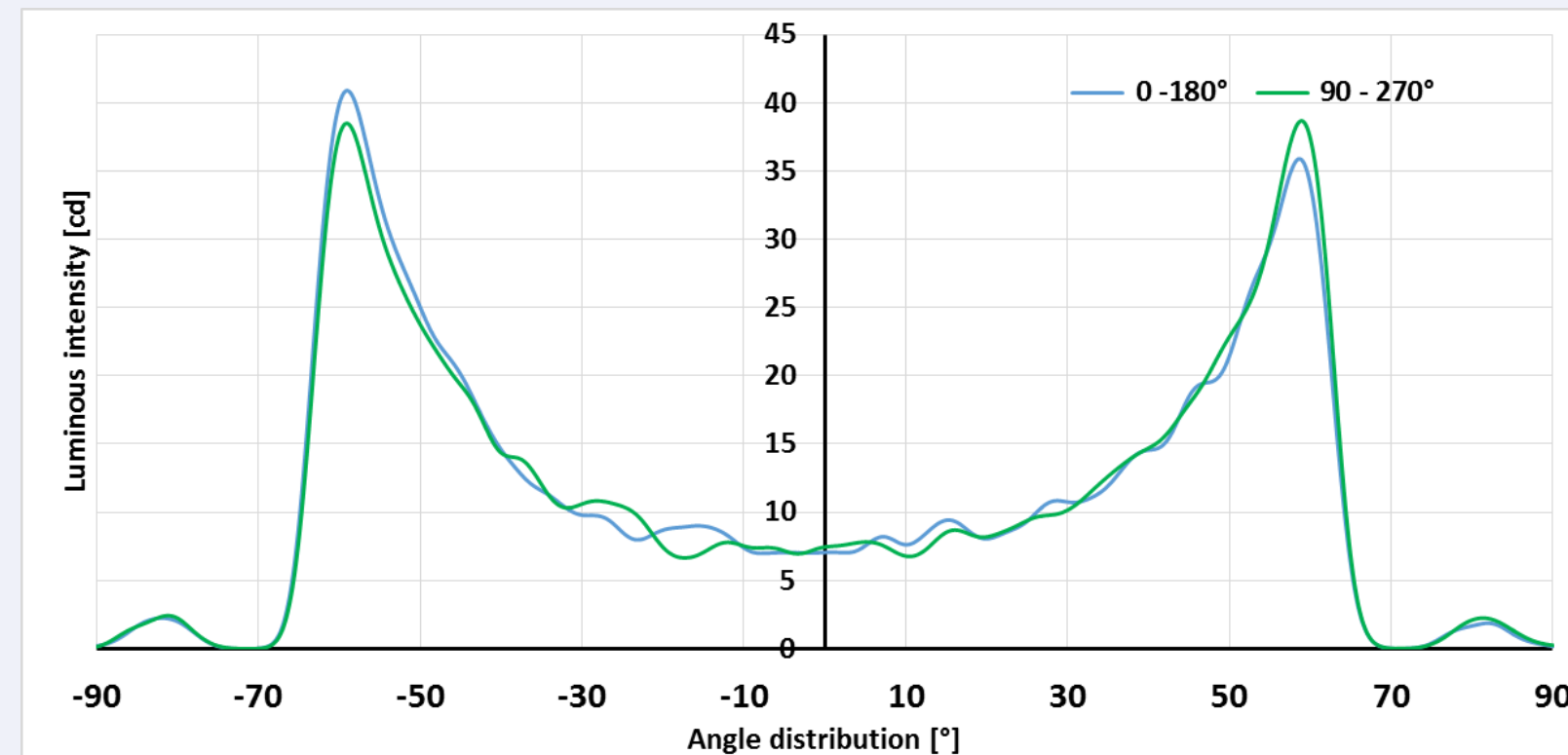

- Projection wall 5x5 m at 1m

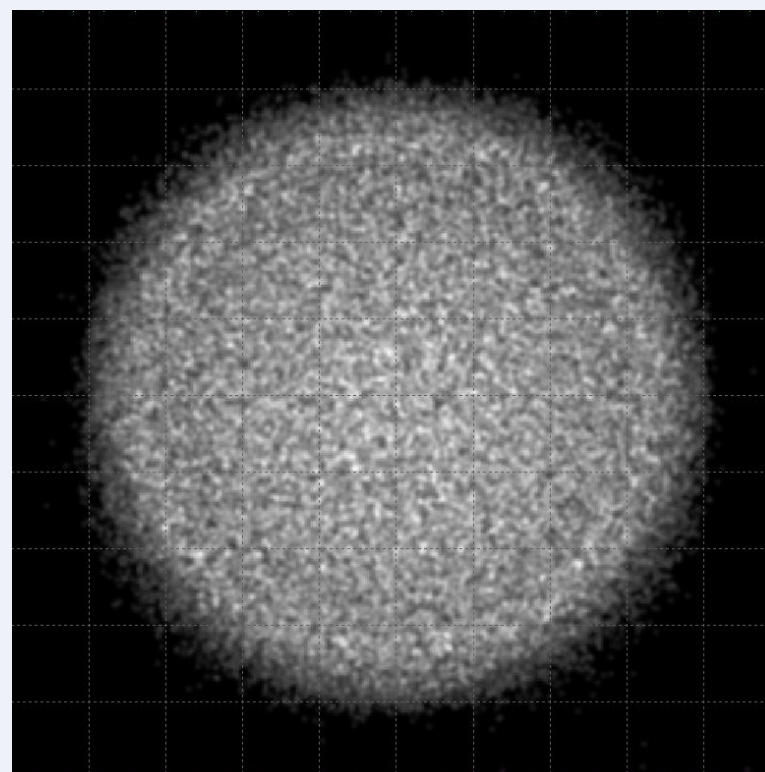

LED used for simulation	Cree XP-G
Luminous flux of LED [lm]	79
Efficiency [%]*	89
FWHM Co [°]	120
FWHM C90 [°]	120

* The ratio between luminous flux on the projection wall (5x5 m at 1 m) and luminous flux of LED

A508 4018

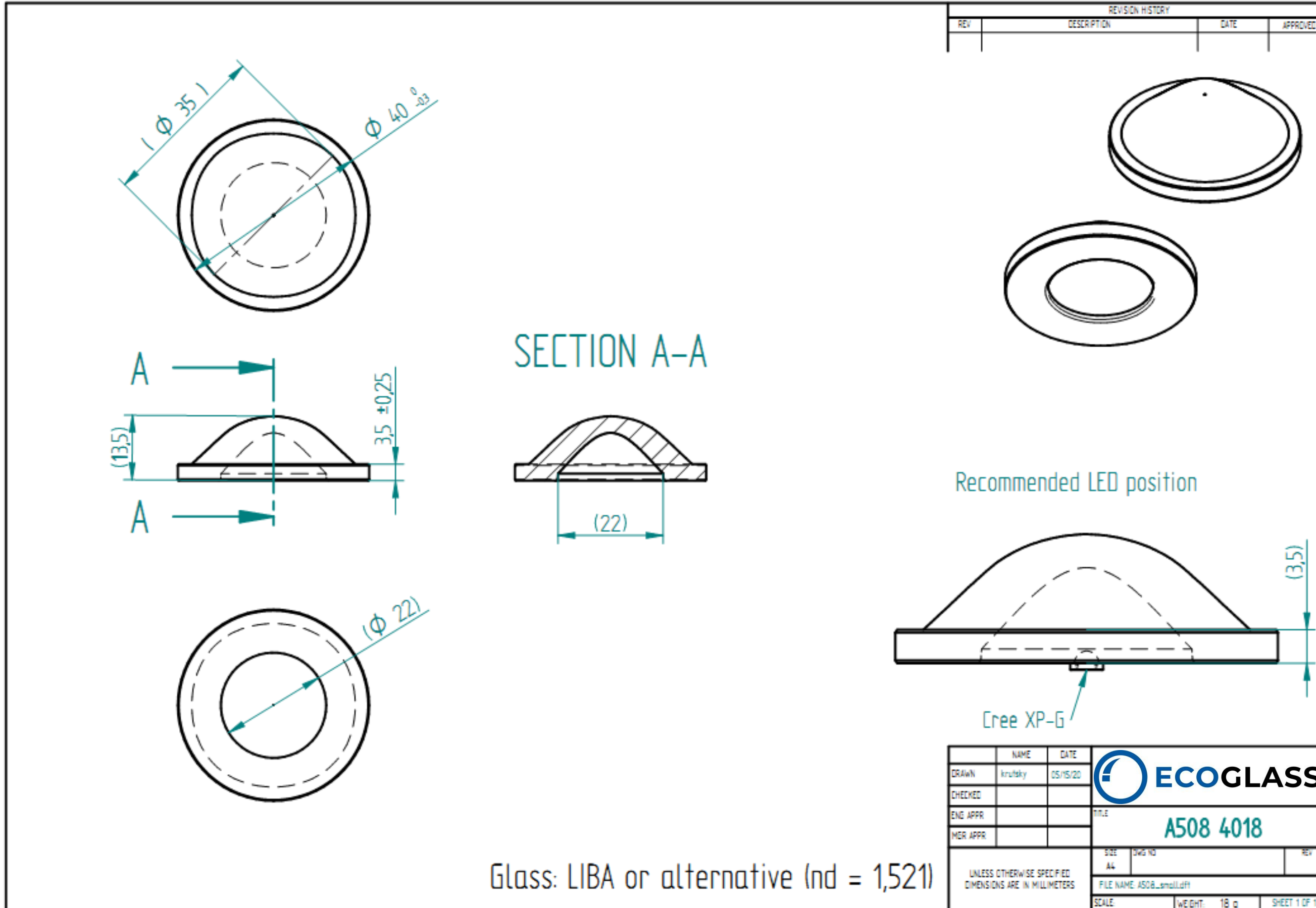

Glass: LIBA or alternative (nd = 1,521)

A508 4018 – simulation results

- Polar Candela Distribution Plot

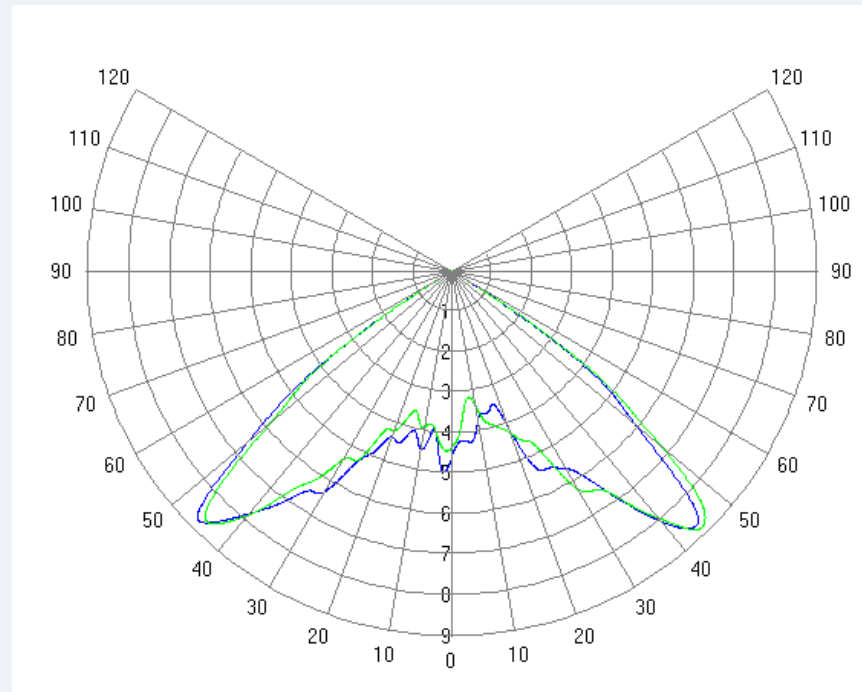

- Rectangular Candela Distribution Plot

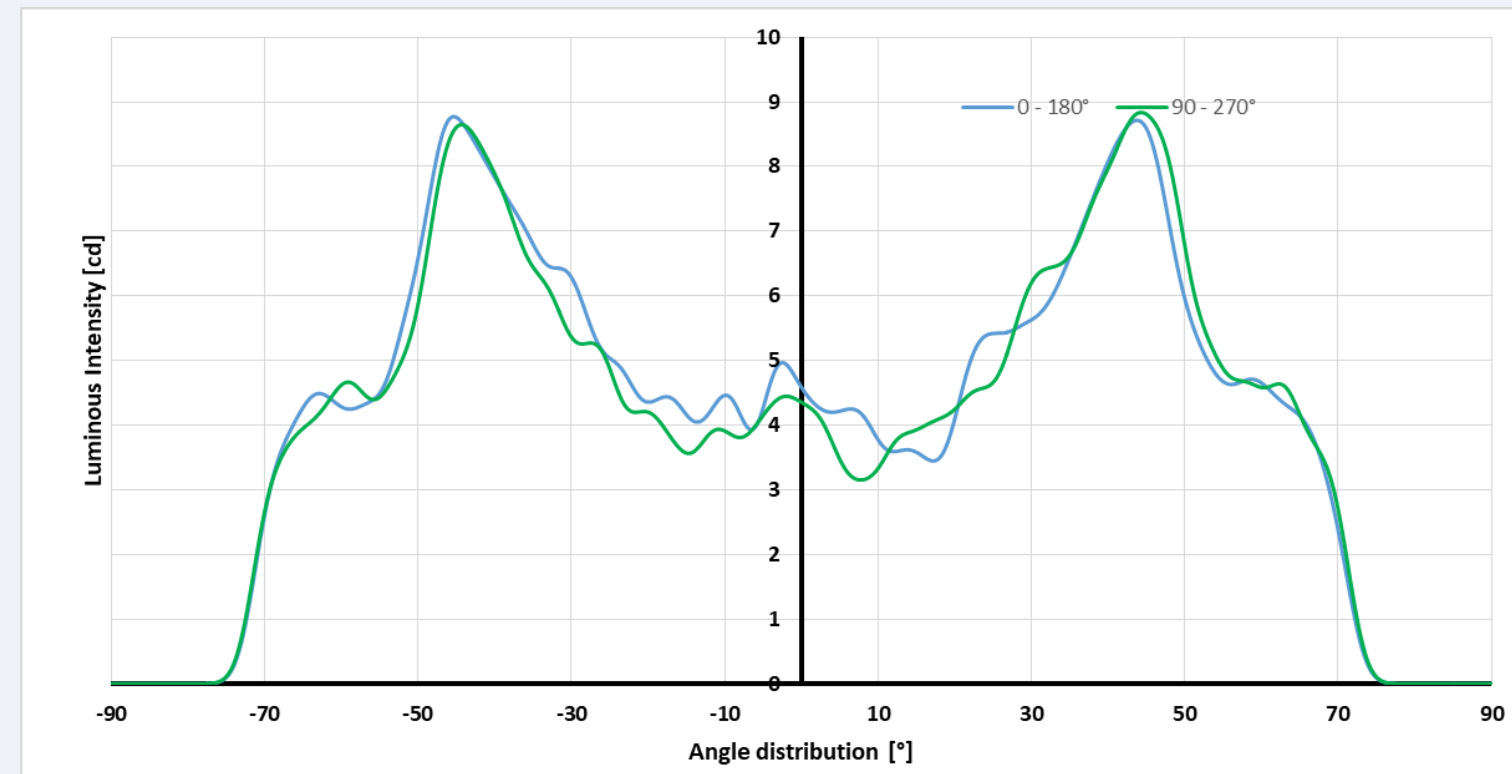

- Projection wall 5x5 m at 1m

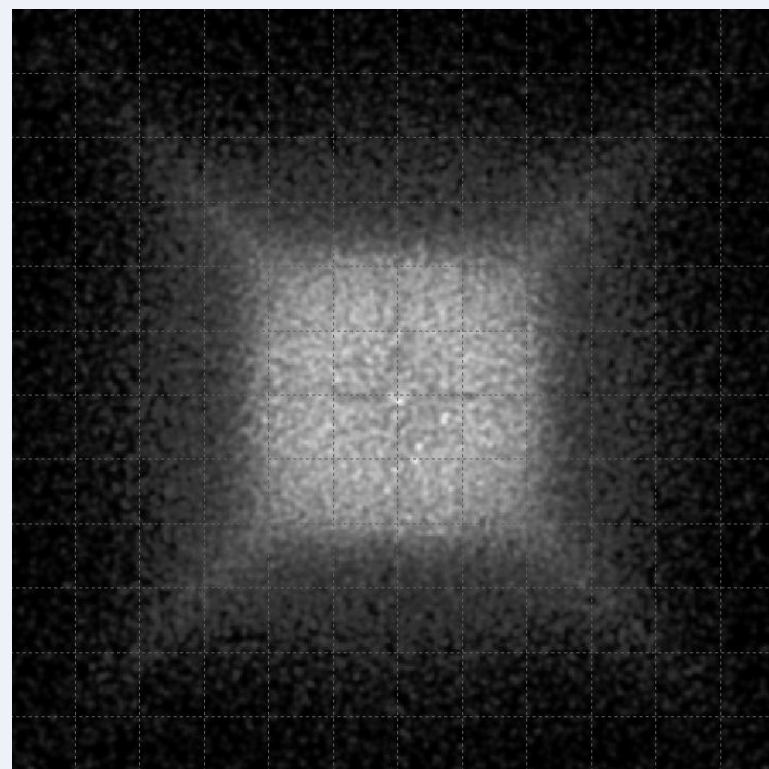

LED used for simulation	Cree XP-G
Luminous flux of LED [lm]	36
Efficiency [%]*	62
FWHM C ₀ [°]	110
FWHM C ₉₀ [°]	110

* The ratio between luminous flux on the projection wall (5x5 m at 1 m) and luminous flux of LED

A569 7624

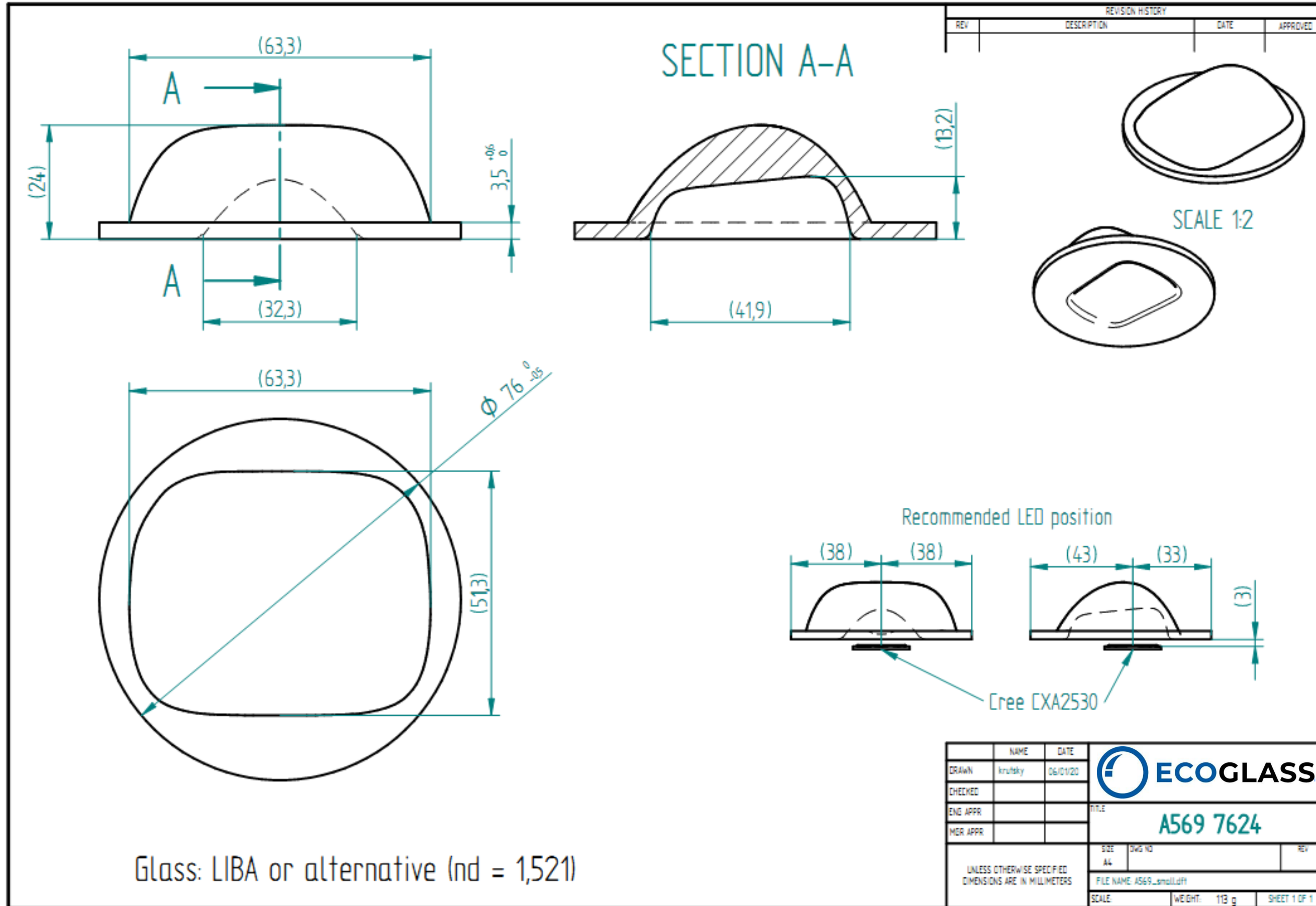

A569 7624- simulation results

- Polar Candela Distribution Plot

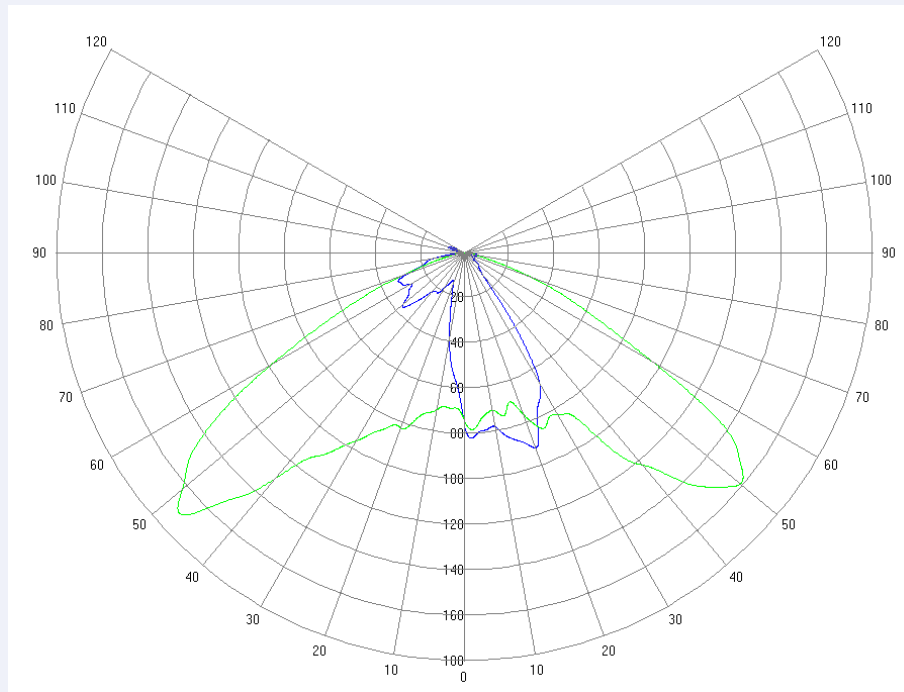

- Rectangular Candela Distribution Plot

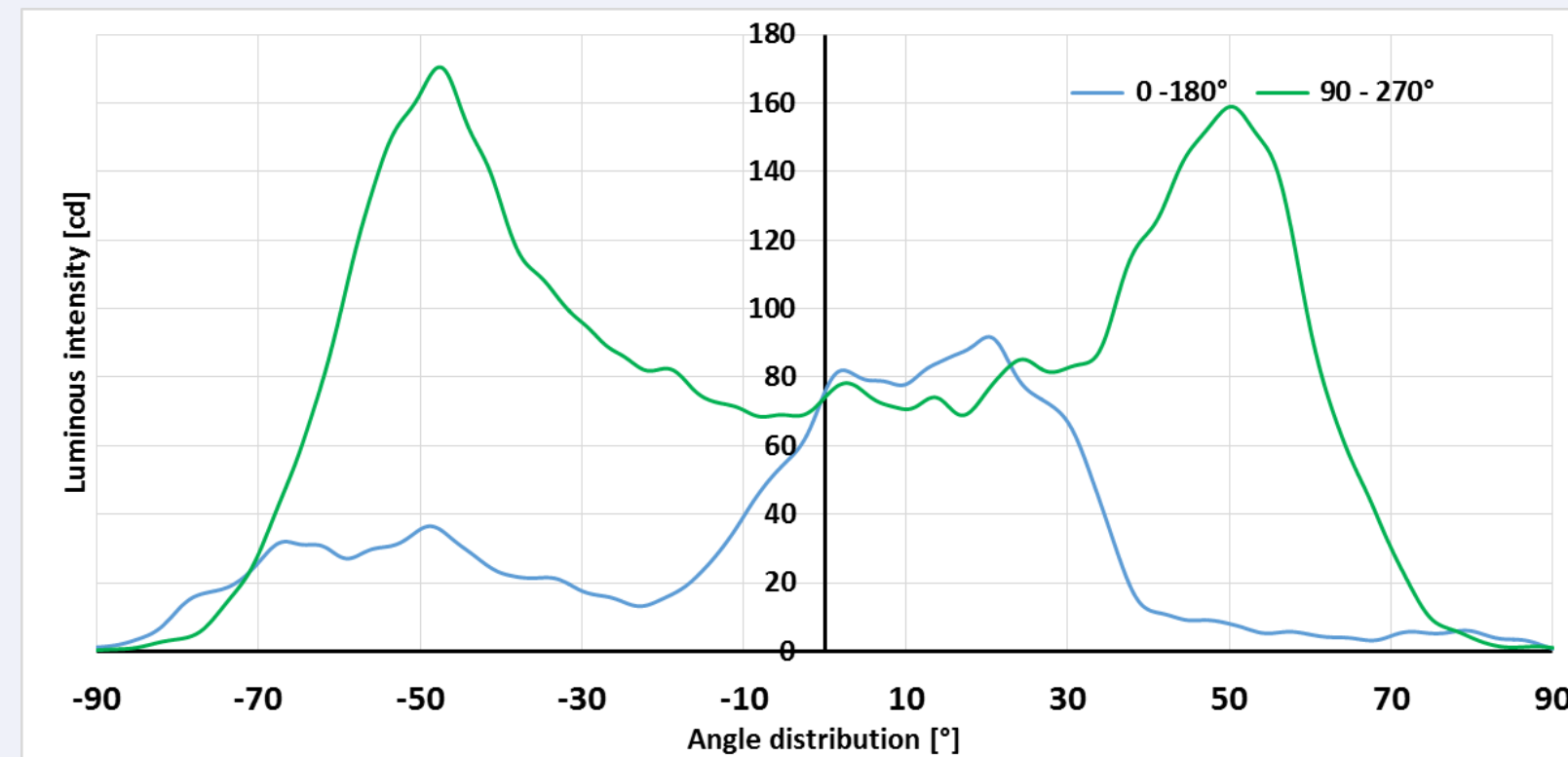

- Projection wall 5x5 m at 1m

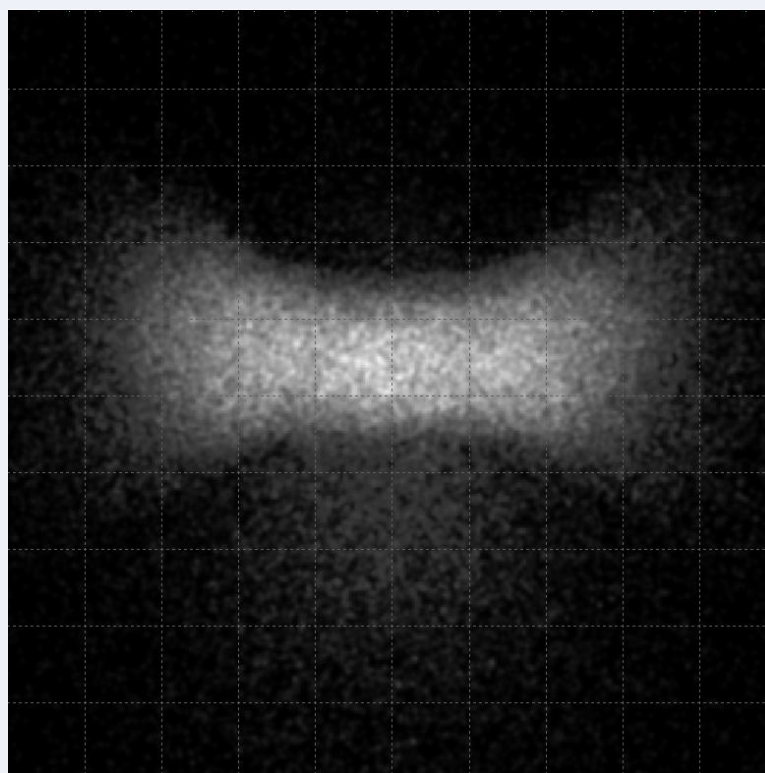

LED used for simulation	Cree CXA 2530
Luminous flux of LED [lm]	267
Efficiency [%]*	84
FWHM Co [°]	20
FWHM C90 [°]	120

* The ratio between luminous flux on the projection wall (5x5 m at 1 m) and luminous flux of LED

A886 6629

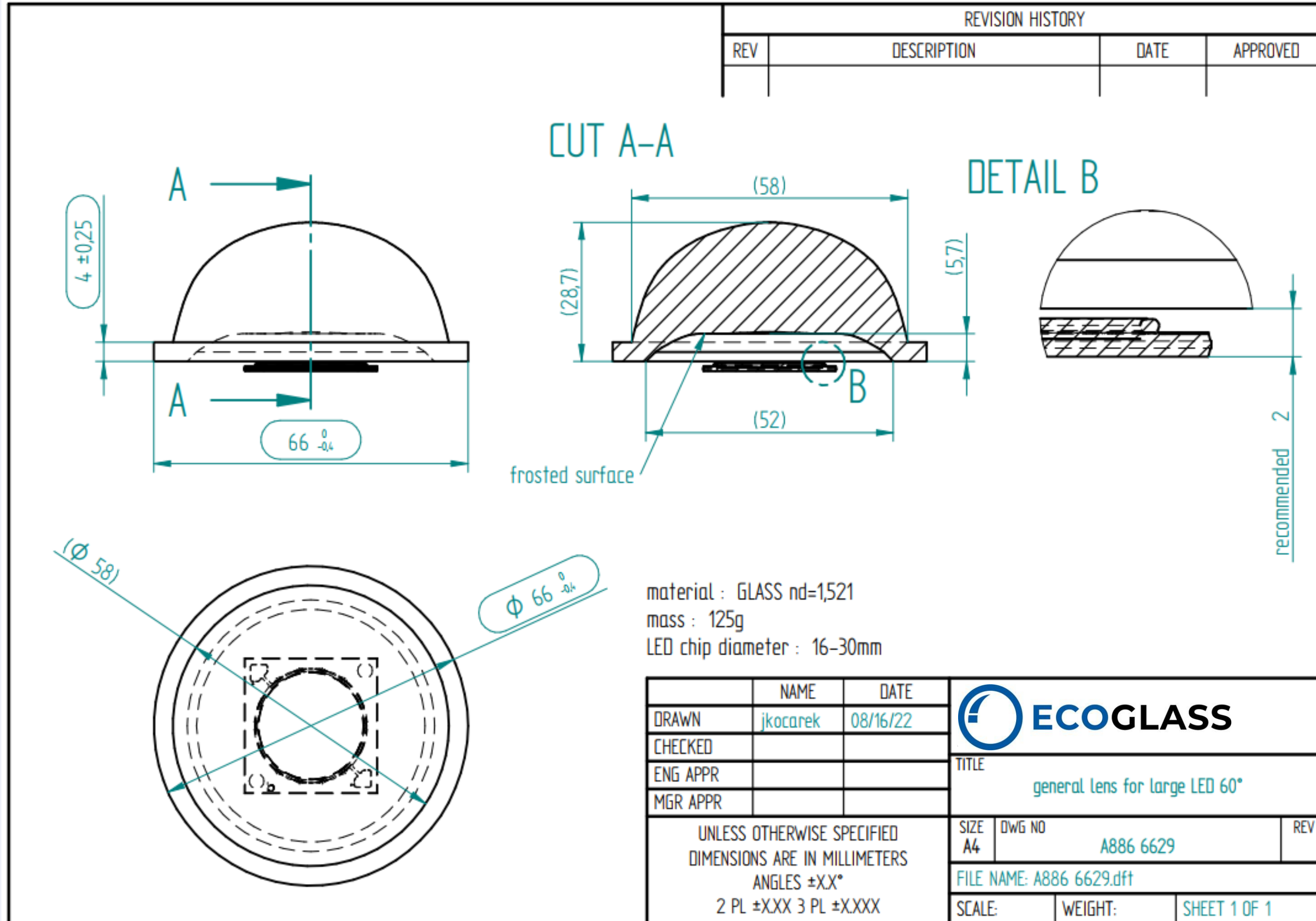

A886 6629 – simulation results

- Polar Candela Distribution Plot

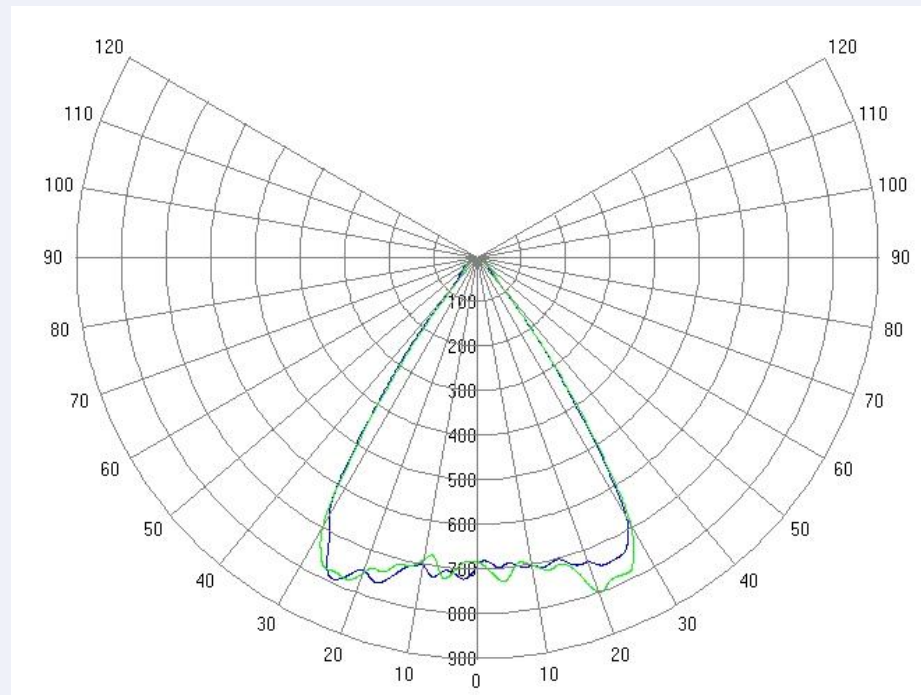

- Rectangular Candela Distribution Plot

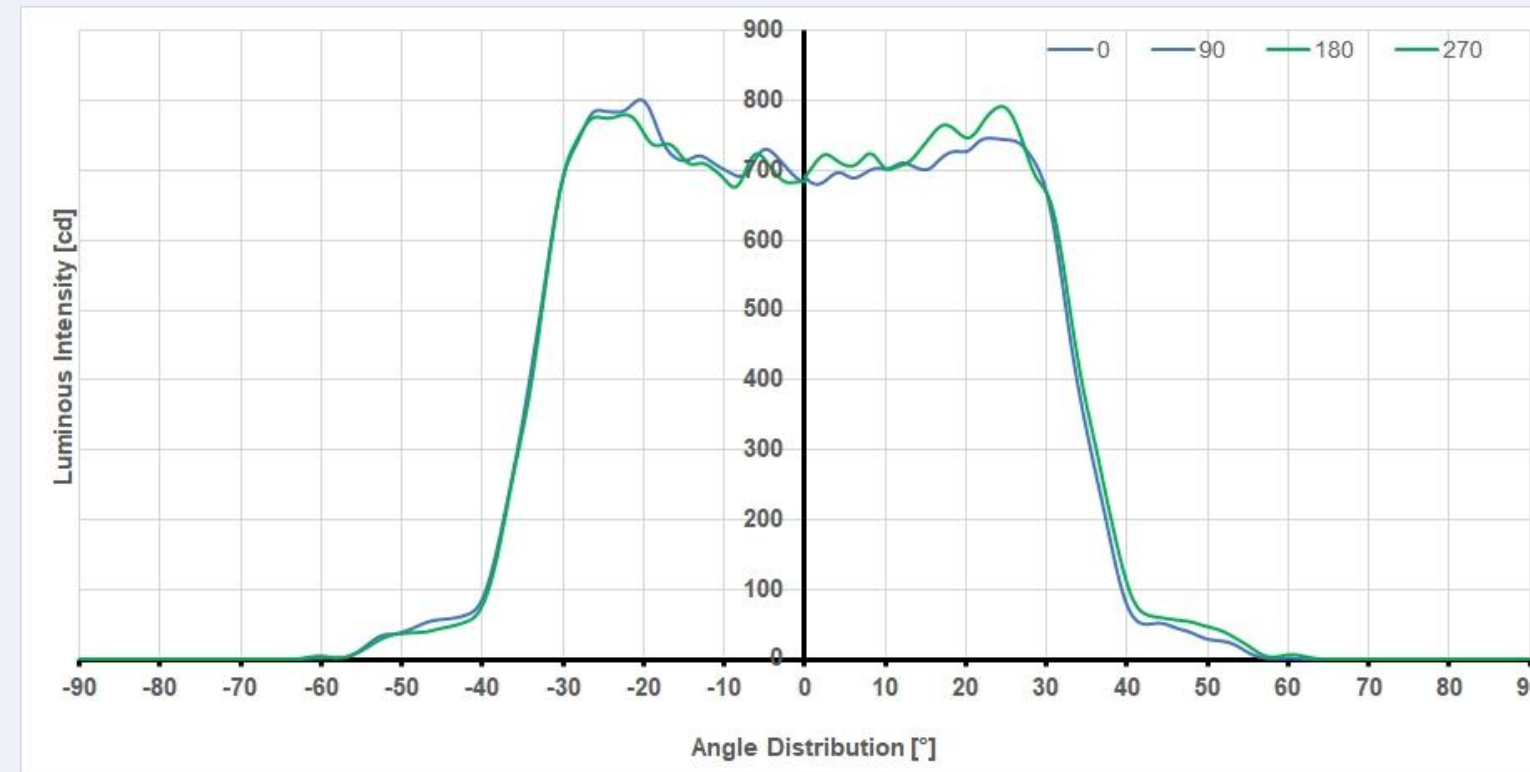

- Projection wall 5x5 m at 1m

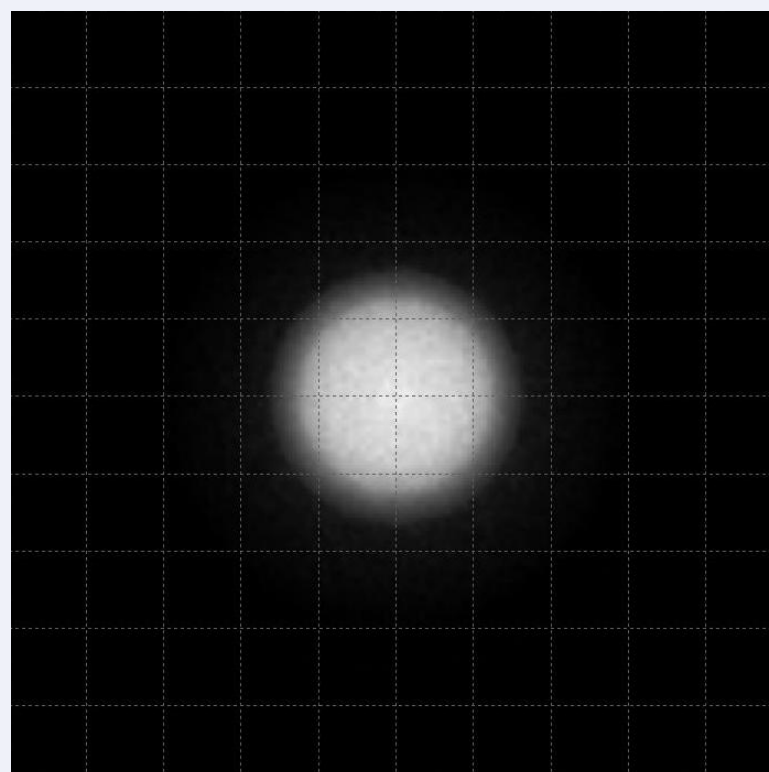

LED used for simulation	CXA2530
Luminous flux of LED [lm]	3600
Efficiency [%]*	90
FWHM Co [°]	60
FWHM C90 [°]	60

* The ratio between luminous flux on the projection wall (5x5 m at 1 m) and luminous flux of LED

A892 6624

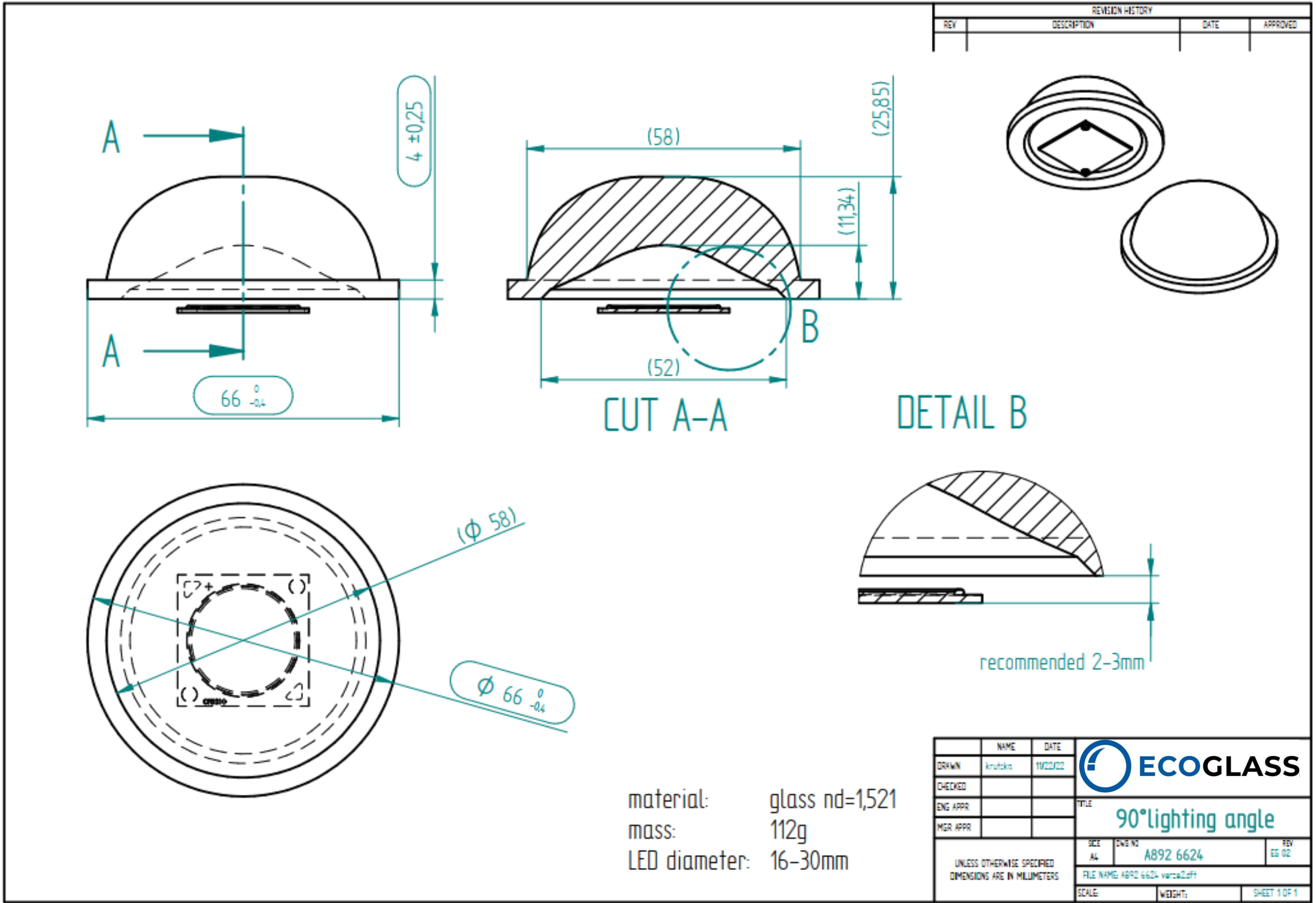

A892 6624- simulation results

- Polar Candela Distribution Plot

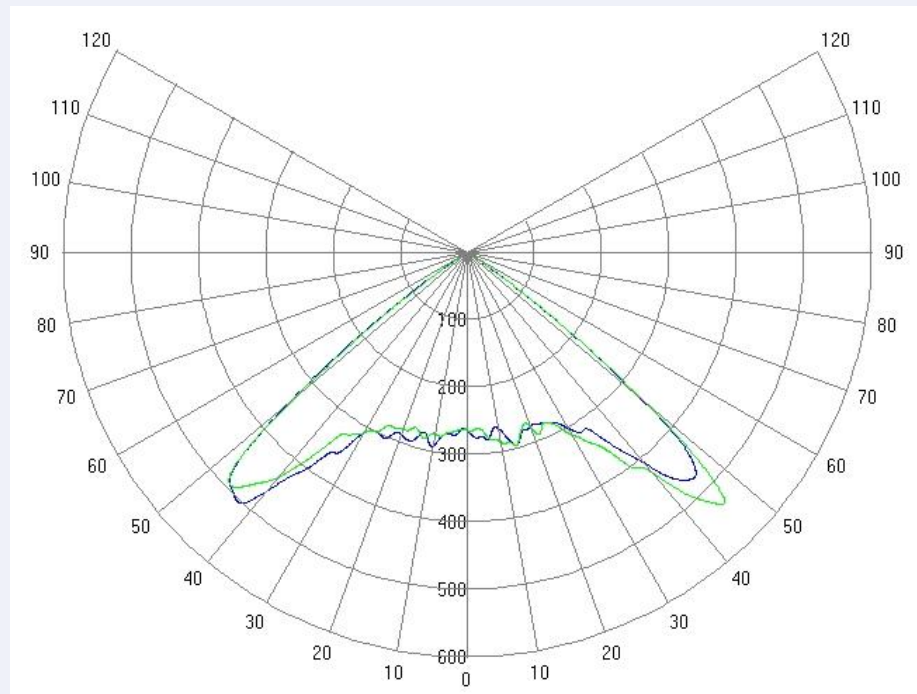

- Rectangular Candela Distribution Plot

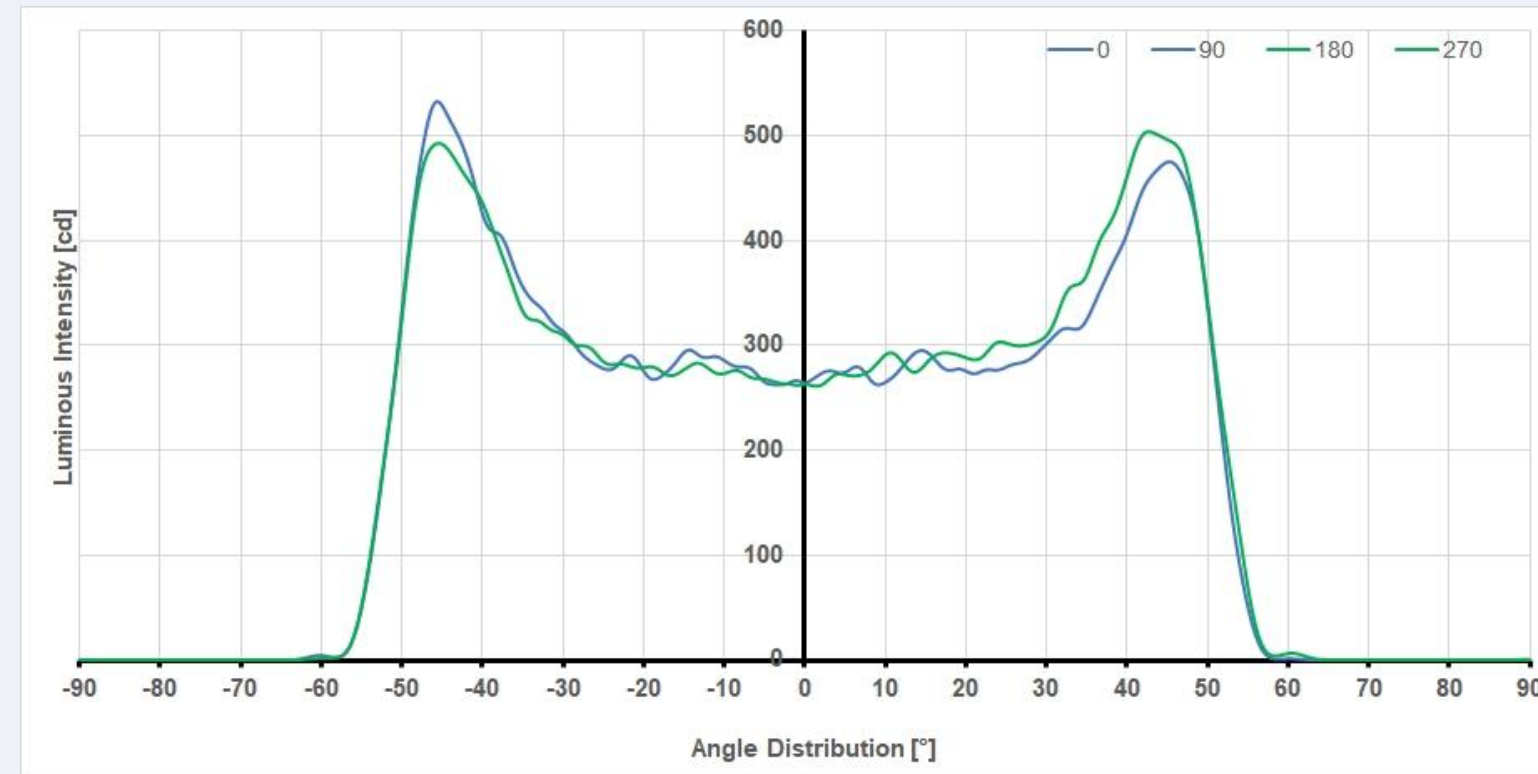

- Projection wall 5x5 m at 1m

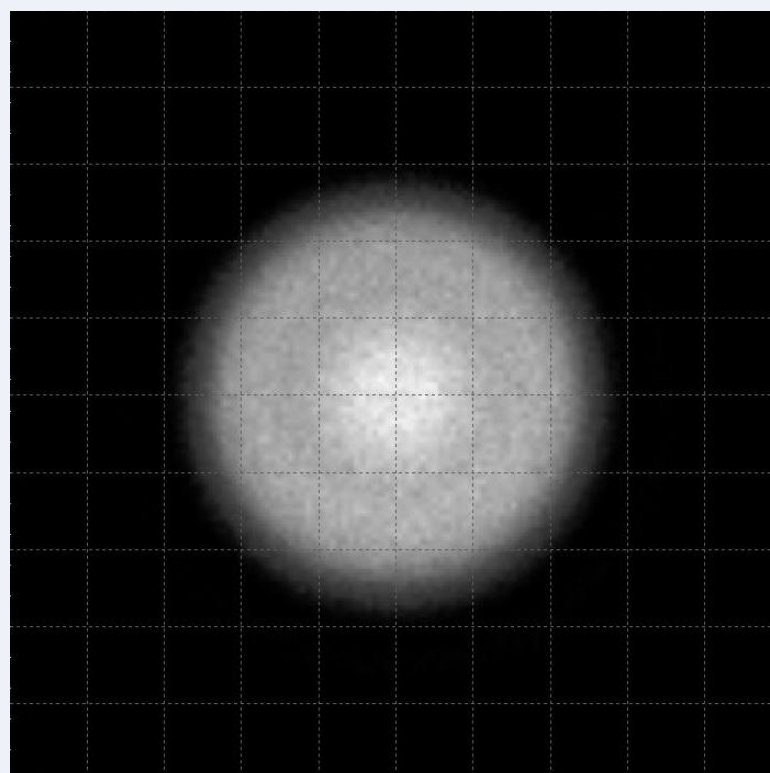

LED used for simulation	CXA2530
Luminous flux of LED [lm]	3600
Efficiency [%]*	90
FWHM Co [°]	90
FWHM C90 [°]	90

* The ratio between luminous flux on the projection wall (5x5 m at 1m) and luminous flux of LED

A893 6624

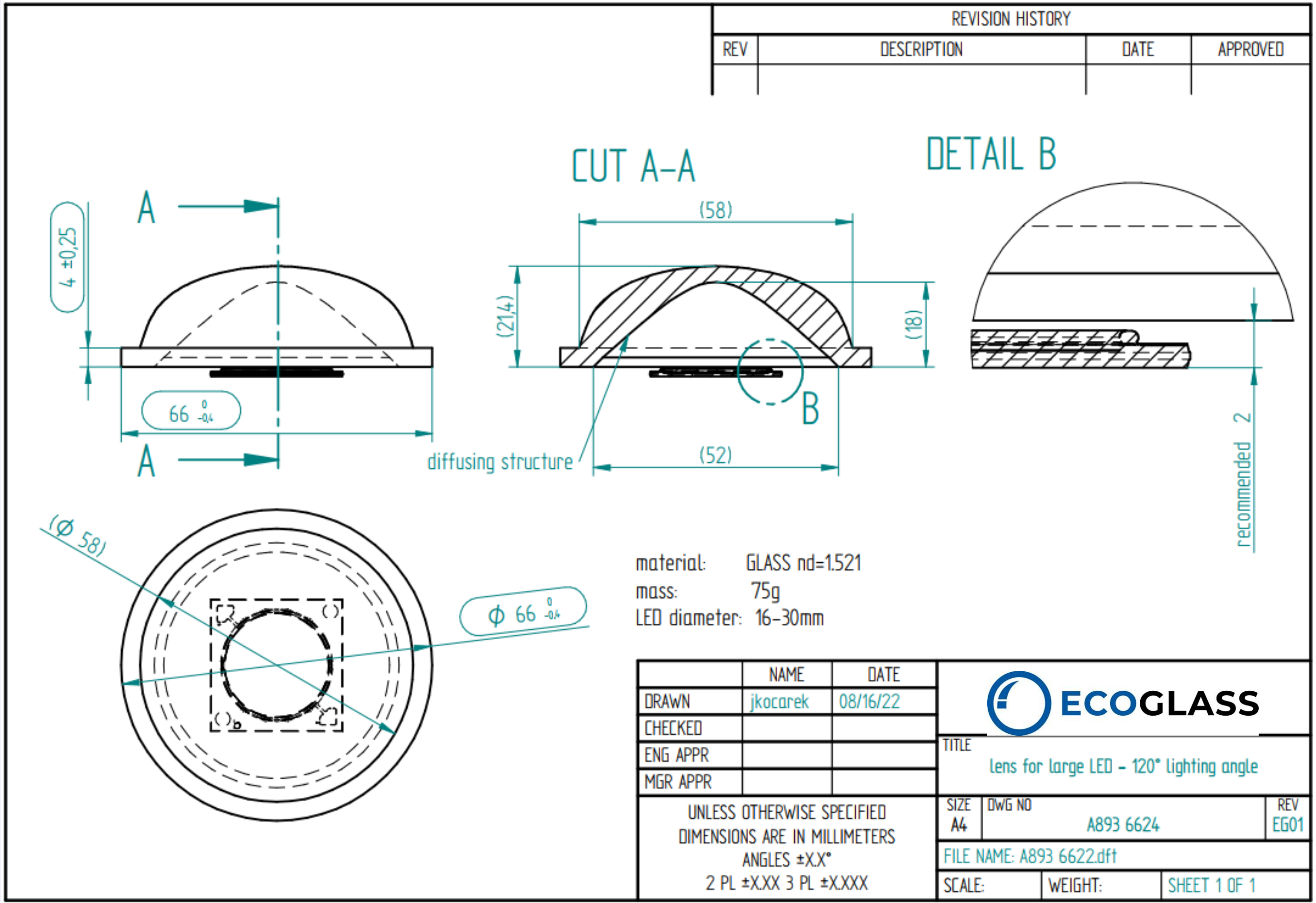

A893 6624- simulation results

- Polar Candela Distribution Plot

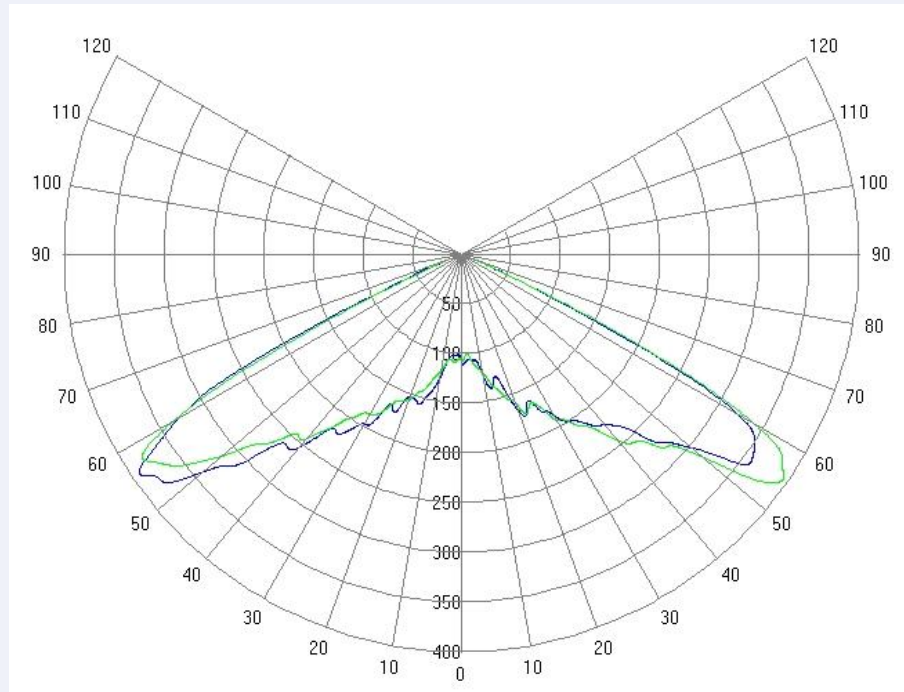

- Rectangular Candela Distribution Plot

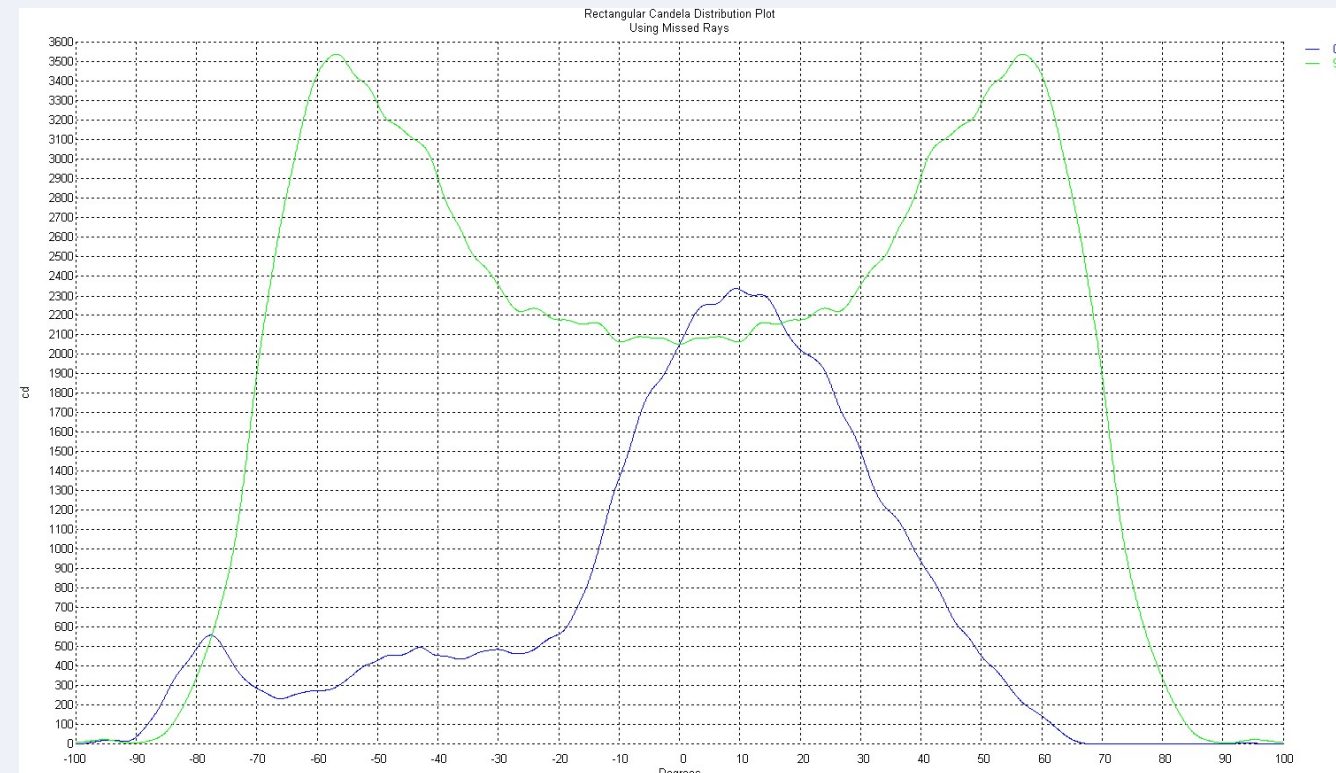

- Projection wall 5x5 m at 1m

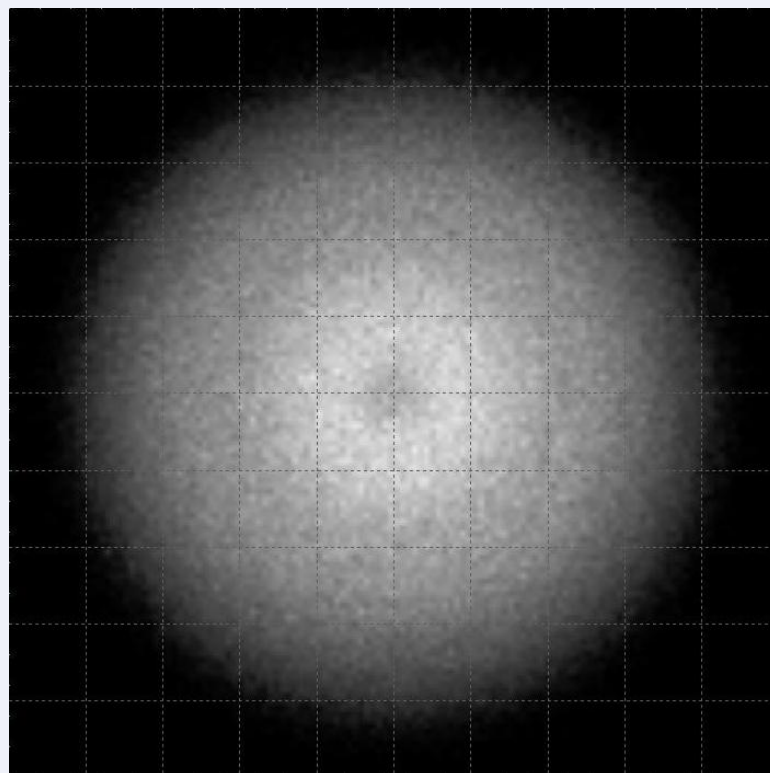

LED used for simulation	CXA2530
Luminous flux of LED [lm]	3600
Efficiency [%]*	90
FWHM Co [°]	120
FWHM C90 [°]	120

* The ratio between luminous flux on the projection wall (5x5 m at 1 m) and luminous flux of LED

A958 7625

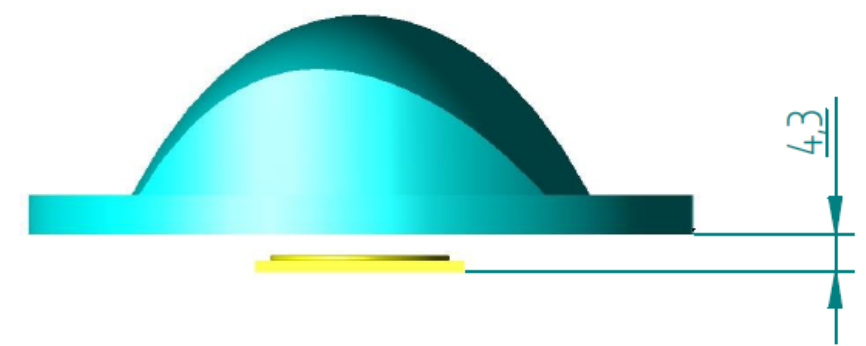
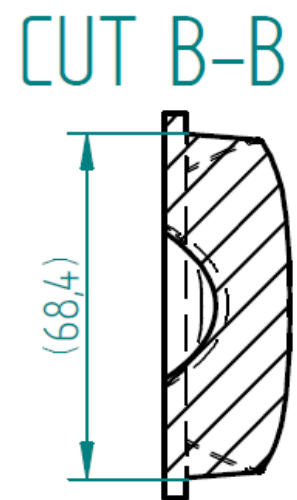
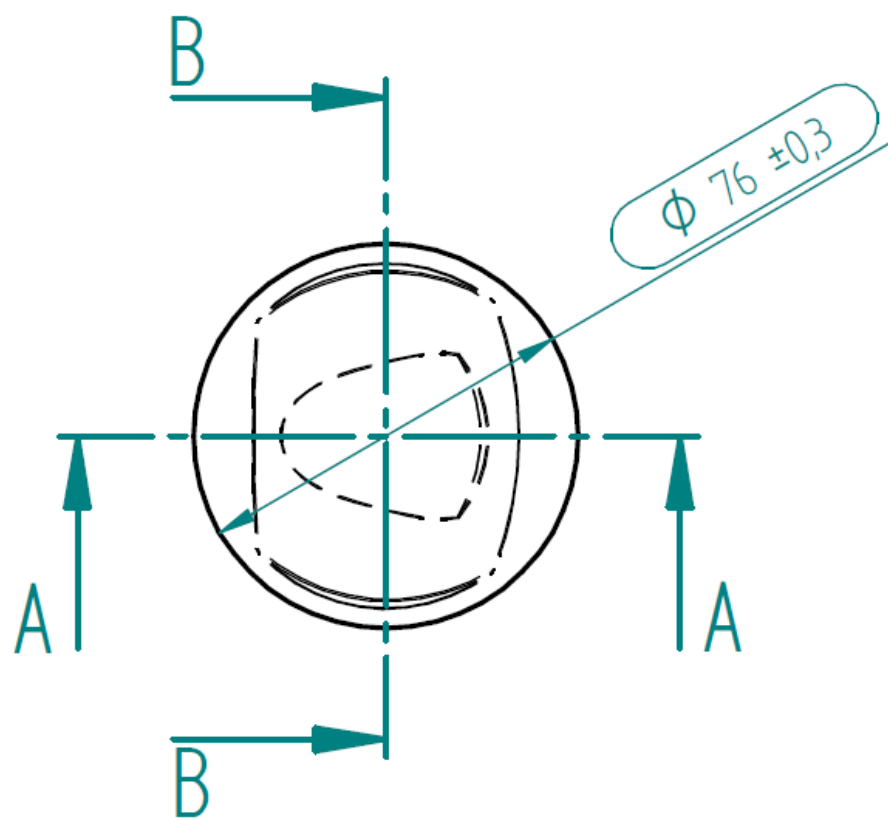
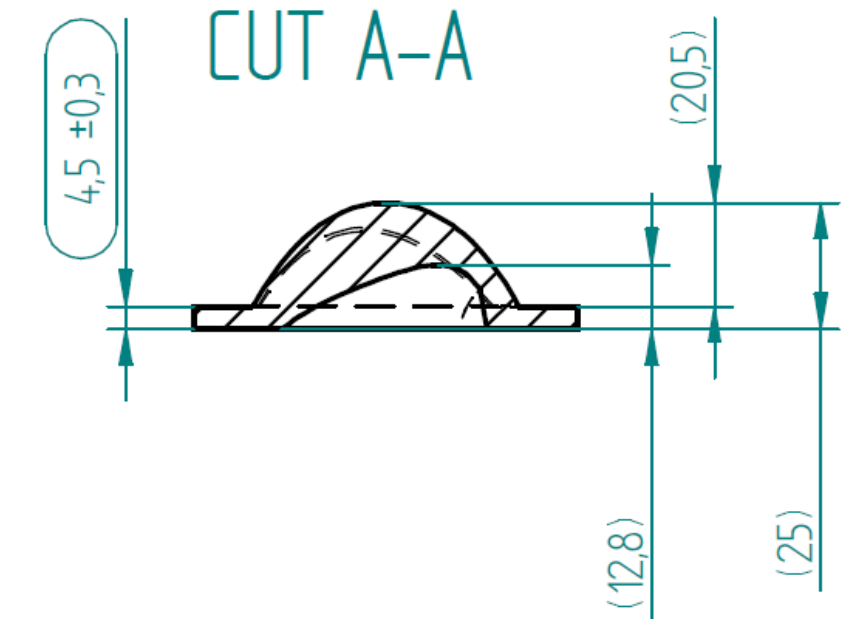

REVISION HISTORY			
REV	DESCRIPTION	DATE	APPROVED

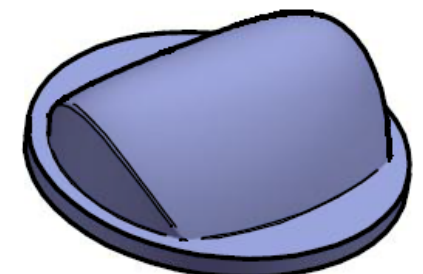
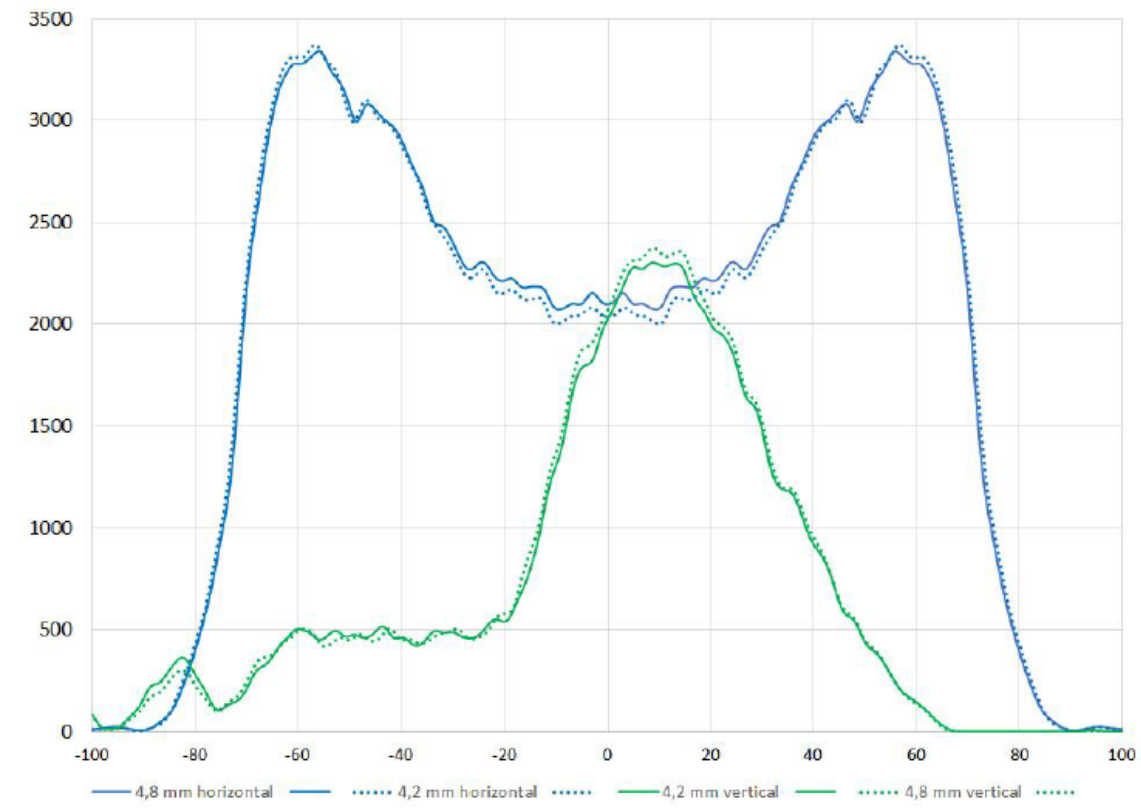

material : GLASS nd=1,520
mass : 145g

NAME	DATE		TITLE	
DRAWN	06/11/25			street lens 140°x 50°
CHECKED				
ENG APPR				
MGR APPR				
UNLESS OTHERWISE SPECIFIED DIMENSIONS ARE IN MILLIMETERS		SIZE	REV	
		A4	A958 7625	
		FILE NAME: A958 7625.dft		
		SCALE:	WEIGHT:	
		SHEET 1 OF 1		

A958 7625 – simulation results

- Polar Candela Distribution Plot

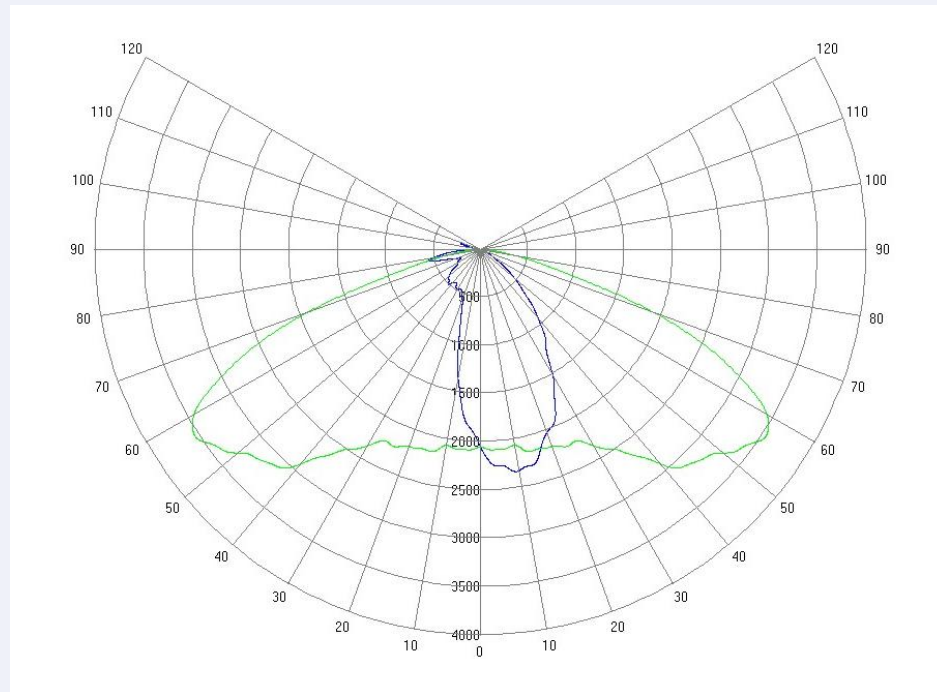

- Rectangular Candela Distribution Plot

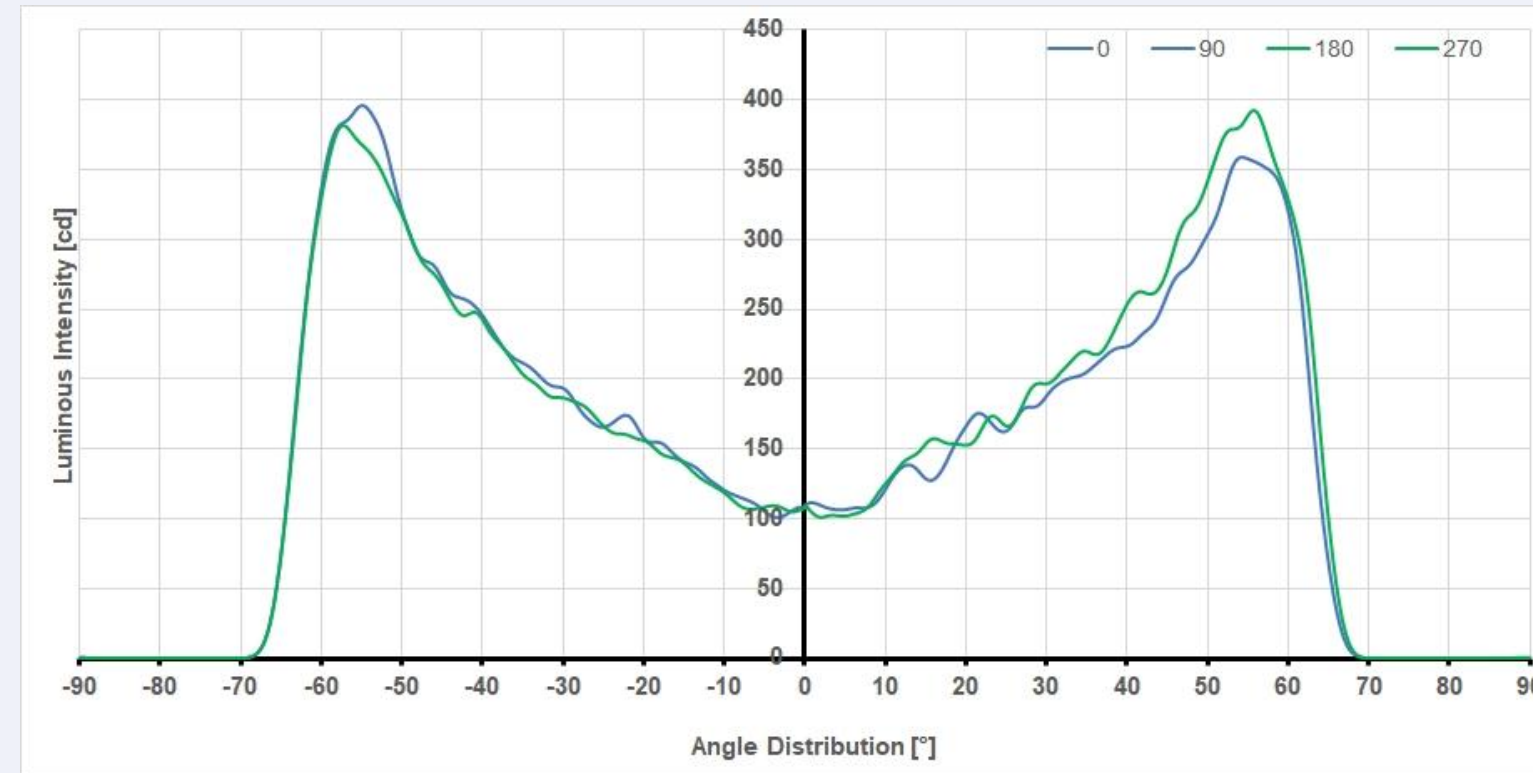

- Projection wall 80x80 m at 10m

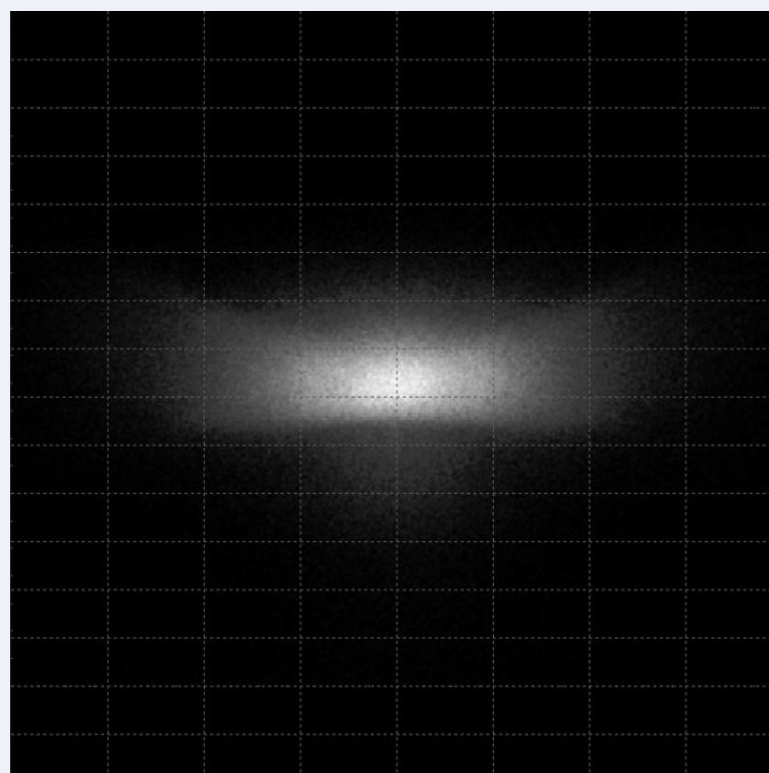

LED used for simulation	CXA2530
Luminous flux of LED [lm]	6 300
Efficiency [%]*	85
FWHM Co [°]	145
FWHM C90 [°]	45

* The ratio between luminous flux on the projection wall (5x5 m at 1 m) and luminous flux of LED

ECOGLOSS Fresnel Lenses				
ECOGLOSS code	Lens type	BFL (mm)	Diameter (mm)	Thickness (mm)
<u>A968 5206</u>	Fresnel	18,6	52	6
<u>A969 7106</u>	Fresnel	41,5	71	6

A968 5106

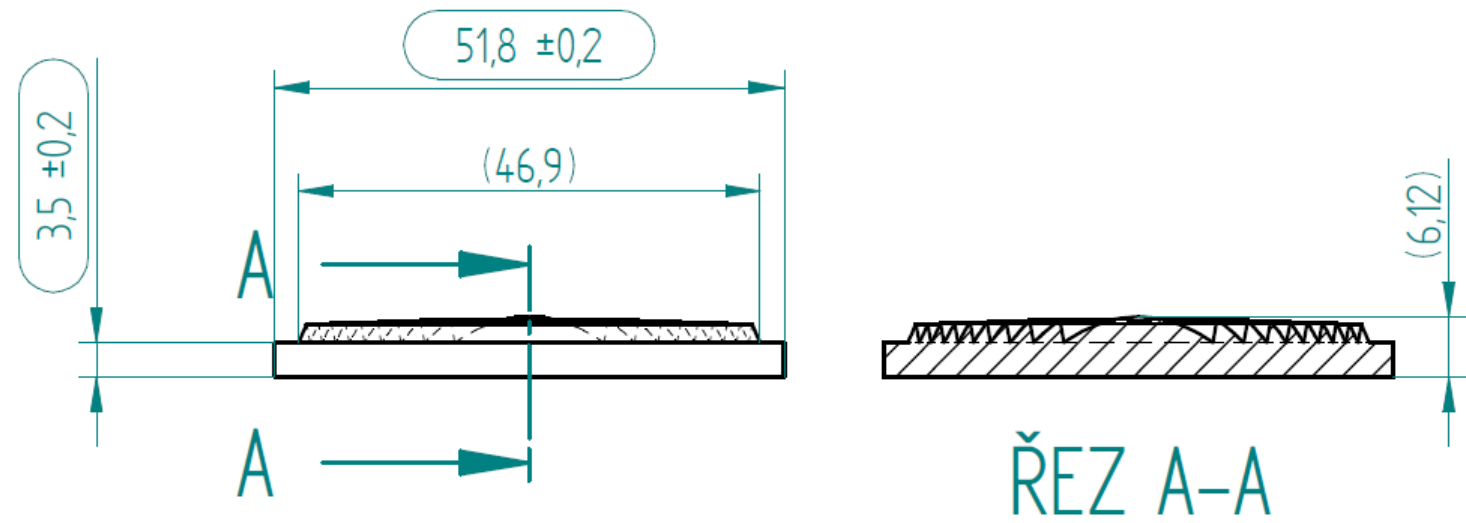

ŘEZ A-A

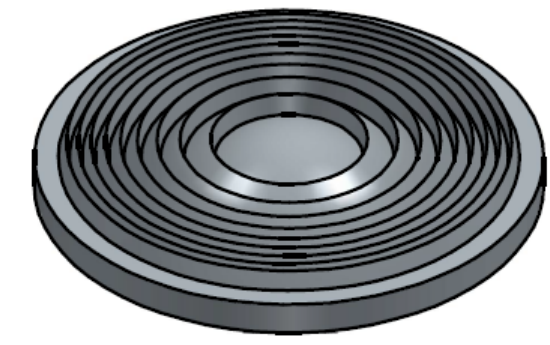
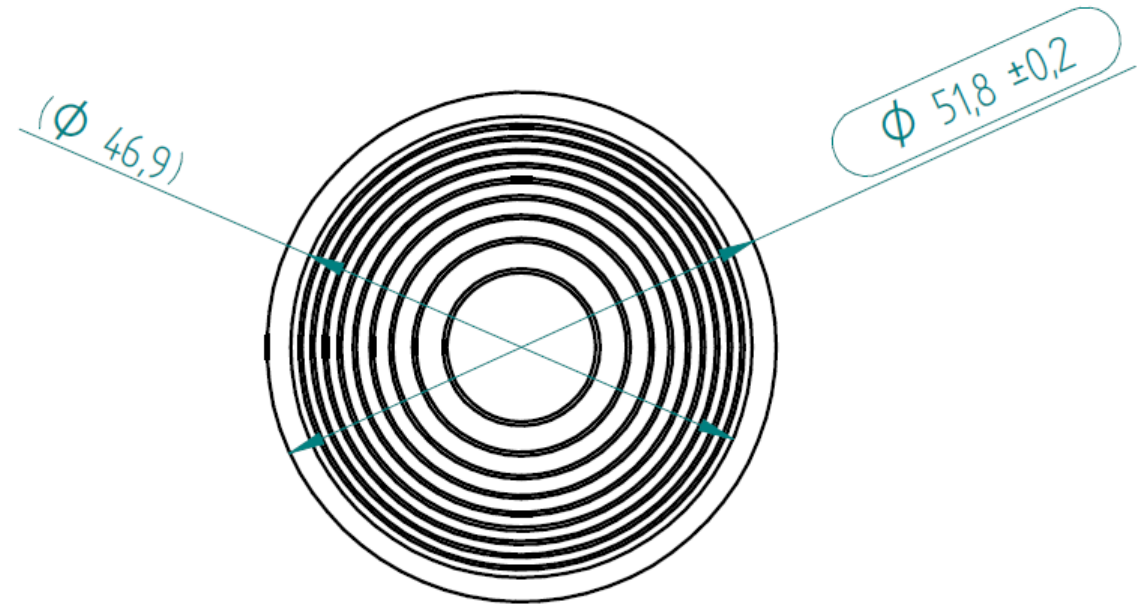
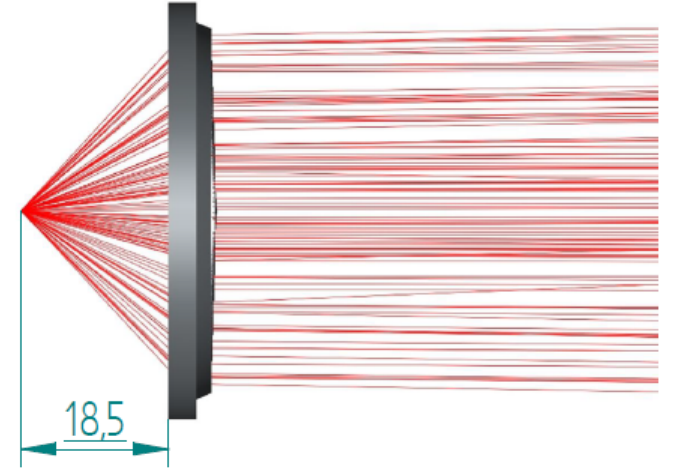

material : GLASS nd=1,520

REVISION HISTORY			
REV	DESCRIPTION	DATE	APPROVED

NAME	DATE		
DRAWN	jkocarek	09/09/25	TITLE
CHECKED			Fresnel lens
ENG APPR			
MGR APPR			
UNLESS OTHERWISE SPECIFIED DIMENSIONS ARE IN MILLIMETERS		SIZE	REV
		A4	A968 5216
		FILE NAME: A968 5216.dft	
SCALE:	WEIGHT:	SHEET 1 OF 1	

Ag68 5106– simulation results

- Polar Candela Distribution Plot

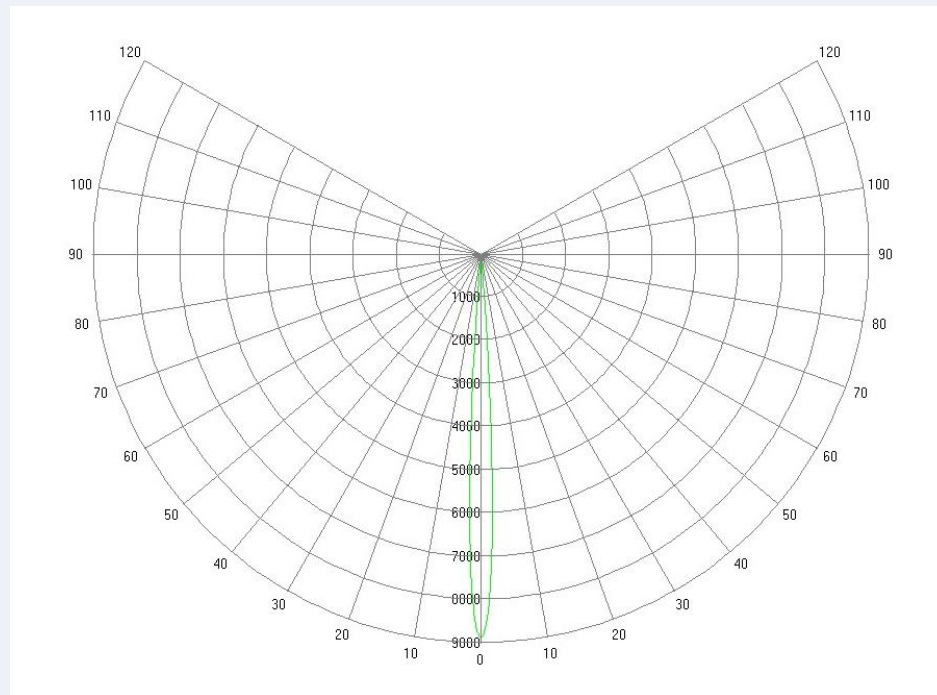

- Rectangular Candela Distribution Plot

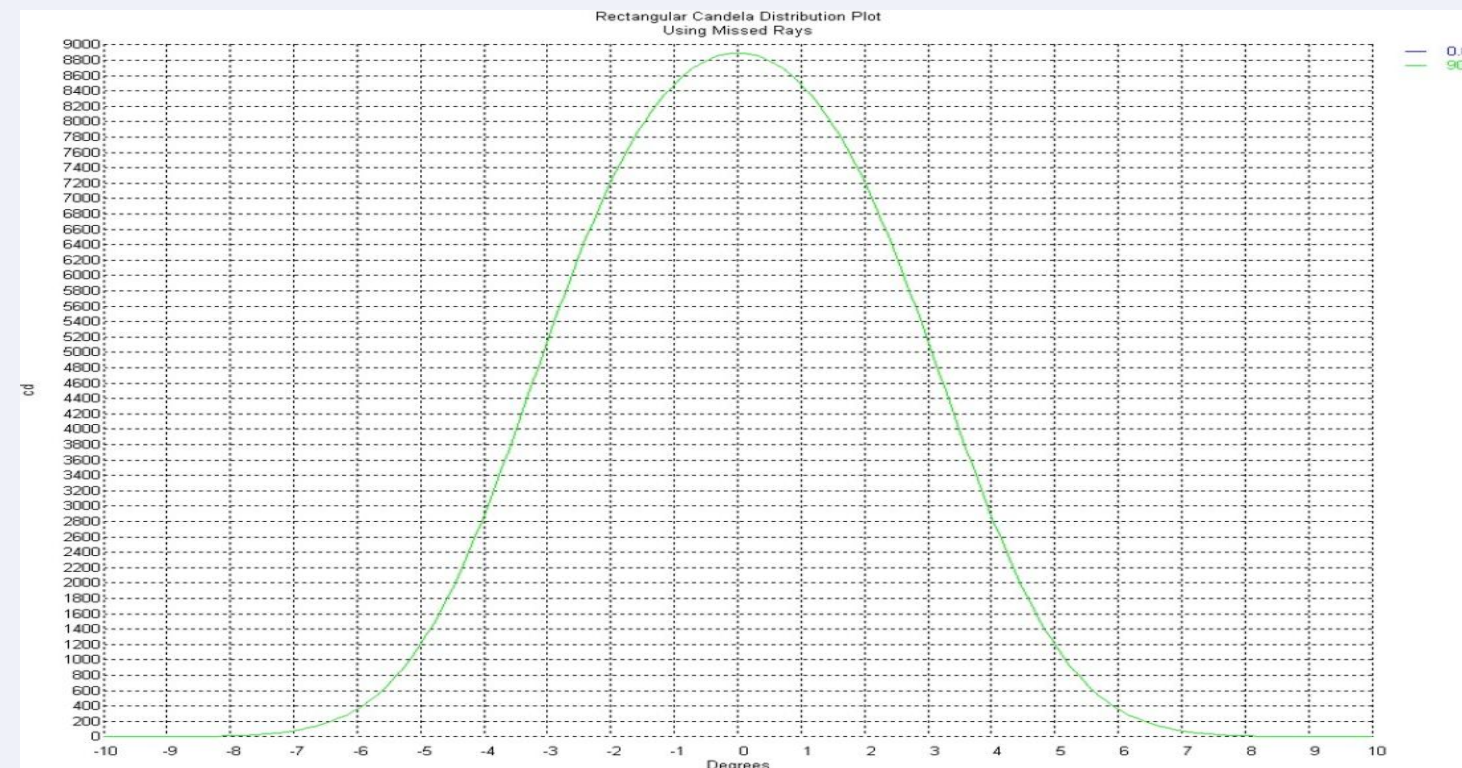

- Projection wall 3x3 m at 10m

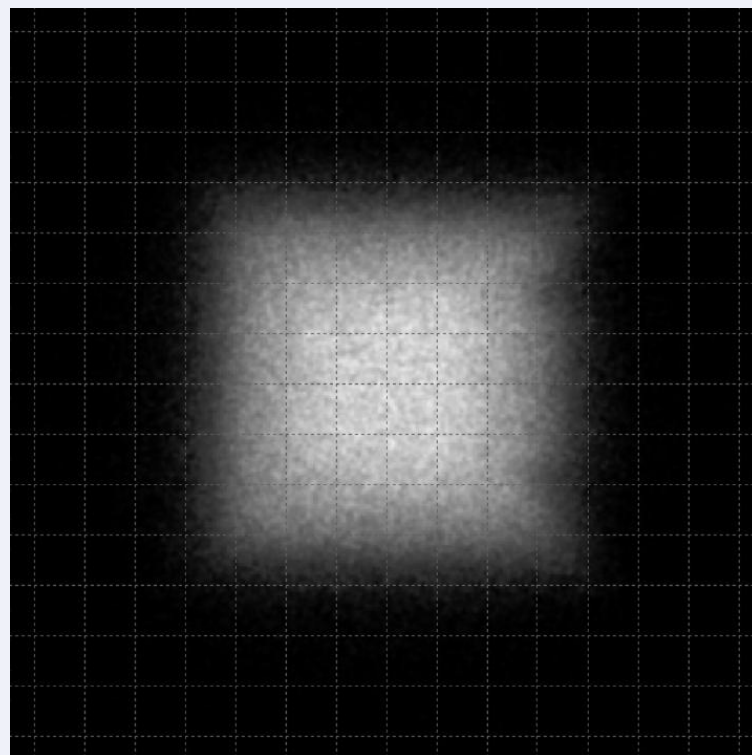

LED used for simulation	Cree XM-L2
Luminous flux of LED [lm]	2 351
Efficiency [%]*	52
FWHM Co [°]	7
FWHM C90 [°]	7

* The ratio between luminous flux on the projection wall (5x5 m at 1 m) and luminous flux of LED

Ag69 7106

REVISION HISTORY			
REV	DESCRIPTION	DATE	APPROVED

71 ± 0,2
64,83

ŘEZ A-A

4 ± 0,2 (6,15)

415

Φ 71 ± 0,2
(Φ 64,8)

material : GLASS nd=1,520

	NAME	DATE		
DRAWN	jkocarek	09/15/25	TITLE	
CHECKED				
ENG APPR				
MGR APPR				
UNLESS OTHERWISE SPECIFIED DIMENSIONS ARE IN MILLIMETERS			SIZE A4	REV
			FILE NAME: A969 7106.dft	
SCALE		WEIGHT	SHEET 1 OF 1	

Ag69 7106– simulation results

- Polar Candela Distribution Plot

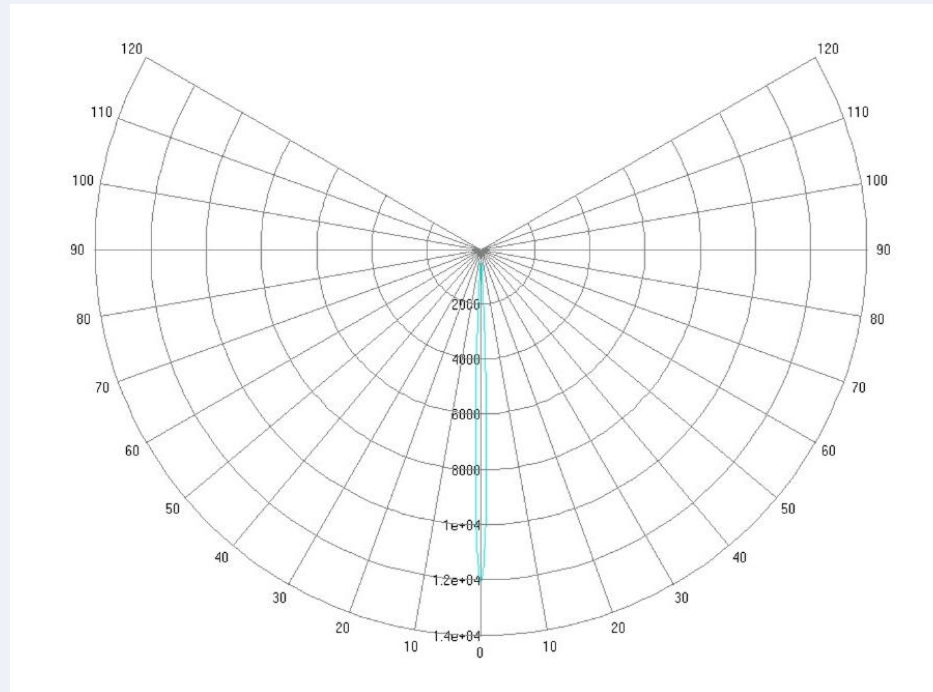

- Rectangular Candela Distribution Plot

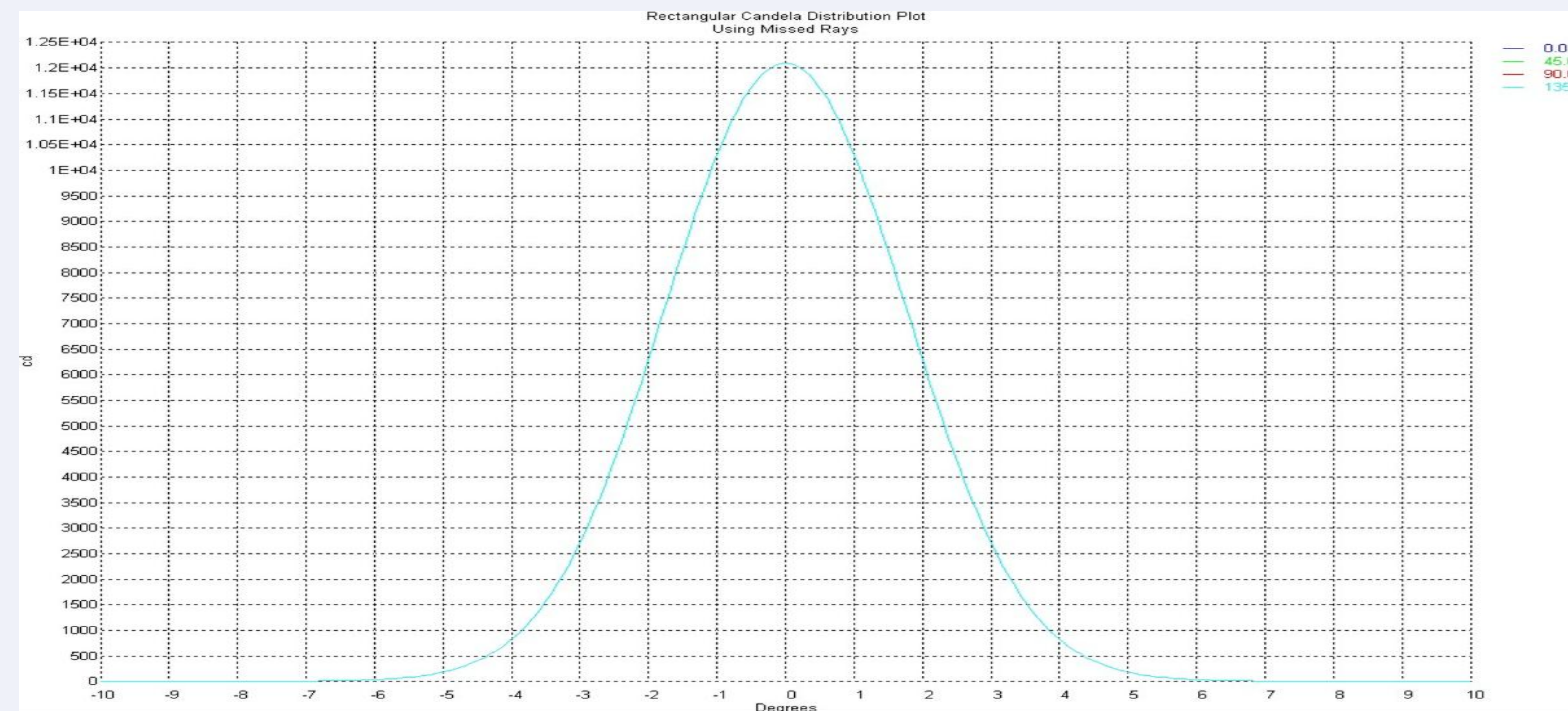

- Projection wall 3x3 m at 10m

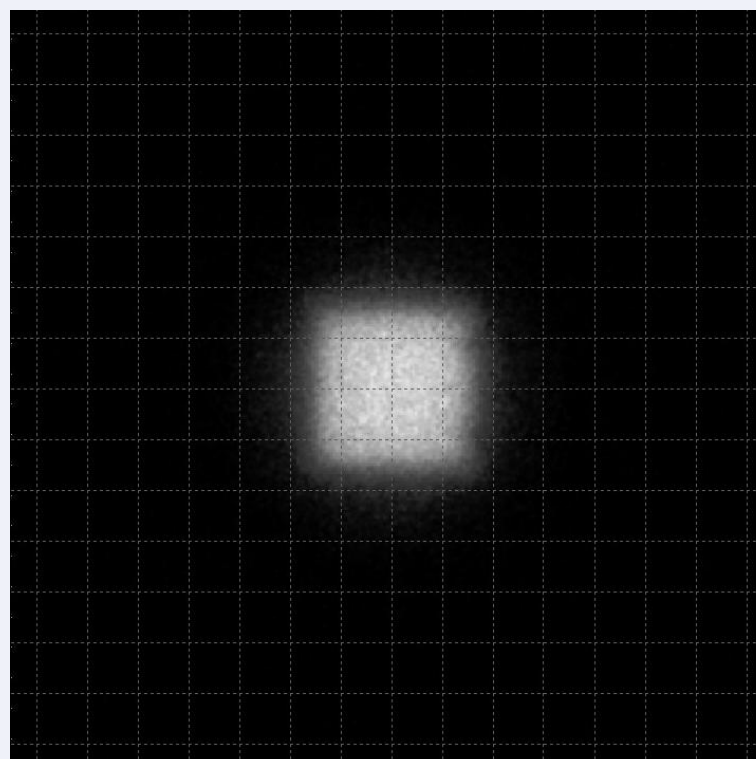

LED used for simulation	Cree XM-L2
Luminous flux of LED [lm]	2 351
Efficiency [%]*	30
FWHM Co [°]	4
FWHM C90 [°]	4

* The ratio between luminous flux on the projection wall (5x5 m at 1 m) and luminous flux of LED



ecoglass-optic.com

© ECOGLASS, a.s. | Arbesova 66a | 466 04 Jablonec nad Nisou | +420 483 316 820 | info@ecoglass.cz | e-shop@ecoglass.cz

